

STIHL



**Skæreværktøjer, reservedele og
tilbehør**

2019



Skæreværktøjer

Trimmerhoveder	4
Græsknive	5
Kratkniv	6
Rundsavsklinger	6
Snittekniv	7
Sikkerhedshenvisninger	7

Tilordningstabel

Skæreværktøjer - trimmere	8
---------------------------------	---

Skæreværktøj - påbygning

FE 55	17
FR 85, 85 T + FS-KM, 106, 108	18
FR 85, 130 T + FSB-KM (a)	21
FR 130 T, 131 T + FS-KM (a), FR 410 (b), 460 (b)	22
FR 130 T + FS-KM (a), FR 220, 350, 410 (b), 450, 460 (b), 480	24
FR 235	28
FS 25-4, 44, 55 (a), 55 T + FS-KM	29
FS 36, 40 (a), 72, 75	32
FS 38, 40 (a)	33
FS 45, 50 (a)	34
FS 48, 50 (a), 51, 52, 56 (b), 62	35
FS 55 (a), 56 (b), 70	36
FS 65, 80 (a), 90 (a)	38
FS 80 (a), 85 (a)	40
FS 80 (a), 85 (b), 85 T + FS-KM, 87, 90 (c), 100 (d), 110	43
FS 66, 74, 76, 81, 86 (a), 88, 106, 108	47
FS 86 (a), 96	50
FS 89, 91, 111 (a), 131	53
FS 94 (a)	56
FS 94	57
FS 100 RX	59
FS 111 RX	60
FS 120, 250 (a)	61
FS 235	64
FS 235 R	66
FS 120, 130, 200 (a), 240, 250, 260 R (b), 460 R (c)	67
FS 240, 240 R, 260 R (a)	71
FS 150, 151, 200 (a), 202, 353, 410 (b)	74
FS 160, 220, 280, 290, 300, 310, 350, 380, 400, 450, 480	76
FS 160, 180, 220, 280, 300, 350, 400, 450	81
FS 260 (a), 311, 360 (b), 410 (b, c), 460 (a, c), 490 (c)	85
FS 360 (a), 420	89
FS 410 K (a, b), 460 K (b, c), 490 K (b)	91
FS 500, 550	93
FS 510, 560	98
FT 250	101
FSA 45	102
FSA 56, 57	103
FSA 65, 85	104
FSA 90	105
FSA 130	106
FSA 130 R	109
KMA 130 R + FS-KM (a)	111
FSE 31, 41	113
FSE 52	114
FSE 60, 71, 81	115
FSE 65	116

KA 85, 120, 250, + FS (a).....	117
KA 85, 120, 250, KR 85, + FS (a).....	120
KM 55, 56 + FS-KM (a)	123
KM 55, 56 + FS-KM (a)	125
KM 55, 56, 85, 90, 91, 100, 110, 111 + FSB-KM (a)	128
KM 55, 56, 85, 90, 91, 100, 110, 111 + FSB-KM (a)	129
KM 85, 90, 91, 94, 100, 110, 111, 130, 131, + FS-KM (a)	130
KM 85, 90, 94, 100, 110, 130, + FS-KM (a)	133
MM 55, 56 + FS-MM.....	137

Reserve dele og tilbehør

Polymatic 40-2.....	138
TrimCut 30-2.....	139
TrimCut 31-2.....	140
TrimCut 40-2.....	142
TrimCut 41-2.....	143
TrimCut 50-2.....	144
TrimCut 51-2.....	145
AutoCut 2-2	147
AutoCut C 4-2.....	147
AutoCut 5-2	148
AutoCut C 5-2.....	148
AutoCut C 6-2.....	149
AutoCut 11-2	150
AutoCut 21-2	151
AutoCut 25-2	152
AutoCut C 25-2.....	153
AutoCut C 26-2.....	154
AutoCut 30-2	155
AutoCut 36-2	156
AutoCut 36-2	157
AutoCut 40-2	158
AutoCut 46-2	159
AutoCut 46-2	160
AutoCut 40-4	161
AutoCut 56-2	162
AutoCut 56-2	163
SuperCut 20-2.....	164
SuperCut 40-2	165
PolyCut 2-2.....	166
PolyCut 5-3.....	167
PolyCut 6-3.....	167
PolyCut 7-3.....	168
PolyCut 20-3.....	169
PolyCut 27-3.....	170
PolyCut 40-3.....	171
PolyCut 41-3.....	171
PolyCut 47-3.....	172
DuroCut 5-2.....	173
DuroCut 20-2.....	174
DuroCut 40-4.....	175
FixCut 5-2	176
FixCut 25-2.....	177
FixCut 31-2.....	178

Runde trimmertråde.....	179
Runde trimmertråde, støjsvage	180
Kvadratiske trimmertråde	181
Femkantede trimmertråde	182
Runde trimmertråde, tilpasset længde	183
Femkantede trimmertråde, afkortet	183
Fortandet trimmertråd, tilpasset længde.....	184
Trimmertråde CF3 Pro.....	184
Afbalanceringsapparat, slibevejledninger og slibeværktøjer	185
Transportbeskyttelse til skæreværktøj af metal	189

STIHL KombiSystem

STIHL KombiVærktøjer	192
KombiVærktøjer til redskaber med deleligt skaft	194





STIHL påbygningsværktøj

Påbygningsværktøj til STIHL-redskaber.....	196
--	-----

STIHL Multisystem

MultiVærktøj til STIHL MM 55, 56.....	200
---------------------------------------	-----

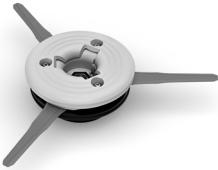
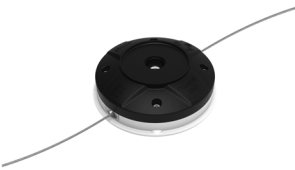
Trimmerhoveder

	<p>STIHL SuperCut</p> <p>Trimmertråden efterjusteres automatisk. Til trimning af græskanter, mindre græsarealer og omkring hindringer.</p>
	<p>STIHL AutoCut</p> <p>Trimmertråden efterjusteres semiautomatisk ved tryk på trimmerhovedet. Til slåning af græskanter, mindre græsarealer og omkring hindringer.</p>
	<p>STIHL TrimCut</p> <p>Trimmertråden efterjusteres manuelt. Til slåning af græskanter, mindre og op til mellemstore græsarealer og omkring hindringer.</p>
	<p>STIHL PolyCut</p> <p>Høj græsslåningseffekt takket være plastknive. Til græsslåning af ukrudt omkring hindringer og på små græsarealer. I store udførelser kan der i stedet for plastknive anvendes trimmertråde til at slå græs med.</p>
	<p>STIHL DuroCut</p> <p>Til anvendelse af manuelt tilpassede trimmertråde. I hver DuroCut-udførelse kan der anvendes trimmertråde med forskellige tykkelse og type. Til slåning af lavt græs og omkring faste genstande.</p>
	<p>STIHL FixCut</p> <p>Til anvendelse af manuelt tilpassede trimmertråde. Til slåning af græskanter, mindre græsarealer og omkring hindringer.</p>

Græsknive

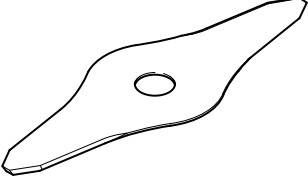
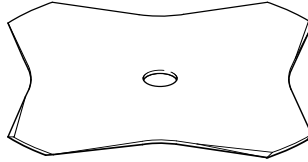
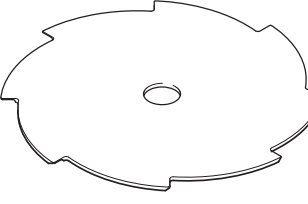
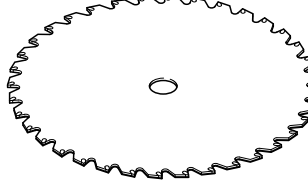
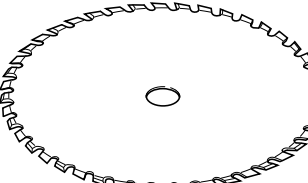
 <p>681KT1101 KN</p>	<p>Græskniv, 2-vinget</p> <p>Robust, høj slåningseffekt, især til ukrudt og kraftigt skæremateriale, særdeles god accelerationsreaktion.</p>
 <p>681KT759 KN</p>	<p>Græskniv, 4-vinget</p> <p>Robust, til slåning af arealer, høj slåningseffekt i tæt skæremateriale som græs og ukrudt.</p>
 <p>681KT406 KN</p>	<p>Græskniv, 8 tænder</p> <p>Robust, til slåning af arealer også ved lav skæremodstand, høj slåningseffekt i let skæremateriale som tørt græs, bregner, brændenælder og siv.</p>
 <p>681KT516 KN</p>	<p>Græskniv Special</p> <p>Har tænder af hårdmetal og er især egnet til hårde anvendelsesbetingelser med lang levetid og anvendelsesvarighed. Til slåning af kraftigt græs.</p>
 <p>681KT873 KN</p>	<p>Græskniv, lav udslyngning</p> <p>Anvendelse af denne anbefales især, når omgivelserne kan udsættes for fare ved udslyngede fremmedlegemer. Til slåning af græs.</p>

Kratkniv

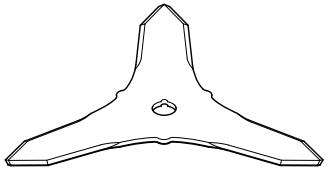
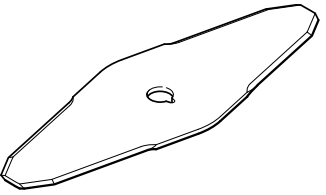
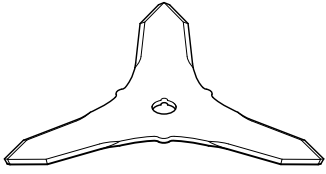
 <p style="writing-mode: vertical-rl; transform: rotate(180deg); font-size: small;">681K1405 KN</p>	<p>Kratkniv, 3-vinget</p> <p>Til meget kraftig skæremateriale og til rydning af krat, buskadser og buske samt til slåning af trægt og sammenfiltret græs. Kan anvendes med special snitteknivsbeskyttelse til snitning.</p>
 <p style="writing-mode: vertical-rl; transform: rotate(180deg); font-size: small;">681K1415 KN</p>	<p>Kratkniv Special, 2-vinget</p> <p>Fremstillet af kraftigt, slidstærkt specialstål: høj skæreydelse og snitkvalitet i kraftigt skæremateriale. Ved anvendelse som græskniv opnås en høj arealydelse.</p>
 <p style="writing-mode: vertical-rl; transform: rotate(180deg); font-size: small;">681K1405 KN</p>	<p>Kratkniv Special, 3-vinget</p> <p>Anvendelse som "standard"-kratkniv, dog af slidstærkt specialstål: med længere levetid til særlig hårde anvendelser.</p>

Rundsavsklinger

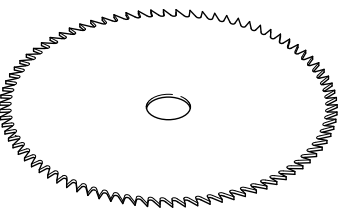
 <p style="writing-mode: vertical-rl; transform: rotate(180deg); font-size: small;">681K1408 KN</p>	<p>Rundsavsklinge, mejseltandet</p> <p>Samme anvendelsesområder som spidstandet, dog med et roligere og blødere snit, reduceret tilbageslag, meget let at slibe, god skæreeffekt.</p>
 <p style="writing-mode: vertical-rl; transform: rotate(180deg); font-size: small;">681K1407 KN</p>	<p>Rundsavsklinge, spidstandet</p> <p>Til skæring af knoldede buske, krat, undervækst, træagtigt buskads, hække og tynde træstammer, særlig god skæreeffekt.</p>

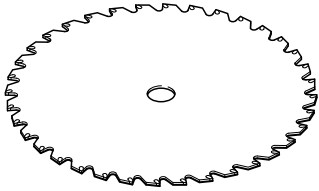
 681KT335 KN	<p>Rundsavsklinge, hårdmetal</p> <p>Særlig god skæreeffekt; også eget til klipping af hæk.</p>
---	---

Snittekniv

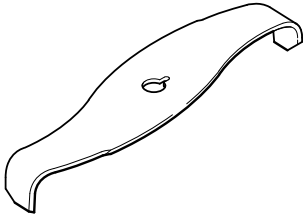





 681KT382 KN	<p>Snittekniv, 2-vinget</p> <p>Fremstillet af kraftigt, slidstærkt specialstål: Som følge af den særlige knivform, og sammen med snittebeskyttelsen, er den perfekt til snitning, rydning og fjernelse af kraftigt skæremateriale som vildskud, hække osv.</p>
---	---

Sikkerhedshenvisninger







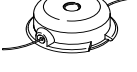

Der kræves transportbeskyttelse af skæreværktøjer af metal.

Ved anvendelse af græsknive kræves der en skridtbegrænser på specialhåndtaget (bøjle).

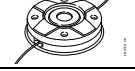
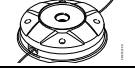

Anvendelse af rundsavsklinger er kun tilladt på redskaber med tohåndsgreb.

			FR 131 T + FS-KM, FR 220	FR 235	FR 410, 450, 460, 480	FS 38, 40 ④, 45, 50 ④	FS 55, 56 ④, 70	FS 55 R, 56 R ④, 70 R	FS 80 ⑤, 85, 89	FS 80 R ⑤, 85 R, 89 R	FS 94	FS 94 R	FS 91, 111	FS 91 R, 111 R	FS 111 RX	FS 120 R	FS 120, 250	FS 131	FS 131 R	
	SuperCut 20-2	4002 710 2162	•	•	•		•	•	•	•	•	•	•	•	•	•	•	•	•	•
	SuperCut 40-2	4003 710 2140																		
	AutoCut 2-2	4008 710 2100																		
	AutoCut C 4-2	4006 710 2121																		
	AutoCut 5-2	4006 710 2100				•														
	AutoCut C 6-2	4006 710 2126				•														
	AutoCut 11-2	4004 710 2105																		
	AutoCut 25-2	4002 710 2108	•	•	•		•	•	•	•	•	•	•	•	•	•	•	•	•	•
	AutoCut C 26-2	4002 710 2169	•	•	•		•	•	•	•	•	•	•	•	•	•	•	•	•	•
	AutoCut 36-2	4002 710 2170		•									•	•	•	•	•	•	•	•
	AutoCut 46-2	4003 710 2115																		
	AutoCut 56-2	4005 710 2107																		
	TrimCut 31-2	4002 710 2152	•		•		•	•	•	•			•	•	•	•	•	•	•	•
	TrimCut 41-2 ②	4003 710 2104																		
	TrimCut 51-2 ③	4005 710 2103																		

																					FS 160, 220, 260	
																					•	FS 235
																						FS 235 R
																					•	FS 240
																					•	FS 240 R, 260 R, 460 R
																					•	FS 250 R
																						FS 280, 290, 450, 460, 490
																						FS 311
																					•	FS 360 @ , 400, 410
																						FS 410 K, 460 K, 490 K
																						FS 510, 560
																						FSA 45
																					•	FSA 56, 57
																						FSA 65, 85
																					•	FSA 90
																					•	FSA 90 R
																					•	FSA 130
																					•	FSA 130 R
																						FSE 52
																						FSE 60, 71, 81
																					•	KM 56 R + FS-KM
																						KM 55 R, 56 R, + FSB-KM
																					•	KM 85 R, 91 R, 94 R, 111 R, + FS-KM
																						KM 85 R, 91 R, 94 R, 111 R, + FSB-KM
																					•	KM 131 + FS-KM
																					•	KM 131 R + FS-KM
																					•	KMA 130 R + FS-KM

			FR 131 T + FS-KM, FR 220																
			FR 235		FR 410, 450, 460, 480	FS 38, 40 ④, 45, 50 ④	FS 55, 56 ④, 70	FS 55 R, 56 R ④, 70 R	FS 80 ⑤, 85, 89	FS 80 R ⑤, 85 R, 89 R	FS 94	FS 94 R	FS 91, 111	FS 91 R, 111 R	FS 111 RX	FS 120 R	FS 120, 250	FS 131	FS 131 R
	FixCut 31-2	4001 710 2105	•	•	•	•	•	•	•	•	•	•	•	•	•	•	•	•	•
	PolyCut 2-2	4008 710 2102																	
	PolyCut 5-3	4004 710 2131																	
	PolyCut 7-3	4006 710 2127			•														
	PolyCut 27-3	4002 710 2176	•	•	•	•	•	•	•	•	•	•	•	•	•	•	•	•	•
	PolyCut 47-3	4003 710 2117																	
	DuroCut 5-2	4006 710 2131			•														
	DuroCut 20-2	4002 710 2182	•	•	•	•	•	•	•	•	•	•	•	•	•	•	•	•	•
	DuroCut 40-4 ①	4005 710 2114																	

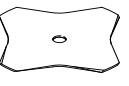
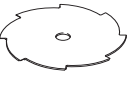
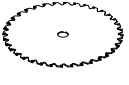
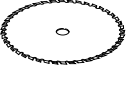
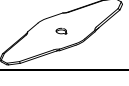
1	•									FS 160, 220, 260
	•									FS 235
										FS 235 R
	•									FS 240
	•									FS 240 R, 260 R, 460 R
	•									FS 250 R
1										FS 280, 290, 450, 460, 490
•				•						FS 311
•				5						FS 360 © , 400, 410
										FS 410 K, 460 K, 490 K
•										FS 510, 560
										FSA 45
										FSA 56, 57
										FSA 65, 85
									•	FSA 90
	•								•	FSA 90 R
	•								•	FSA 130
	•								•	FSA 130 R
										FSE 52
										FSE 60, 71, 81
									•	KM 56 R + FS-KM
									4	KM 55 R, 56 R, + FSB-KM
									3	KM 85 R, 91 R, 94 R, 111 R, + FS-KM
									3	KM 85 R, 91 R, 94 R, 111 R, + FSB-KM
									•	KM 131 + FS-KM
									•	KM 131 R + FS-KM
									•	KMA 130 R + FS-KM

			FR 131 T + FS-KM, FR 220	FR 235	FR 410, 450, 460, 480	FS 38, 40 ④, 45, 50 ④	FS 55, 56 ④, 70	FS 55 R, 56 R ④, 70 R	FS 80 ⑤, 85, 89	FS 80 R ⑤, 85 R, 89 R	FS 94	FS 94 R	FS 91, 111	FS 91 R, 111 R	FS 111 RX	FS 120 R	FS 120, 250	FS 131	FS 131 R
	ø 230-2	4001 713 3805	(•)	(•)	(•)		•	(•)	•	(•)	•	(•)	•	(•)		(•)	•	•	(•)
	ø 260-2	4001 713 3812	(•)	(•)	(•)				•	(•)	•	(•)	•	(•)		(•)	•	•	(•)
	ø 230-4	4000 713 3801																	
	ø 230-4	4001 713 3801	(•)	(•)	(•)		•	(•)	•	(•)	•	(•)	•	(•)		(•)	•	•	(•)
	ø 230-8	4001 713 3803	(•)	(•)	(•)		•	(•)	•	(•)	•	(•)	•	(•)		(•)	•	•	(•)
	ø 255-8	4000 713 3802																	
	ø 250-40	4000 713 3806																	
	ø 250-40	4001 713 3806	(•)		(•)				•	(•)			•	(•)		(•)	•	•	(•)
	ø 250-44	4000 713 3811																	
	ø 250-44	4001 713 3811	(•)		(•)				•	(•)			•	(•)		(•)	•	•	(•)
	ø 305-2	4000 713 4103																	
	ø 250-3	4112 713 4100	(•)	(•)	(•)				•	(•)			•	(•)		(•)	•	•	(•)
	ø 300-3	4119 713 4100																	
	ø 350-3	4000 713 41005																	
	ø 350-3	4110 713 4100																	
	ø 270-2	4000 713 3903																	
	ø 320-2	4000 713 3902																	

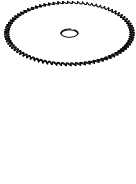
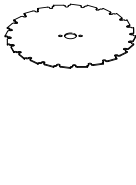
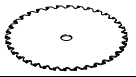
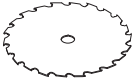
		FR 131 T + FS-KM, FR 220	FR 235	FR 410, 450, 460, 480	FS 38, 40 ④, 45, 50 ④	FS 55, 56 ④, 70	FS 55 R, 56 R ④, 70 R	FS 80 ⑤, 85, 89	FS 80 R ⑤, 85 R, 89 R	FS 94	FS 94 R	FS 91, 111	FS 91 R, 111 R	FS 111 RX	FS 120 R	FS 120, 250	FS 131	FS 131 R
	ø 200-44	4000 713 4200																
	ø 200-80	4112 713 4201						•				•				•	•	
	ø 225-48	4000 713 4205																
	ø 250-100	4001 713 4202																
	ø 200-22	4112 713 4203						•				•				•	•	
	ø 200-22	4119 713 4200																
	ø 225-24	4000 713 4201																
	ø 225-24	4110 713 4204																
	ø 225-36	4000 713 4211																
	ø 200-22 HP – High Performance	4000 713 4203																
	ø 200-22 HP – High Performance	4001 713 4203						•				•				•	•	
	ø 225-22 HP – High Performance	4000 713 4202																

•			•																				FS 160, 220, 260
	•																						FS 235
																							FS 235 R
																					•		FS 240
																							FS 240 R, 260 R, 460 R
																							FS 250 R
•																							FS 280, 290, 450, 460, 490
•																							FS 311
•																							FS 360 @ , 400, 410
•																							FS 410 K, 460 K, 490 K
•																							FS 510, 560
																							FSA 45
																							FSA 56, 57
																							FSA 65, 85
																							FSA 90
																							FSA 90 R
																							FSA 130
																							FSA 130 R
																							FSE 52
																							FSE 60, 71, 81
																							KM 56 R + FS-KM
																							KM 55 R, 56 R, + FSB-KM
																							KM 85 R, 91 R, 94 R, 111 R, + FS-KM
																							KM 85 R, 91 R, 94 R, 111 R, + FSB-KM
																							KM 131 + FS-KM
																							KM 131 R + FS-KM
																							KMA 130 R + FS-KM

Bemærk:

Informationer om skæreværktøjer til ældre modeller kan findes på de følgende sider.

Tegnforklaring:

- = deri indeholdt billednr.
- = tilladt
- (•) = **kun** tilladt til specialhåndtag med bøjle
- = ikke tilladt
- (A) = uden illustration
- (B) = kun specialtilbehør
- (C) = leveres ikke længere fra fabrikken
- (D) = enkeltvis ingen reservedel
- Ø = Diameter

Bemærkninger:

- ① til gevind M12 og M14
- ② til gevind M12
- ③ til gevind M14
- ④ fra 2008
- ⑤ fra 1996
- ⑥ fra 2006
- ❶ kun tilladt på FS 160, 220, 280 med et drev af typen 4128
- ❷ er ikke tilladt inden for EU, er uden for EU kun tilladt for specialhåndtag med bøjle
- ❸ fra 2018 til gevind M8
- ❹ til 2017 til gevind M12
- ❺ kun tilladt til FS 360

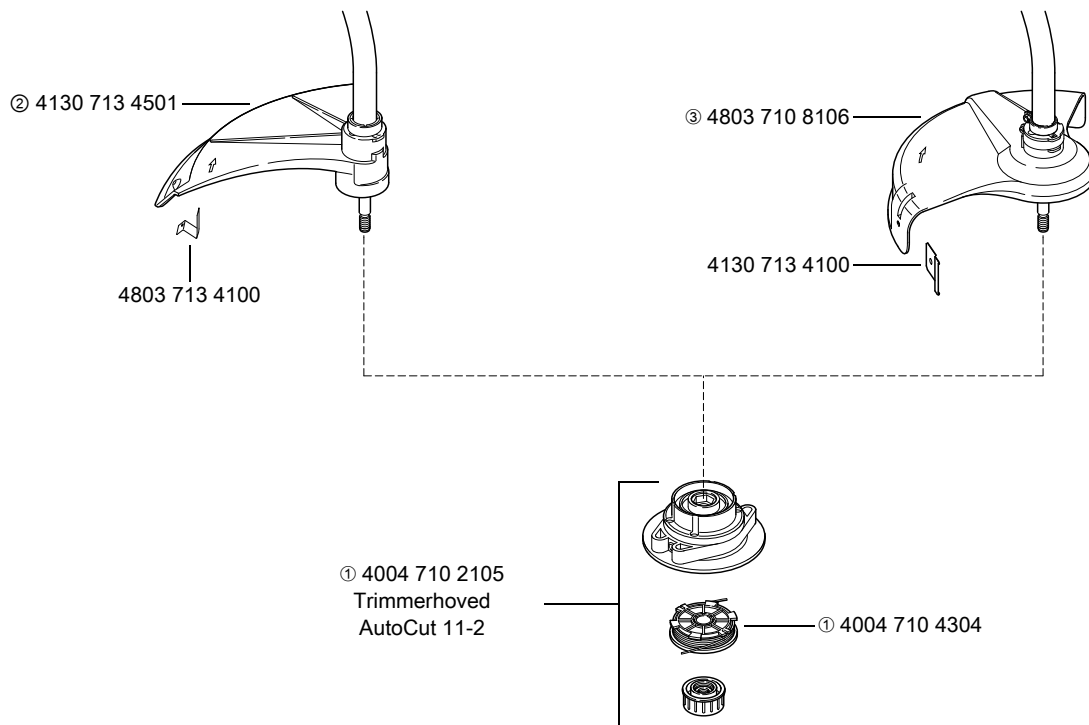

681KT568 KN

① Anvend støjsvag trimmertråd

② Ikke tilladt inden for EU

③ Denne del er lovmæssigt påkrævet inden for EU

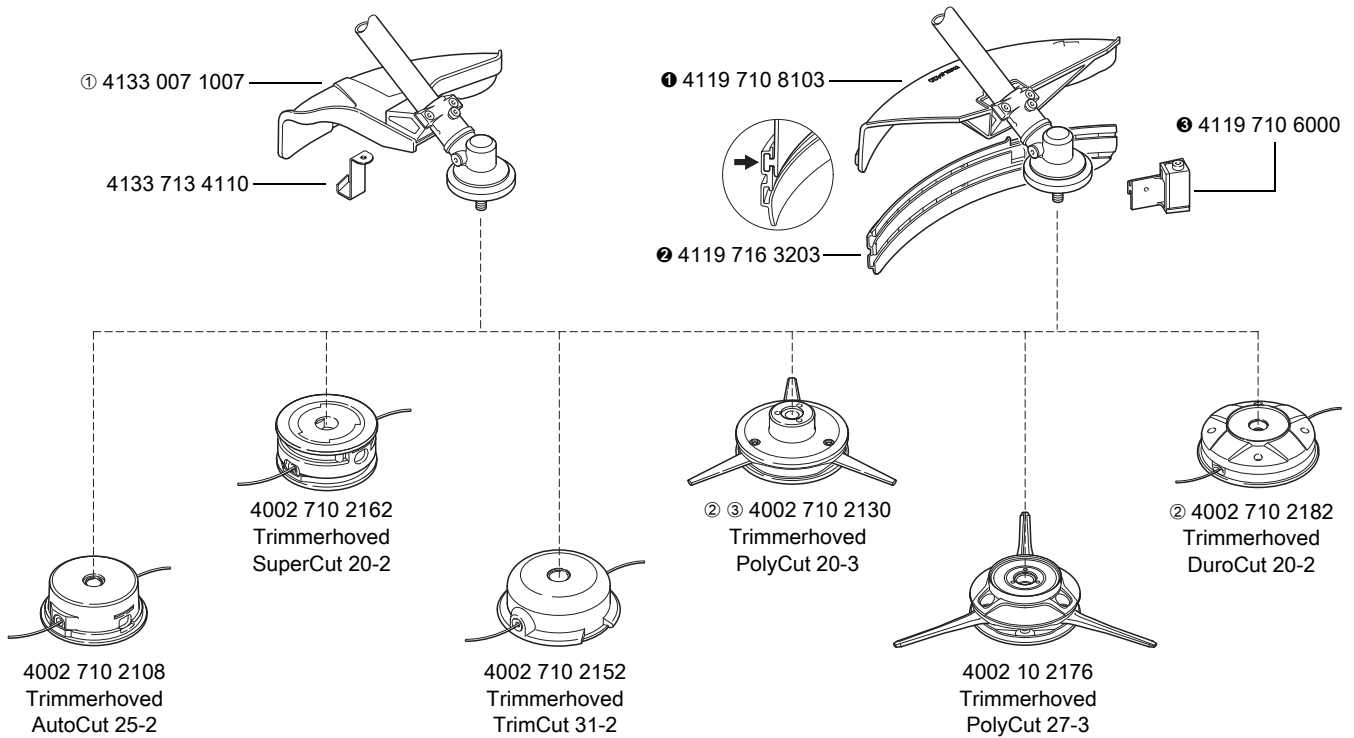

0000-GXX-5725-A0

① Kun tilladt i AUS, NZ: 4133 007 1008

③ Leveres ikke længere

② Ikke tilladt i FR 106, 108

① + ② + ③ = 4119 007 1027

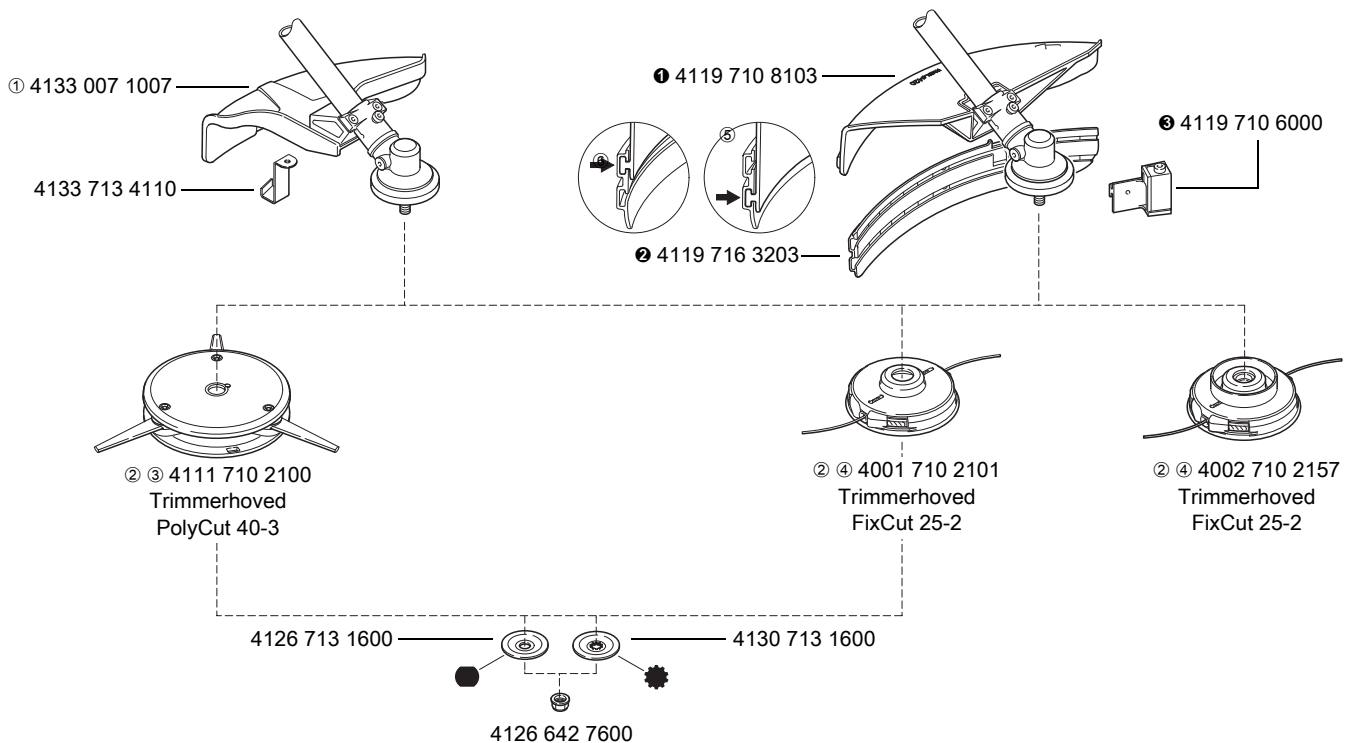

381KT856-A1

① Kun tilladt i AUS, NZ: 4133 007 1008

Til 4111 710 2100

② Leveres ikke længere

⑥ Til 4001 710 2101, 4002 710 2157

③ Ikke tilladt til FR 85, 85 T

① + ② + ③ = 4119 007 1027

④ Ikke tilladt til FR 106, 108

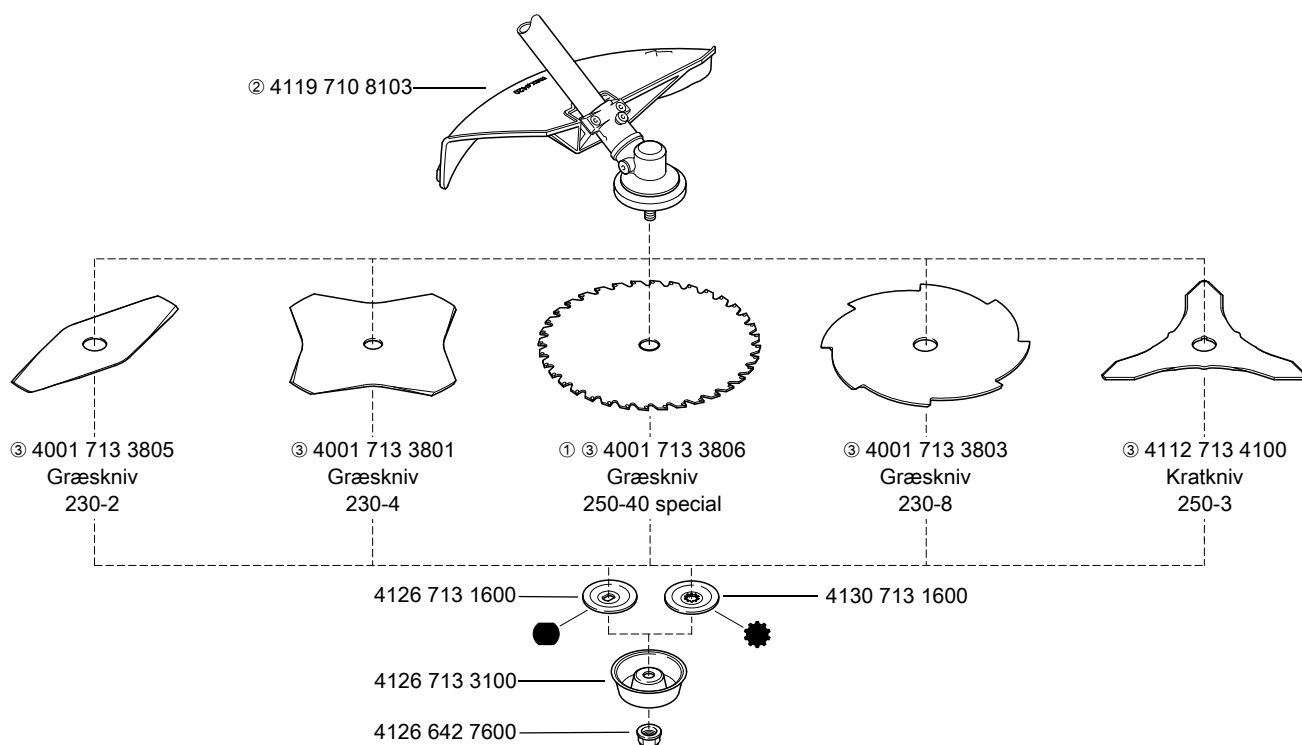

681KT857 KN

① Ikke tilladt til FR 106, 108

② Beskyttelse til AUS, NZ se billedet med "AUS, NZ"

③ På specialhåndtaget kræves en skridtbegrænser (bøjle)

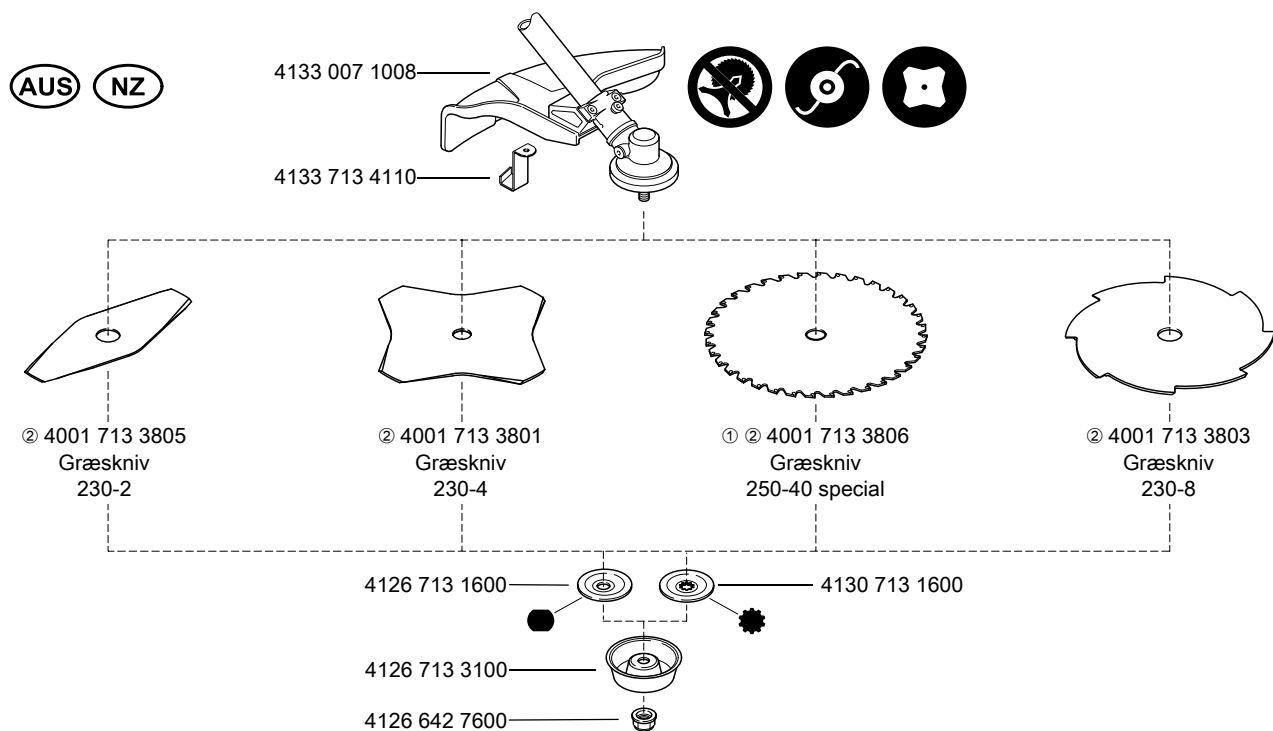

681KT582 KN

① Ikke tilladt til FR 106, 108

② På specialhåndtaget kræves en skridtbegrænser (bøjle)

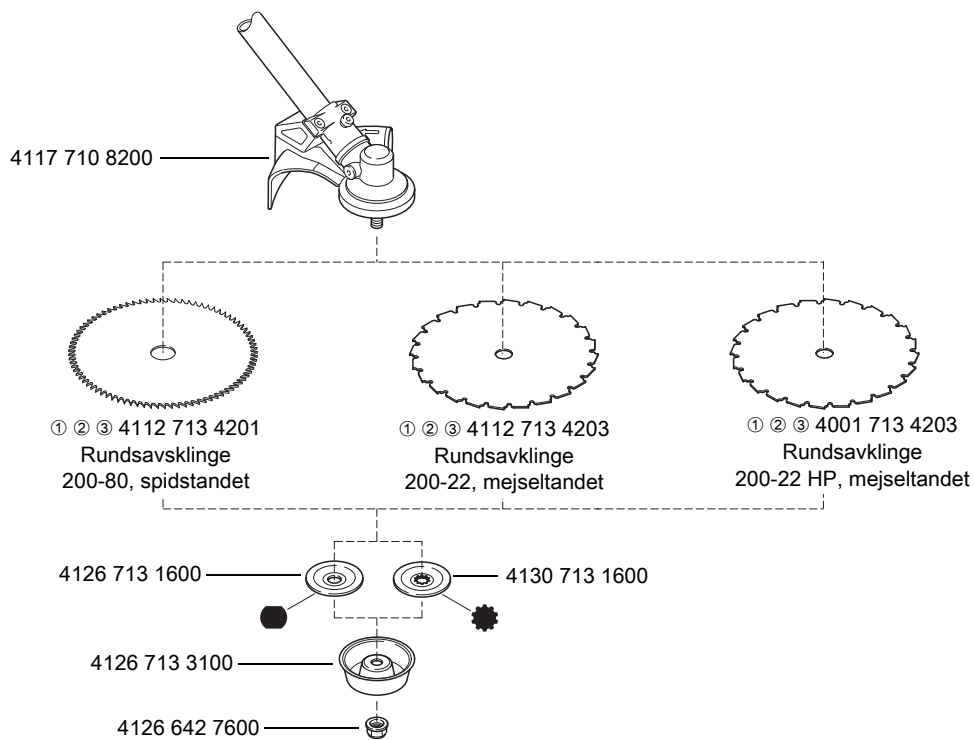

681KT868-A1

① Ikke tilladt til FR 85, FR 85 T

② På specialhåndtaget kræves en skridtbegrænser (bøjle)

③ Kun tilladt til fjernelse af døde kviste og afgang

(a) indtil 2017

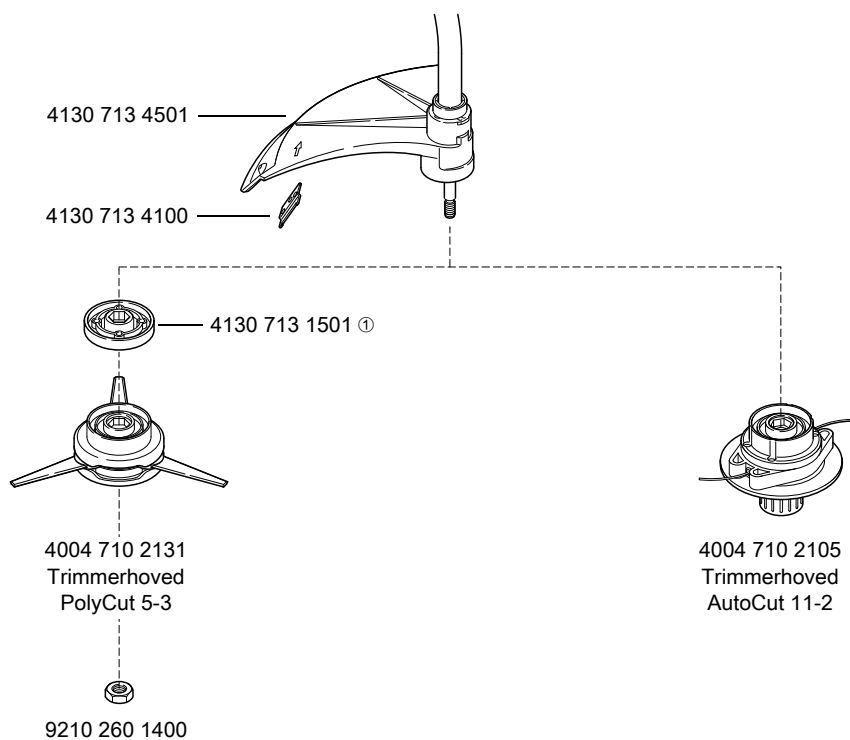

① Denne del leveres sammen med trimmerhovedet

(a) fra 2015 (b) fra 2017

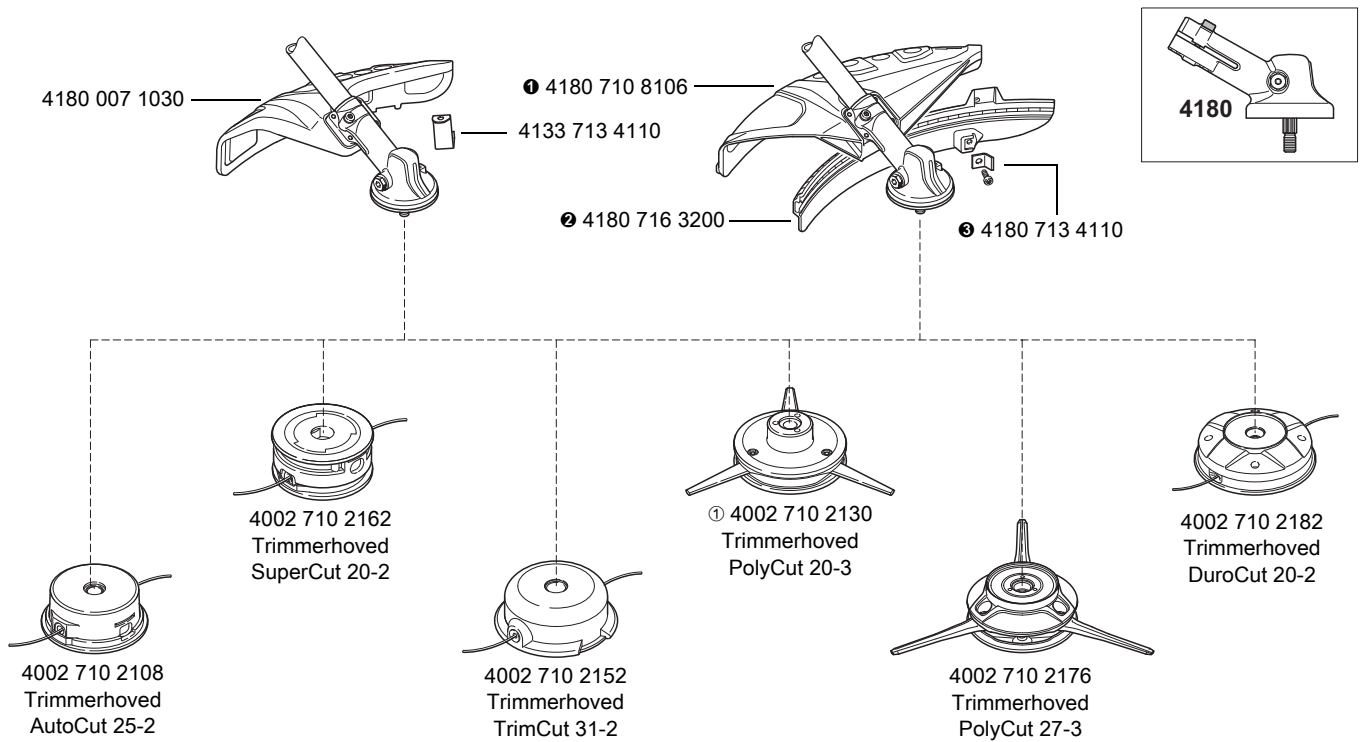

① Leveres ikke længere

❶ + ❷ + ❸ = 4180 007 1028

0000-GXX-5726-A0

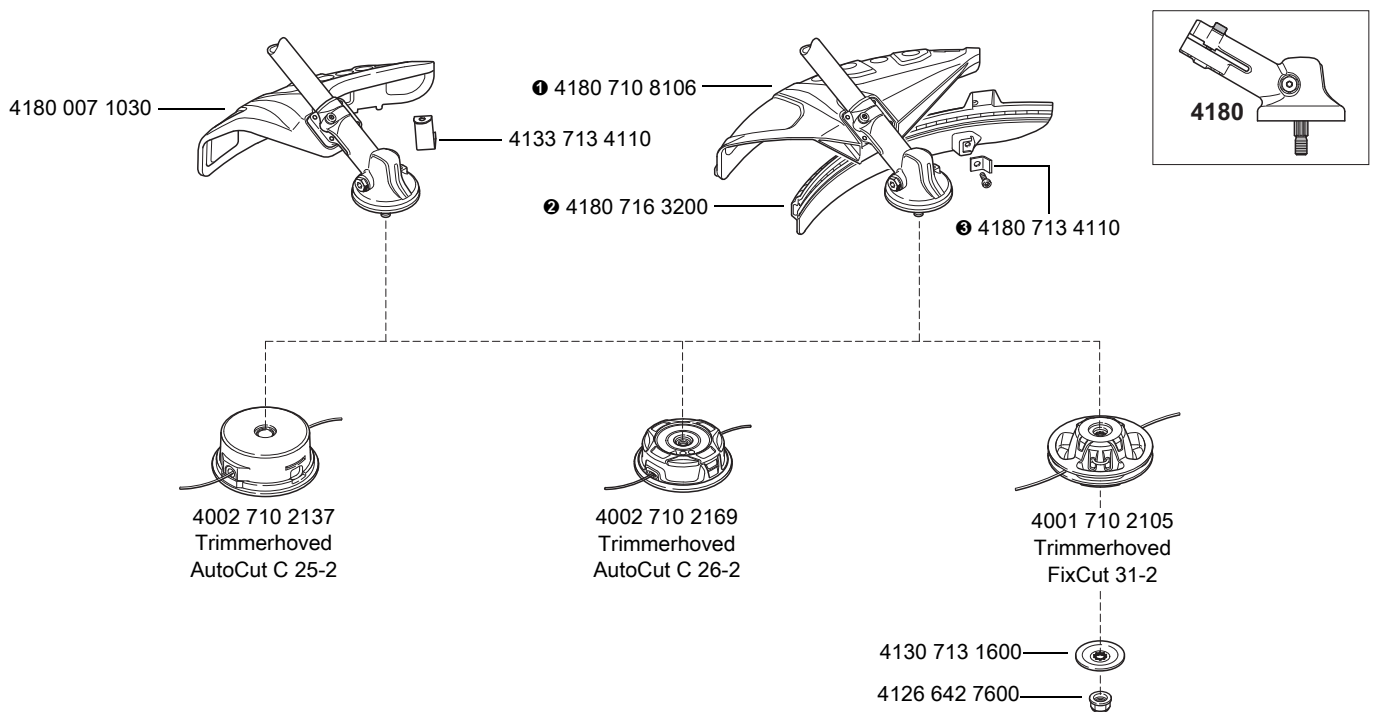

❶ + ❷ + ❸ = 4180 007 1028

0000-GXX-5694-A0

(a) fra 2015 (b) fra 2017

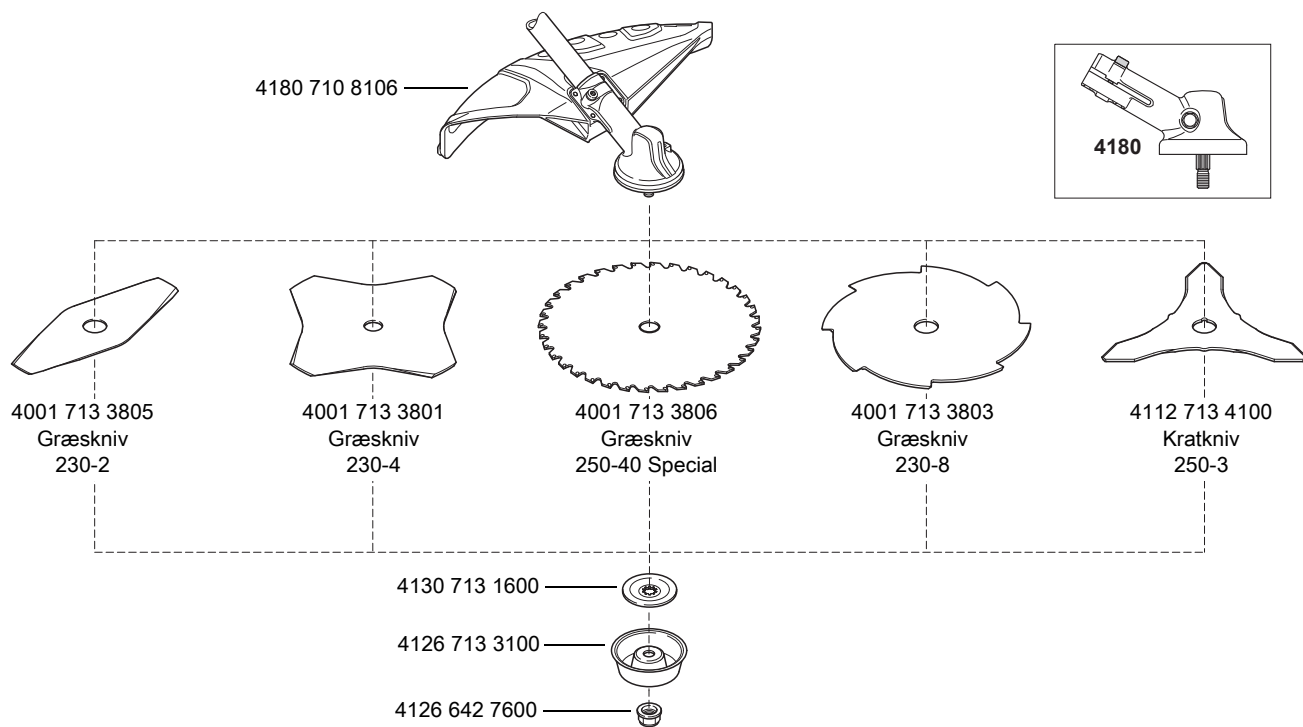

81KT1062 KN

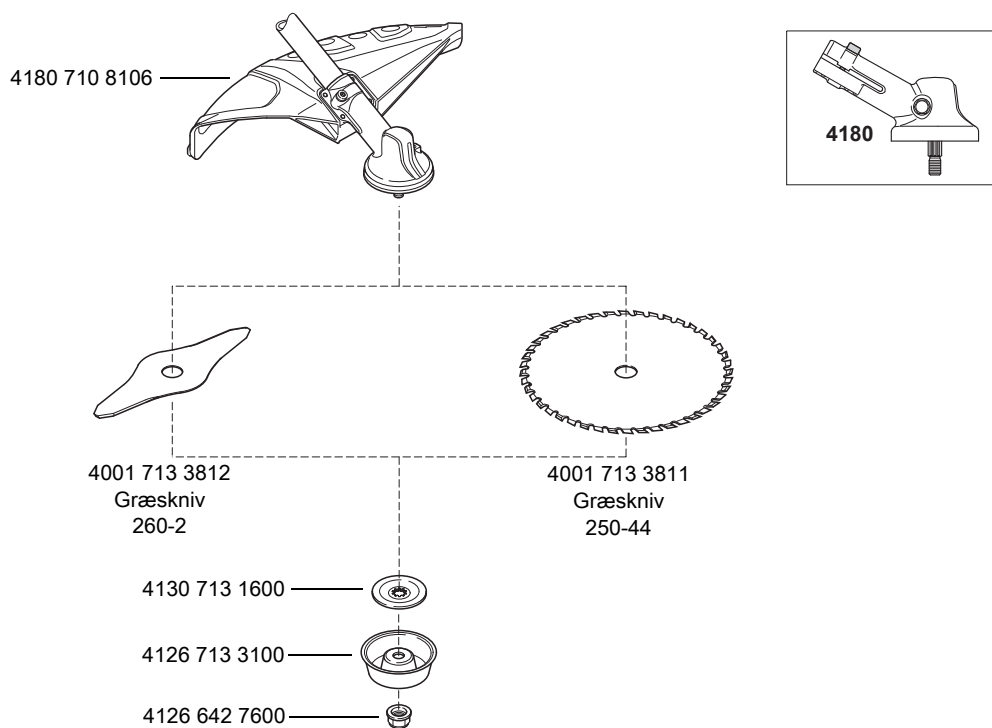

881KT1063 KN

(a) indtil 2015 (b) indtil 2017

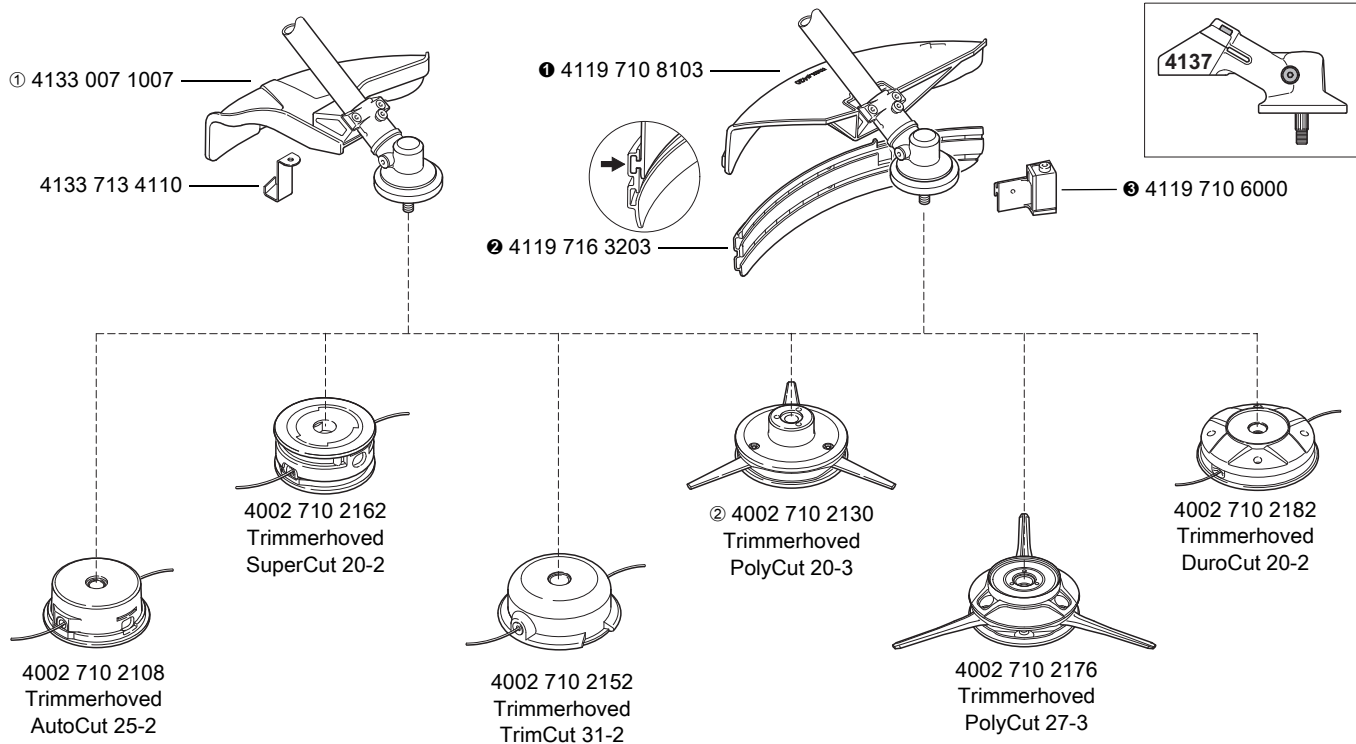

0000-GXX-5727-A0

① Kun tilladt i AUS, NZ: 4133 007 1008

② Leveres ikke længere

① + ② + ③ = 4119 007 1027

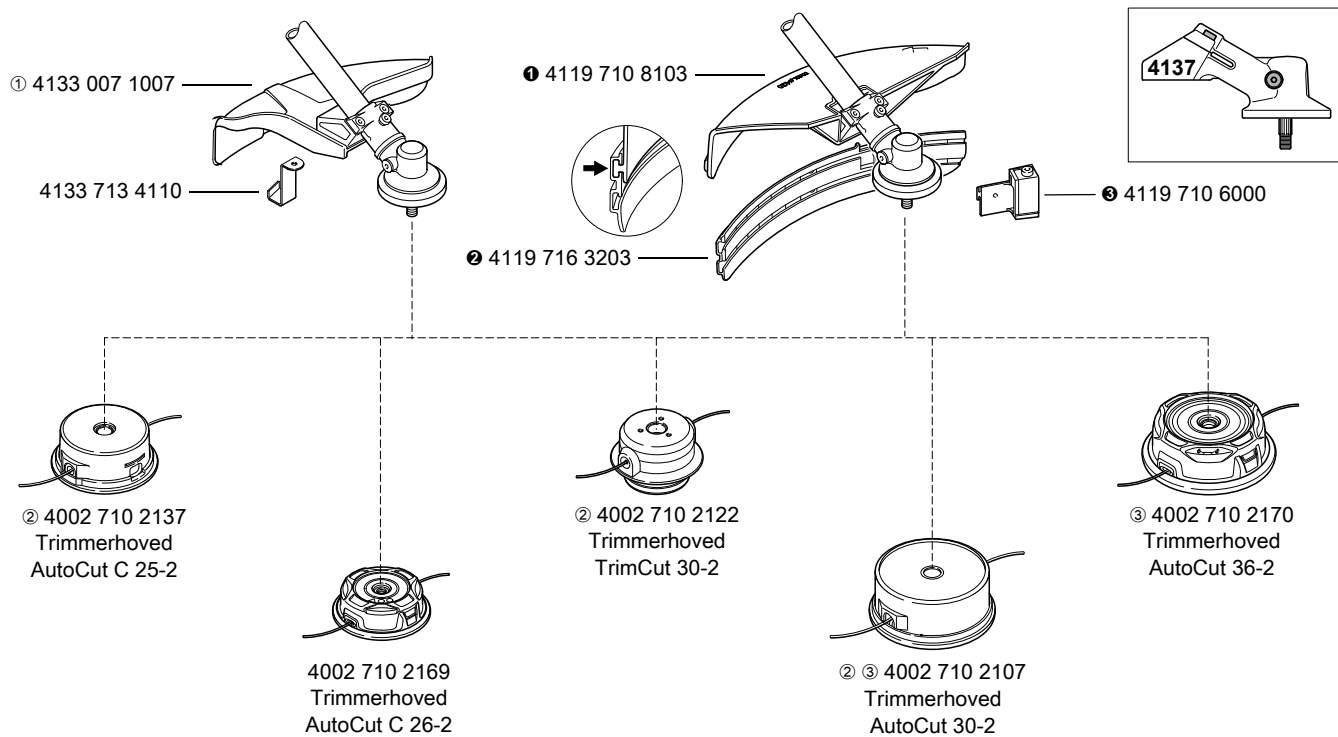

0000-GXX-3441-A0

① Kun tilladt i AUS, NZ: 4133 007 1008

① + ② + ③ = 4119 007 1027

② Leveres ikke længere

③ Ikke tilladt i FR 130 T

(a) indtil 2015 (b) indtil 2017

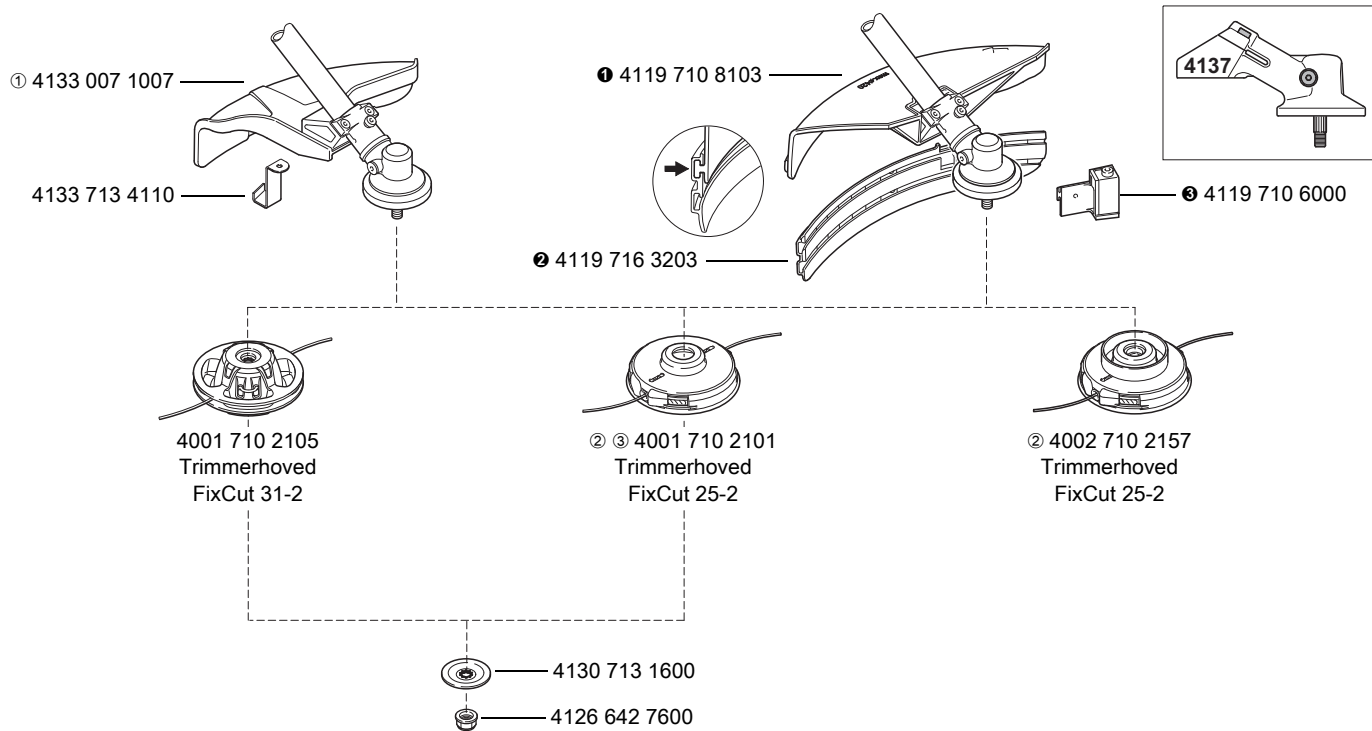

000-GXX-5795-A0

① Kun tilladt i AUS, NZ: 4133 007 1008

① + ② + ③ = 4119 007 1027

② Leveres ikke længere

③ Ikke tilladt i FR 410, 460

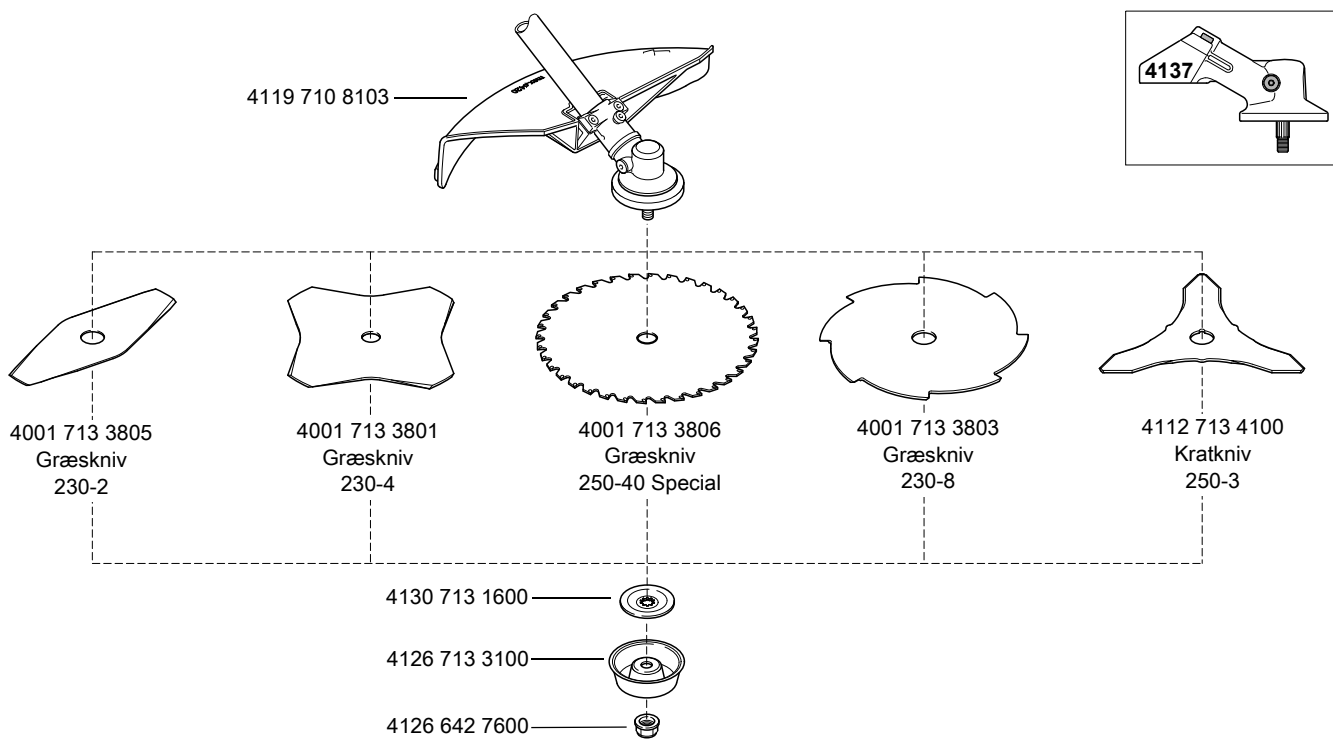

881KT1057 KN

(a) indtil 2015 (b) indtil 2017

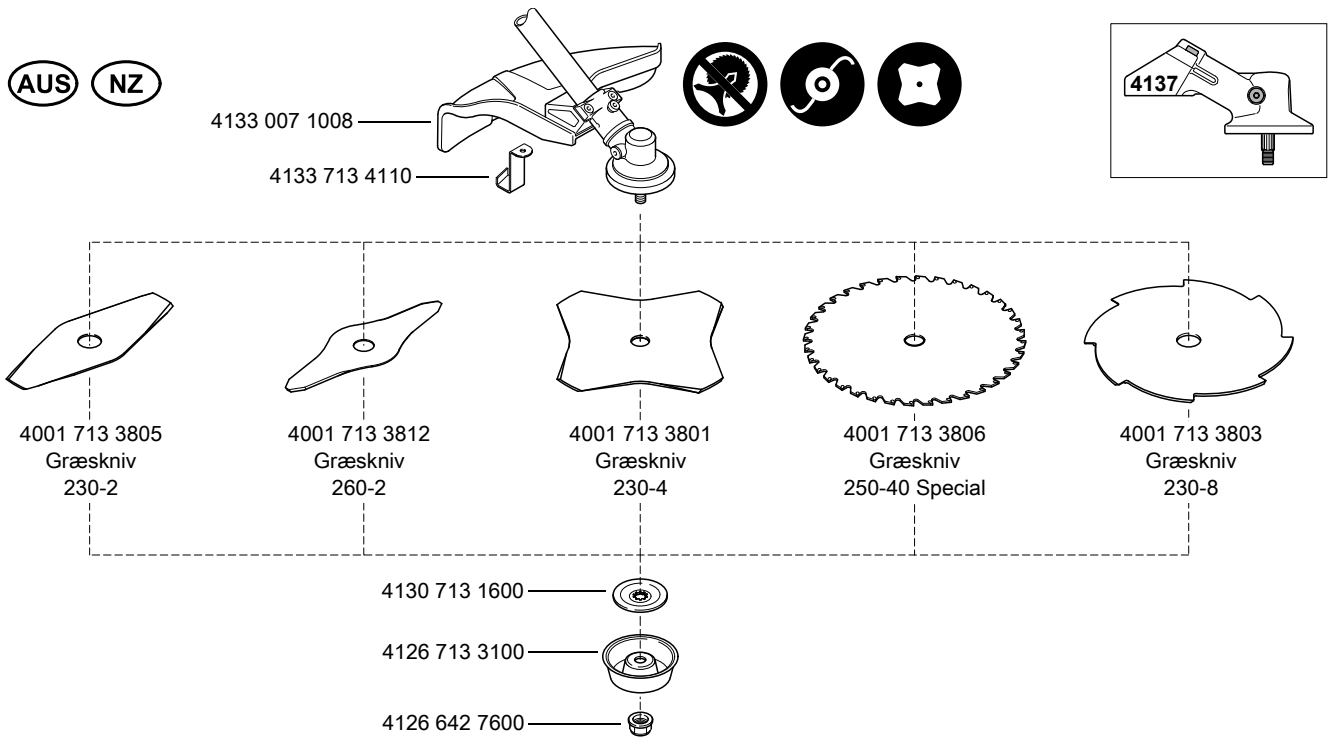
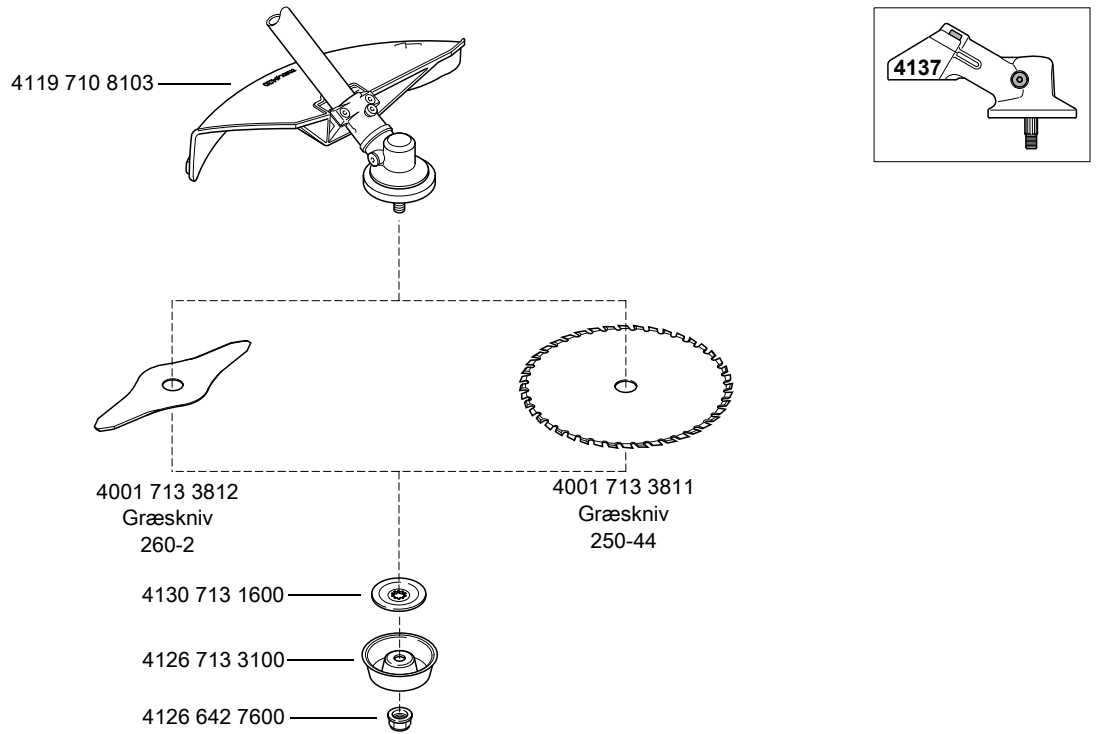

(a) indtil 2015 (b) indtil 2017

AUS NZ

4133 007 1008

4133 713 4110

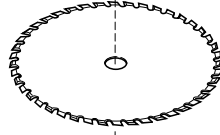
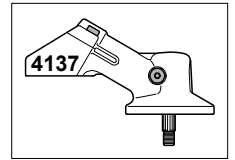
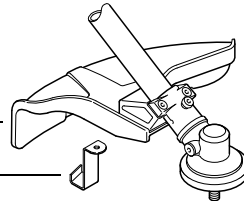

① ② 4001 713 3811
Græskniv
250-44

4130 713 1600



4126 713 3100



4126 642 7600



681KT1124 KN

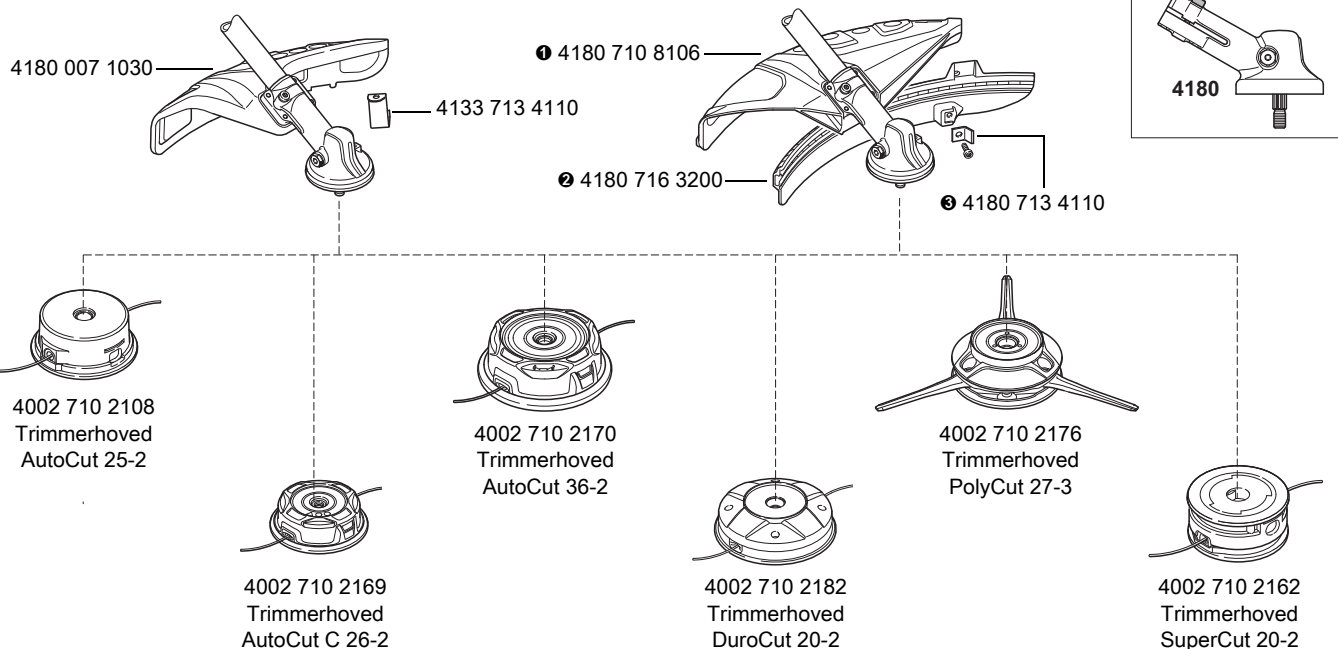

0000-GX

1 + 2 + 3 = 4180 007 1028

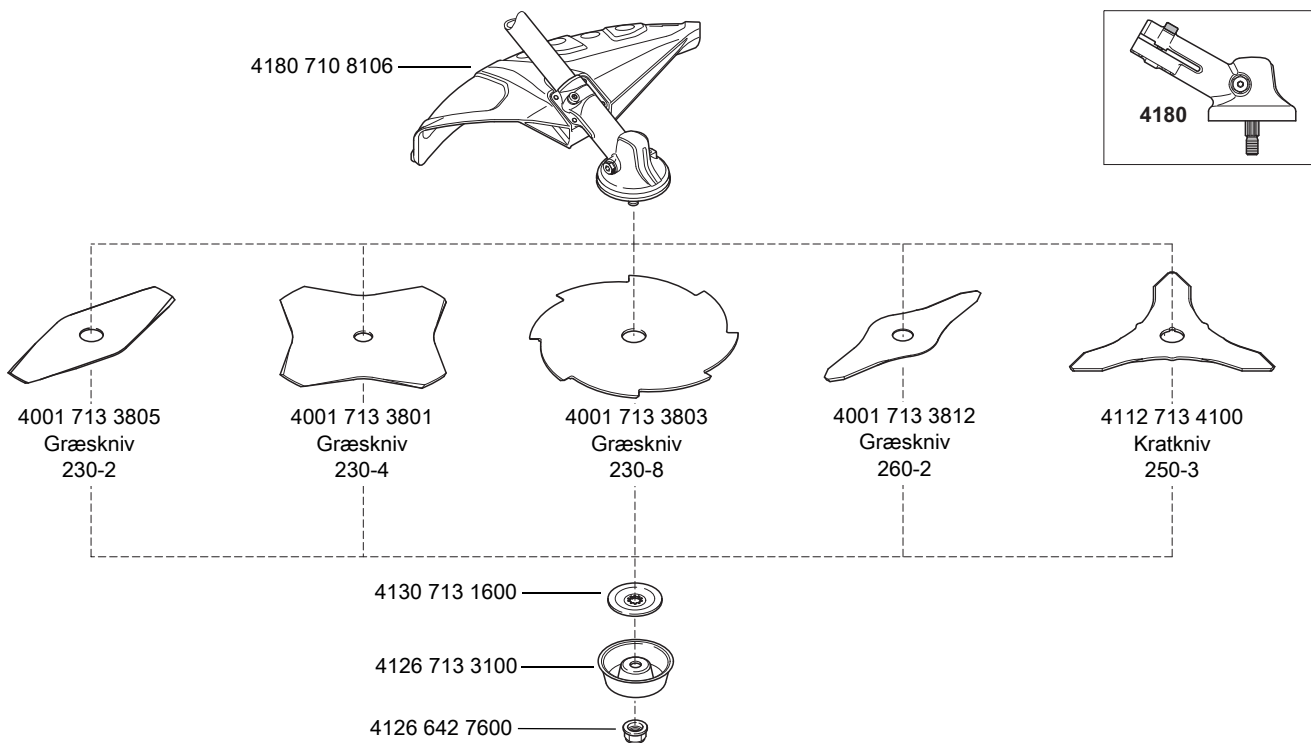

0000-GXX-8231-A0

(a) indtil 2014

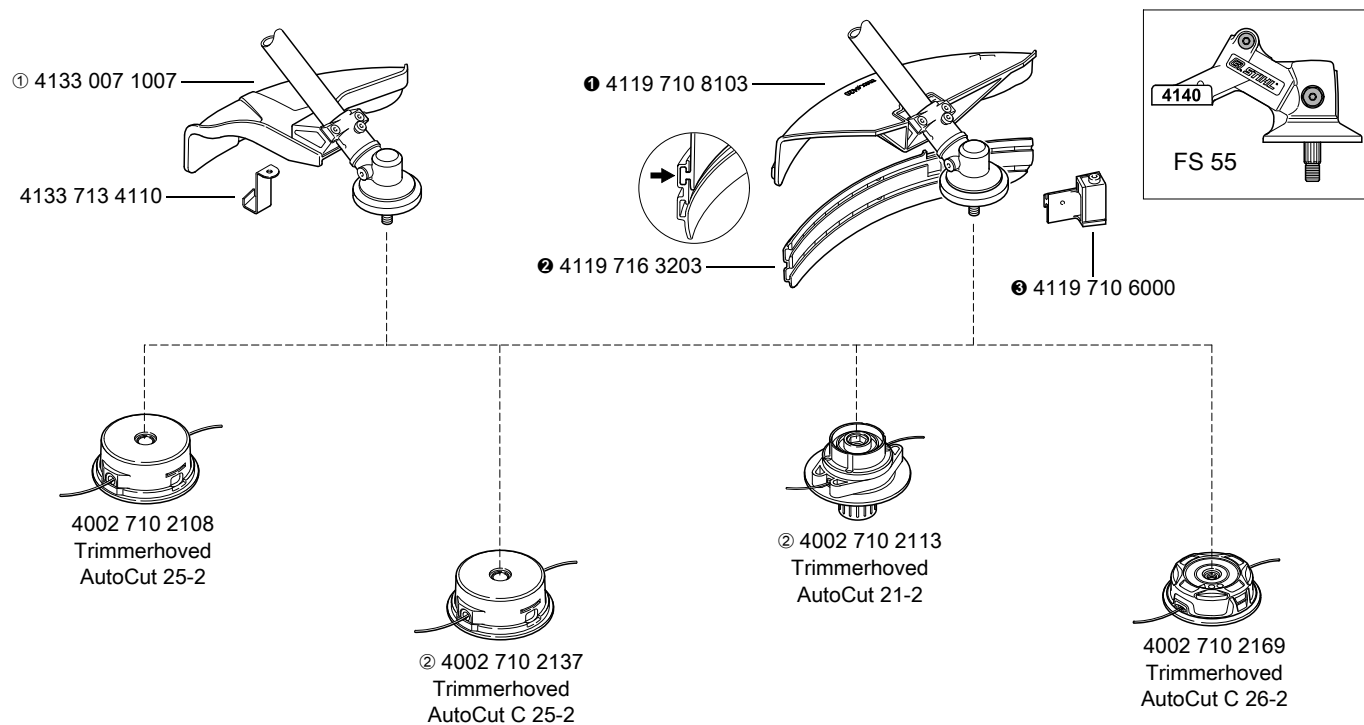

0000-GXX-3442-A0

① Kun tilladt i AUS, NZ: 4133 007 1008

② Leveres ikke længere

① + ② + ③ = 4119 007 1027

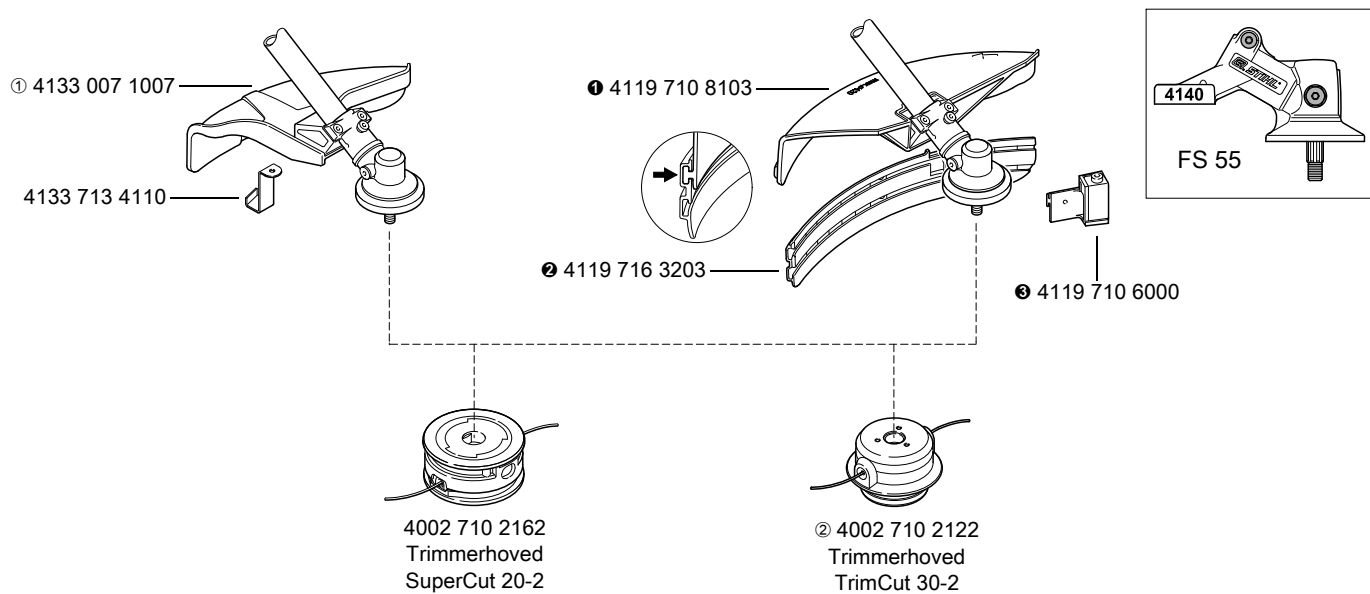

0000-GXX-3443-A0

① Kun tilladt i AUS, NZ: 4133 007 1008

② Leveres ikke længere

① + ② + ③ = 4119 007 1027

(a) indtil 2014

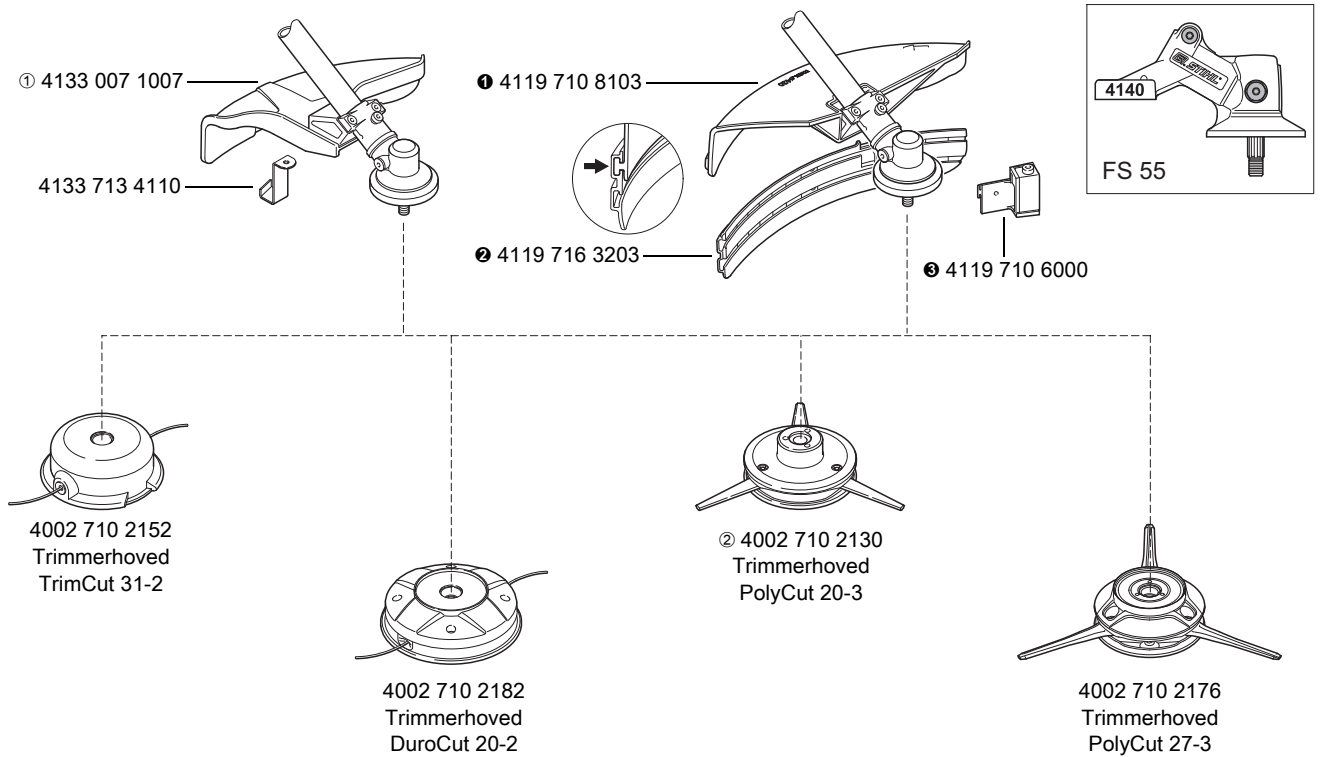

0000-GXX-5728-A0

① Kun tilladt i AUS, NZ: 4133 007 1008

② Leveres ikke længere

① + ② + ③ = 4119 007 1027

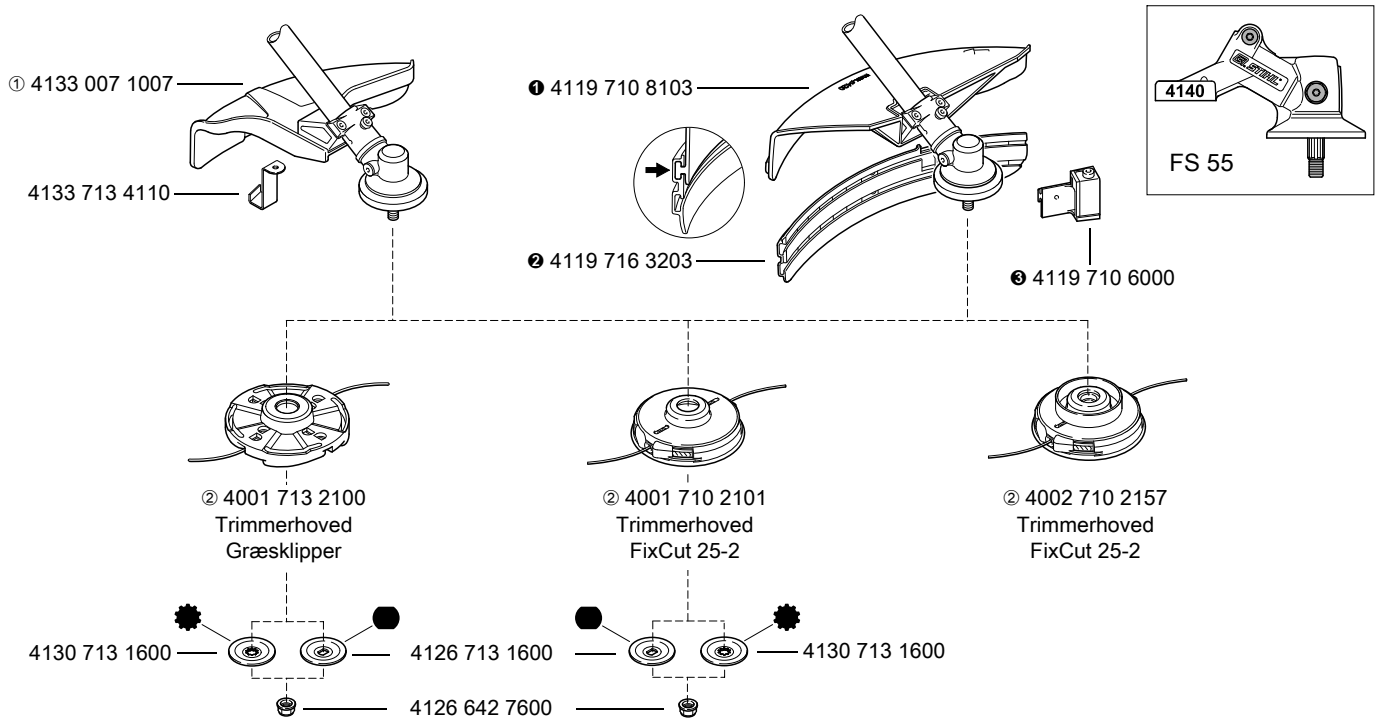

381KT92 KN

① Kun tilladt i AUS, NZ: 4133 007 1008

② Leveres ikke længere

① + ② + ③ = 4119 007 1027

(a) indtil 2014

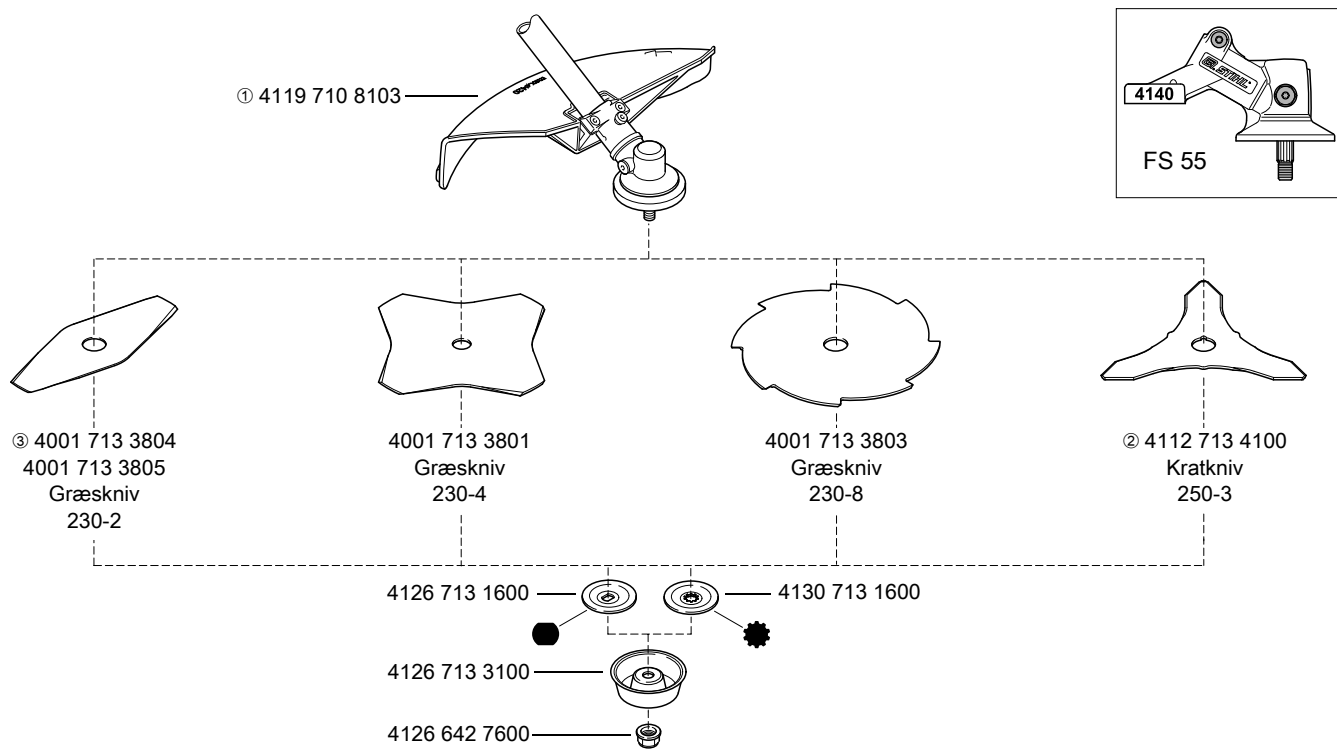

681KT510 KN

① Beskyttelse til AUS, NZ, se billedet med "AUS, NZ"

② Ikke tilladt til FS 44, 55, 55 T

③ Leveres ikke længere

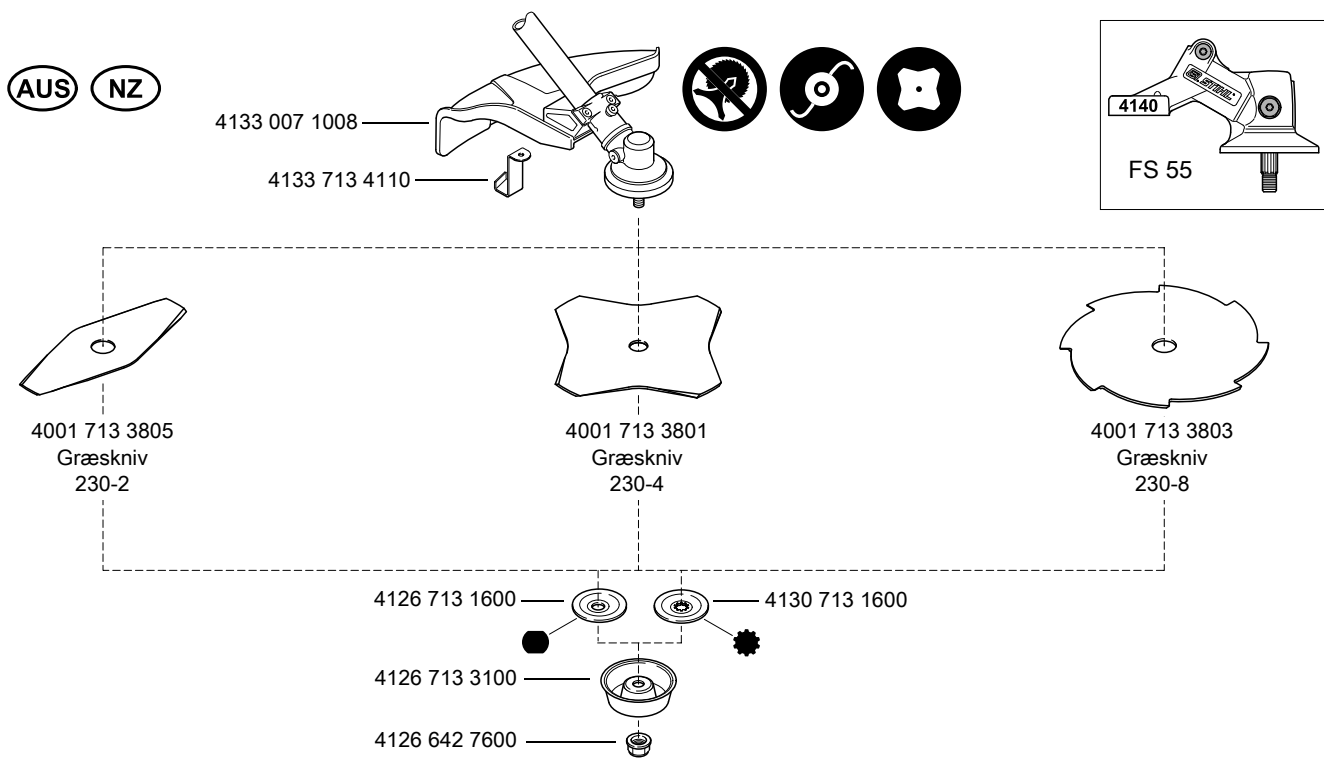

381KT862 KN

(a) indtil 1999

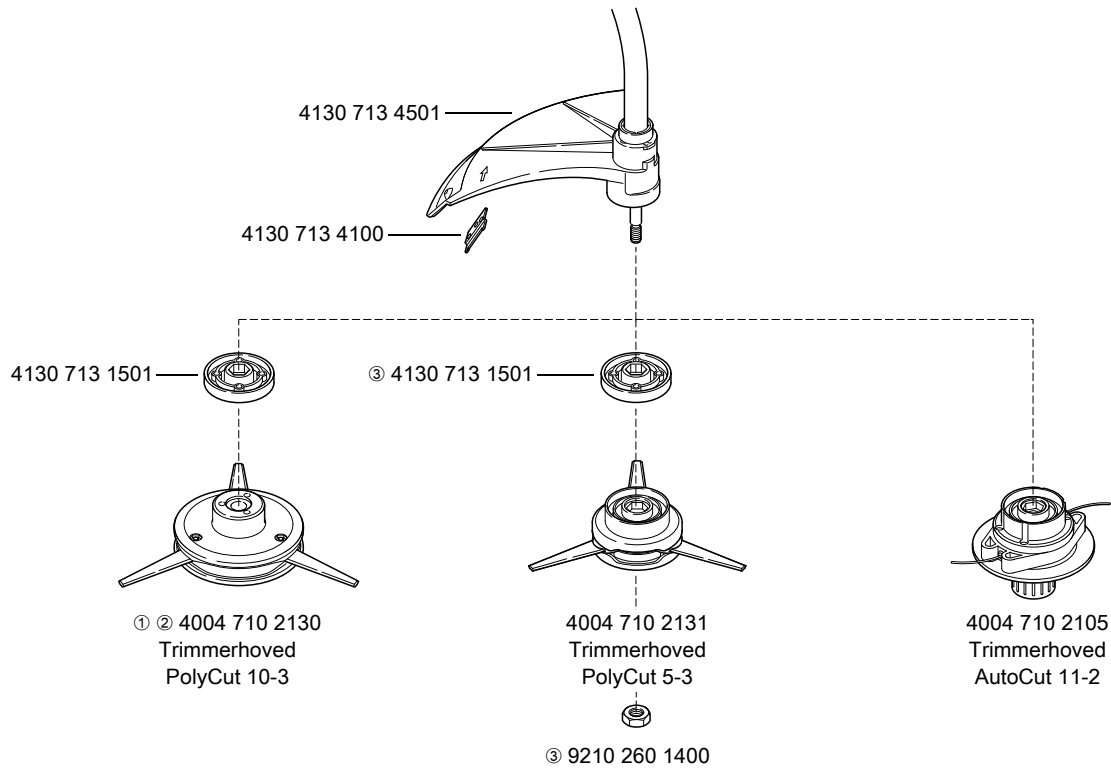

① Ikke tilladt til FS 36

② Leveres ikke længere

③ Delen leveres sammen med trimmerhovedet

681KT567 KN

(a) fra 2008

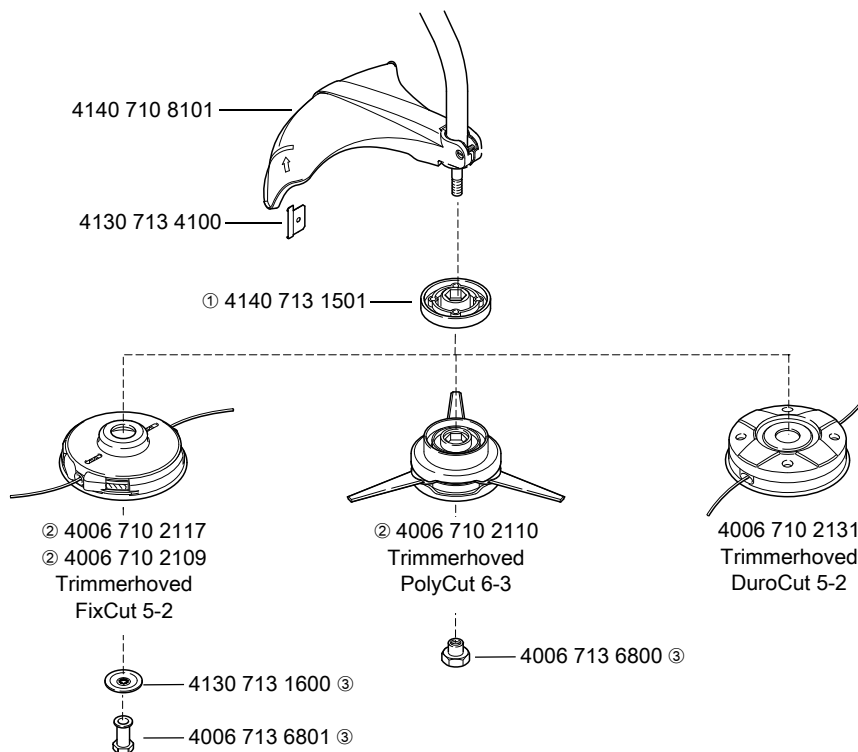

0000-GXX-8898-A0

① Delen leveres sammen med trimmerhovedet

② Leveres ikke længere

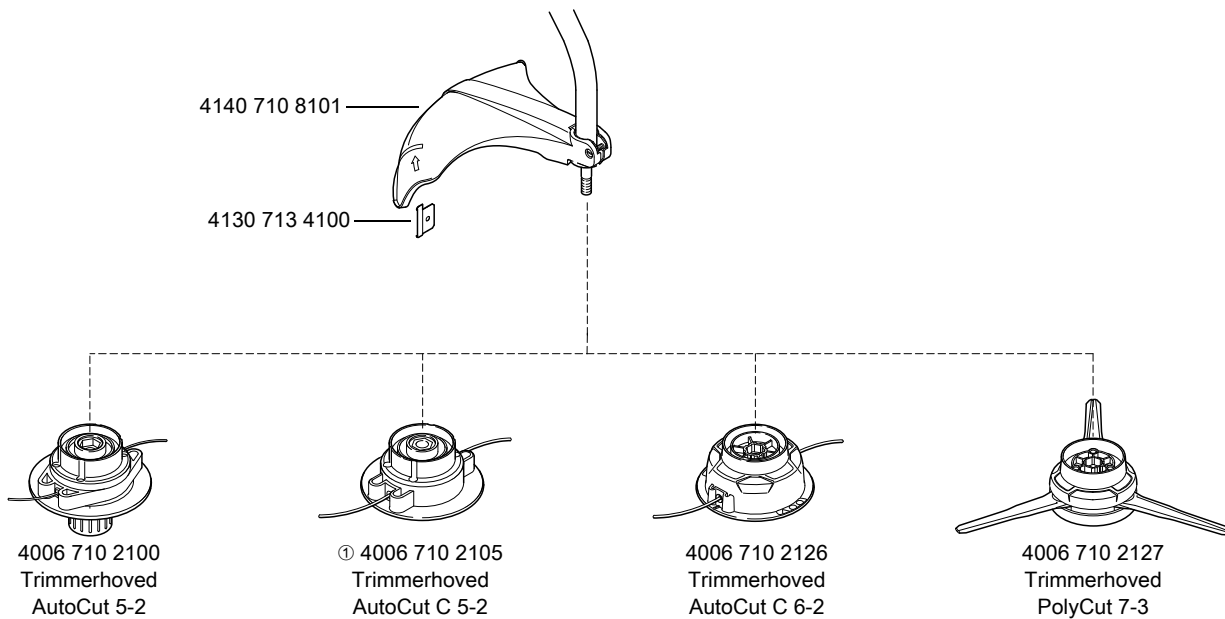

0000-GXX-8899-A0

① Leveres ikke længere

(a) fra 2008

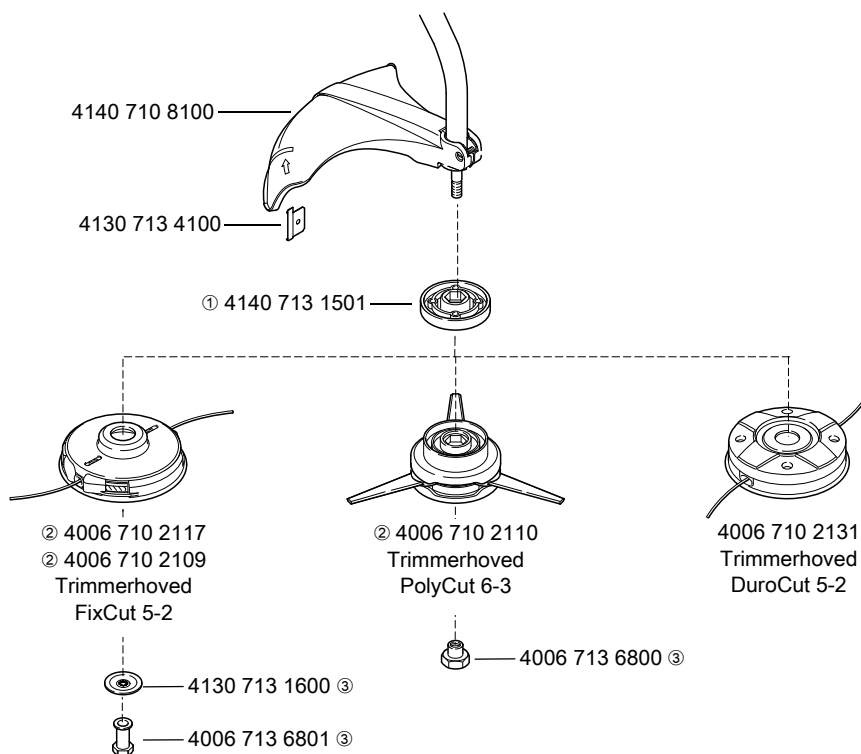

0000-GXX-8900-A0

① Delen leveres sammen med trimmerhovederne PolyCut 6-3 og FixCut 5-2

② Leveres ikke længere

③ Delen leveres sammen med trimmerhovedet

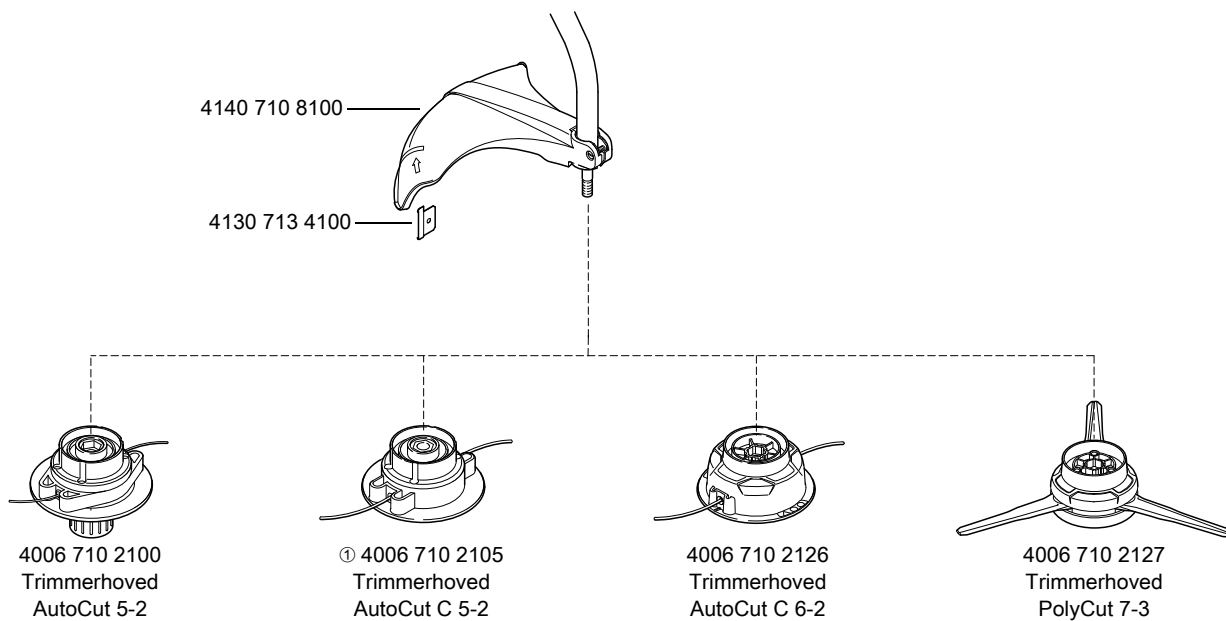

0000-GXX-8901-A0

① Leveres ikke længere

(a) indtil 1984 (b) indtil 1995

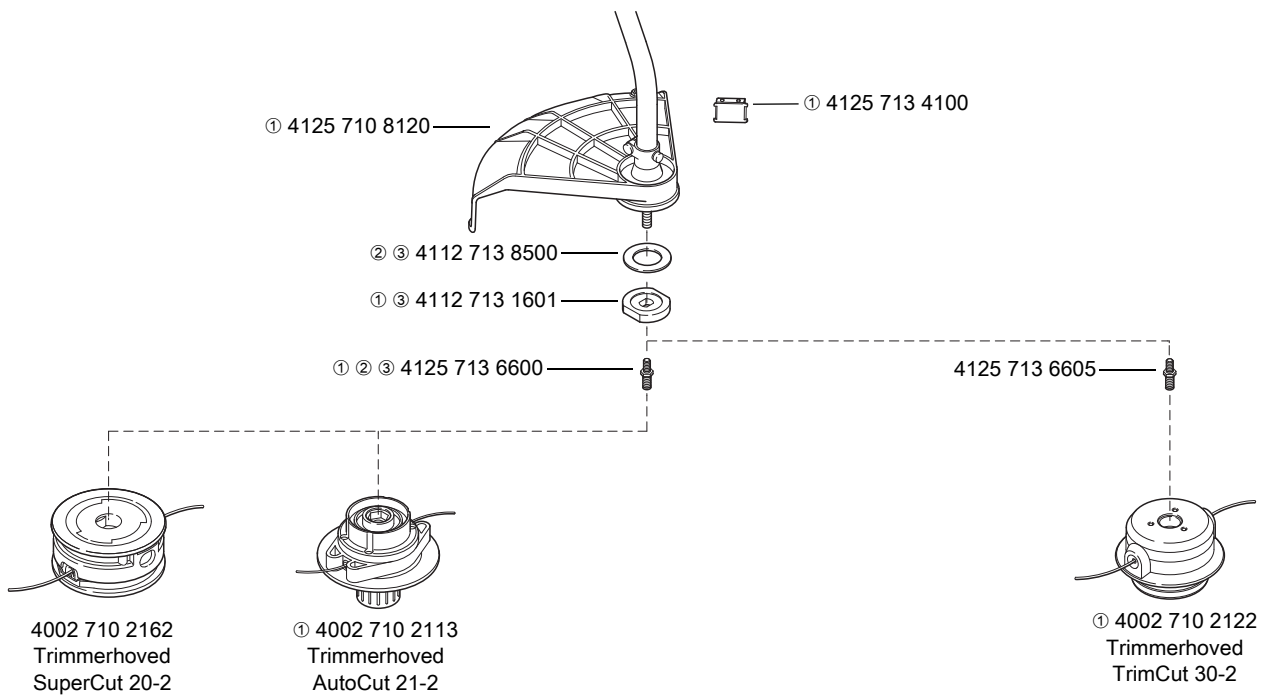

- ① Leveres ikke længere
- ② Specialtilbehør
- ③ Kun nødvendig til FS 50, 51

(a) fra 2014 (b) fra 2008

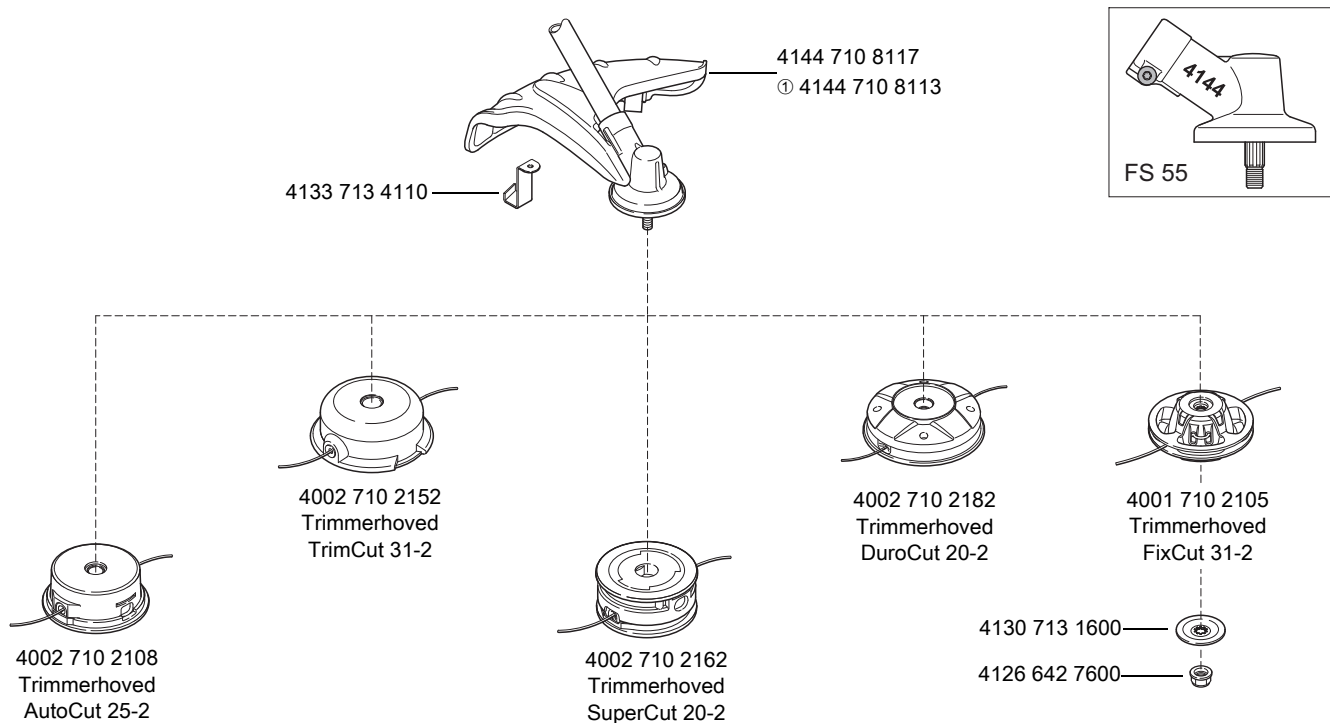

0000-GXX-5686-A1

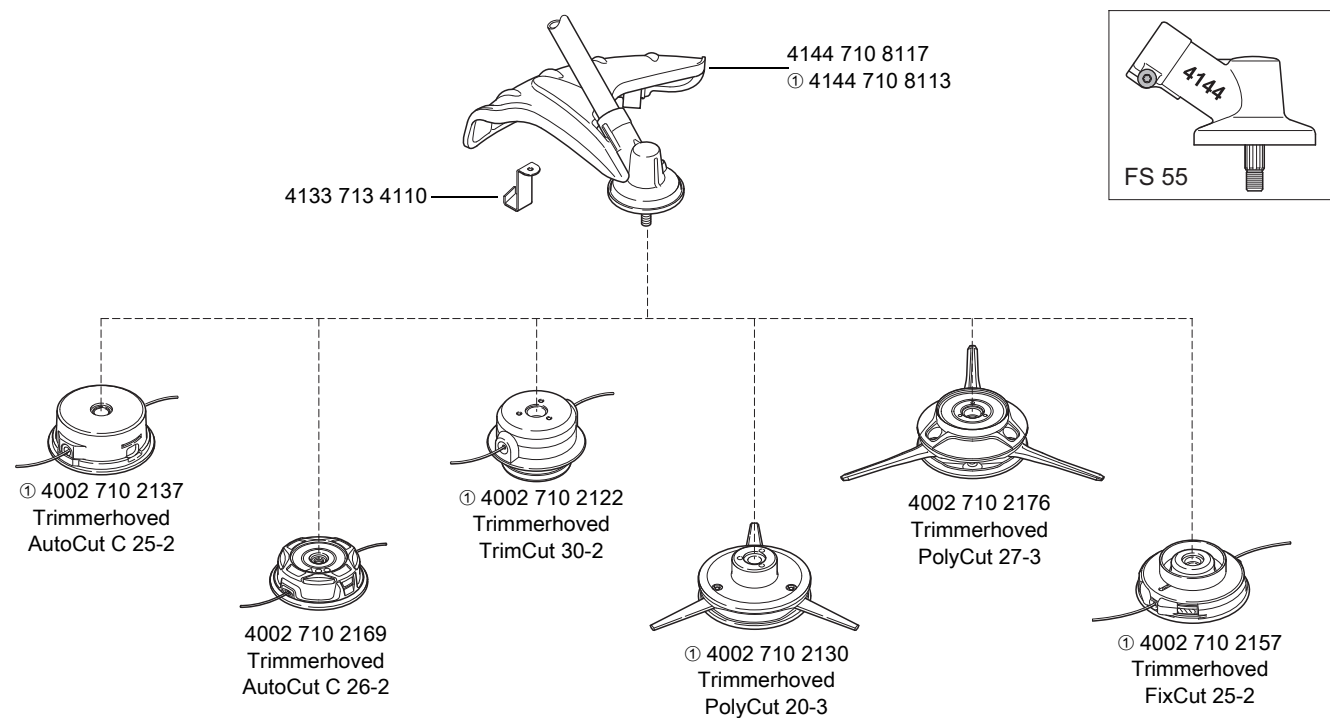

0000-GXX-5731-A0

① Leveres ikke længere

(a) fra 2014 (b) fra 2008

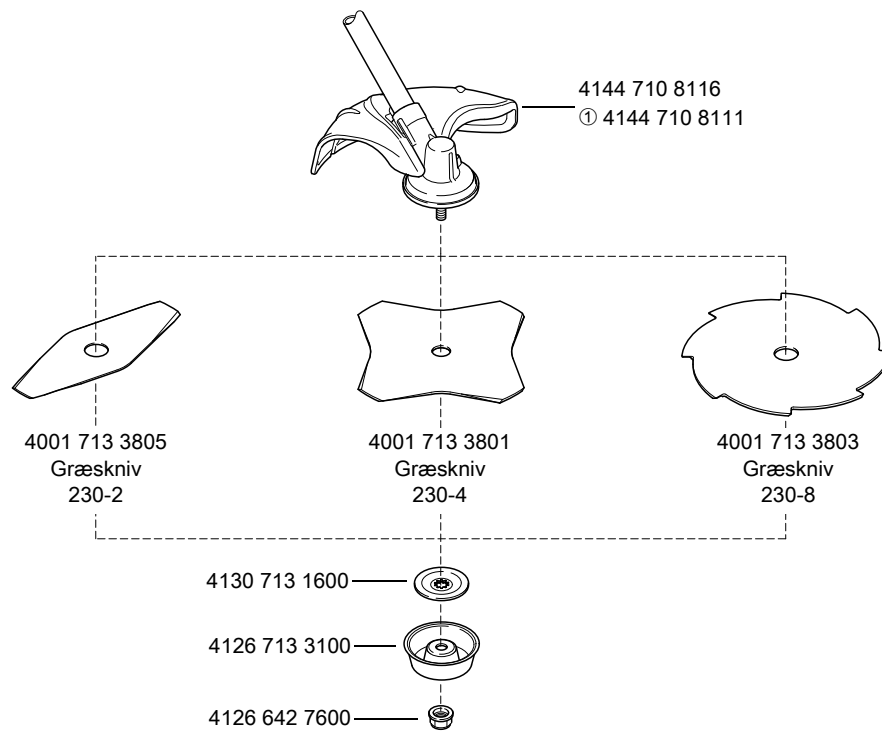

681K794 KN

① Leveres ikke længere

(a) indtil 1986

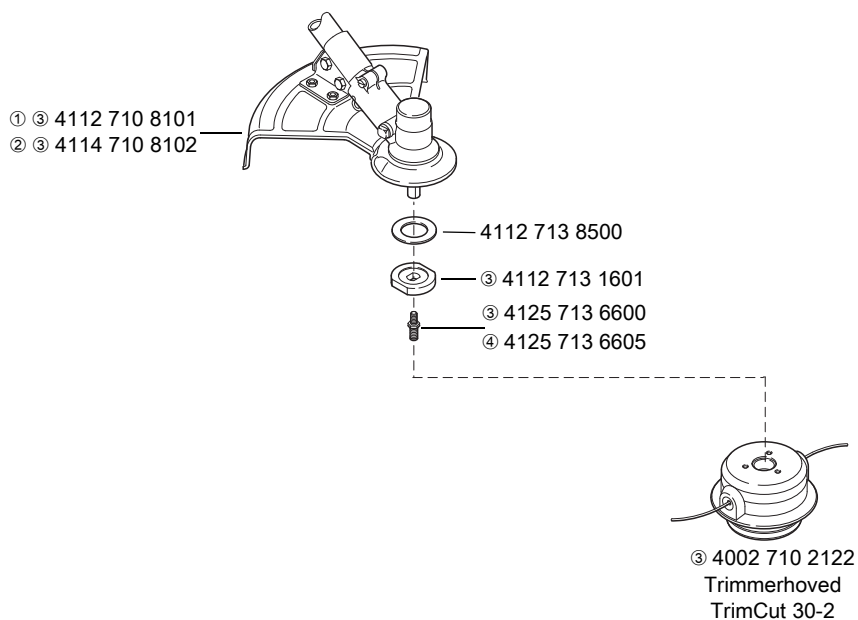

681KT949-A1

① Til FS 80, 90

④ Specialtilbehør til TrimCut 30-2

② Til FS 65

③ Leveres ikke længere

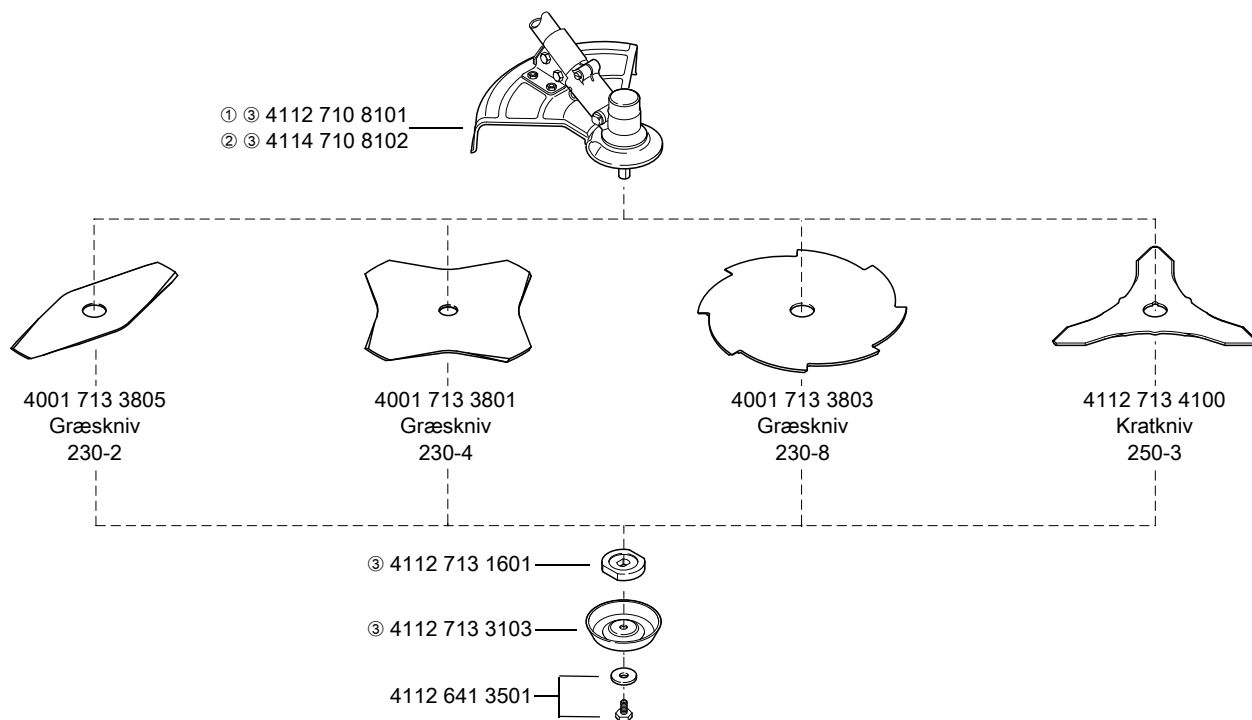

681KT515 KN

① Til FS 80, 90

② Til FS 65

③ Leveres ikke længere

(a) indtil 1986

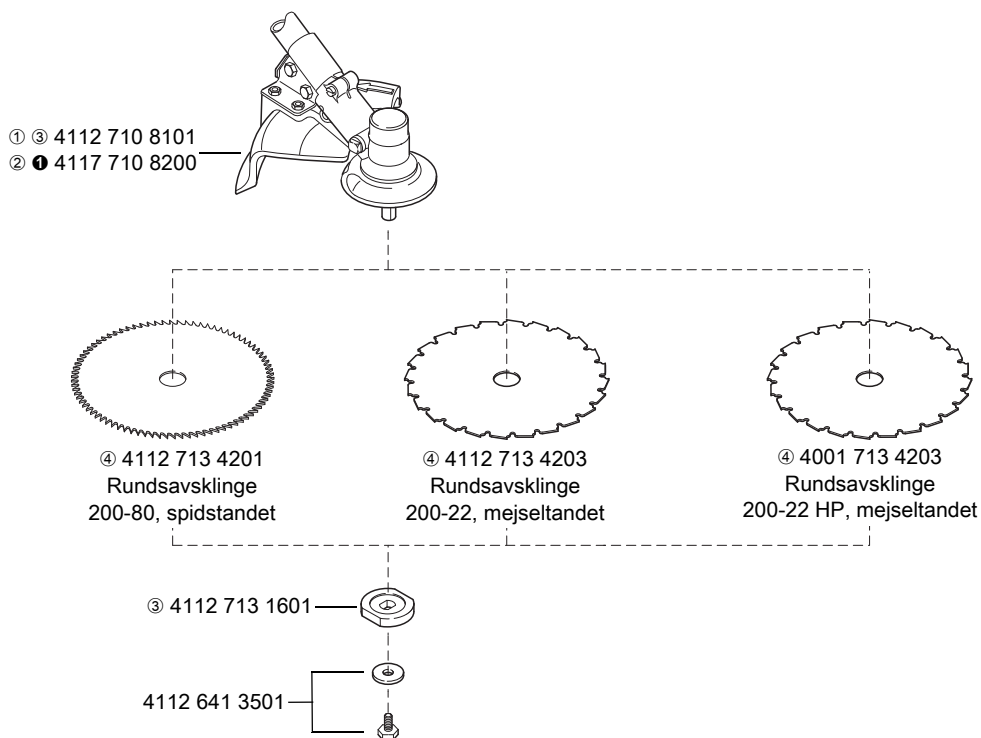

681KT516-A1

① Til FS 80, 90

① + Transportbeskyttelse = 4126 007 1002

② Til FS 65, 90

③ Leveres ikke længere

④ Ikke tilladt på trimmere med specialhåndtag

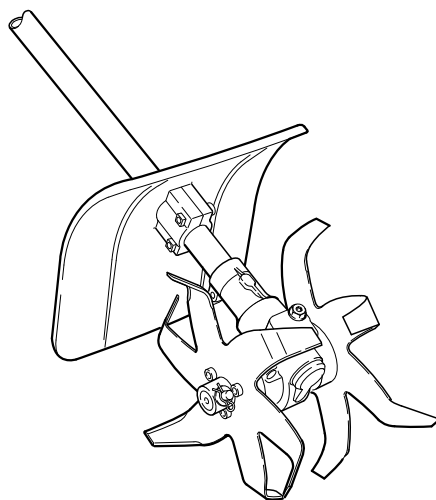

①②③ 4600 710 1500
Jordkultivator BC 30

681KT517 KN

① Til FS 65, FS 80 fra maskinnummer X 5 168 100, FS 90

② Leveres ikke længere

③ Ikke tilladt på trimmere med specialhåndtag

(a) fra 2017

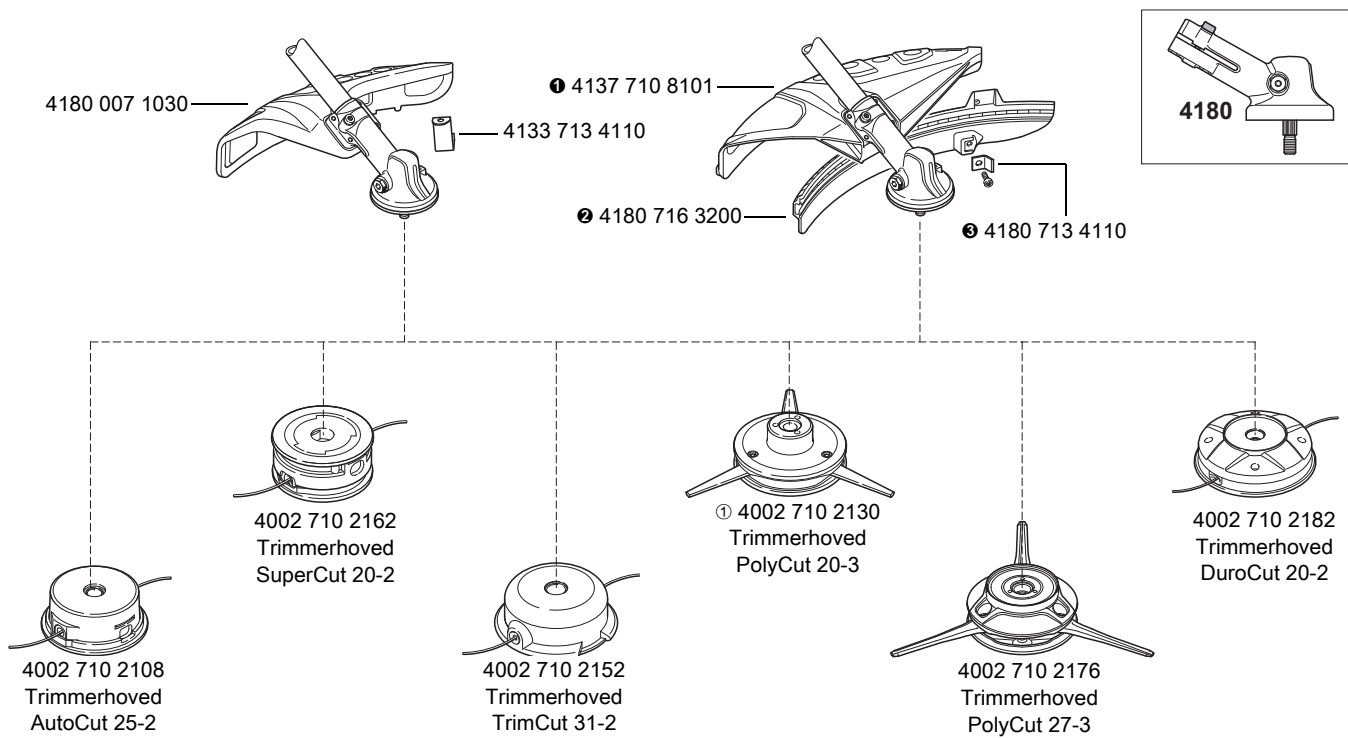

0000-GXX-5733-A0

① Leveres ikke længere

① + ② + ③ = 4137 007 1040

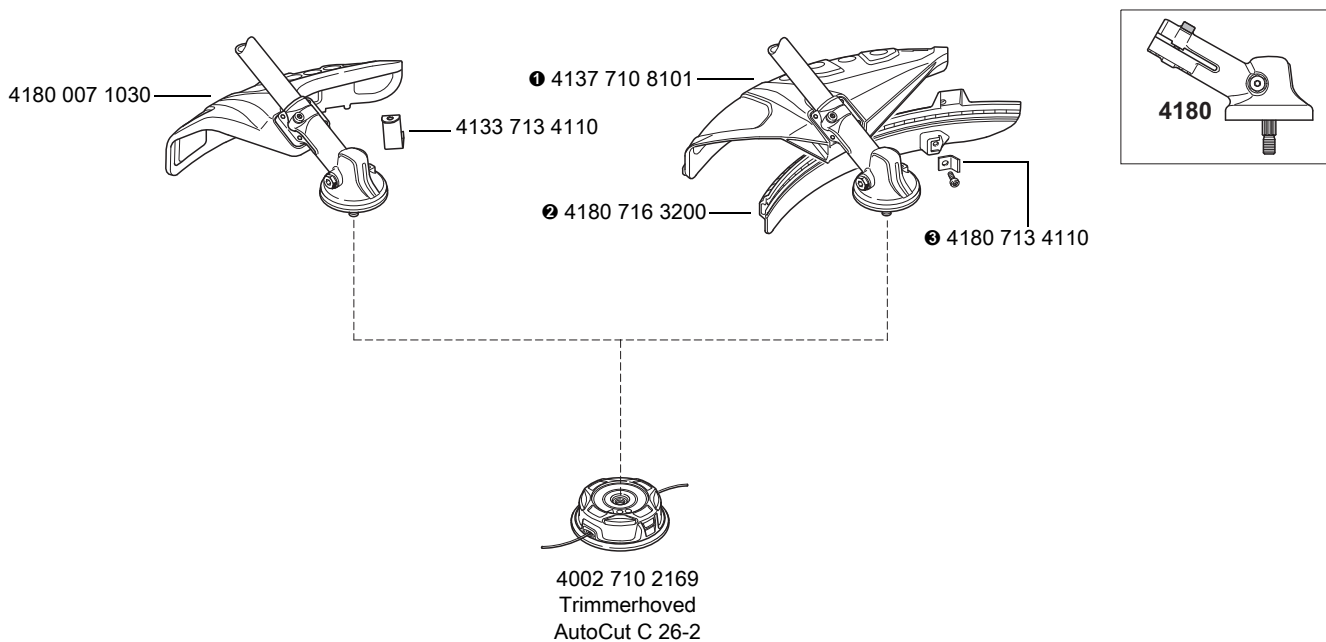

0000-GXX-5699-A0

① + ② + ③ = 4137 007 1040

(a) fra 2017

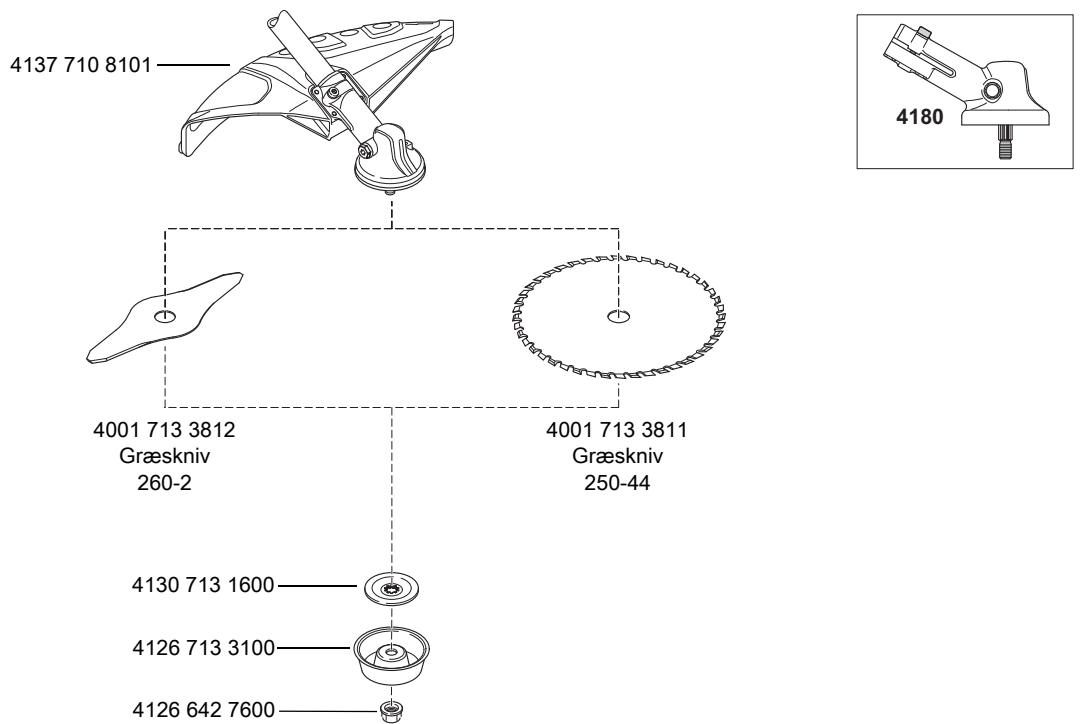
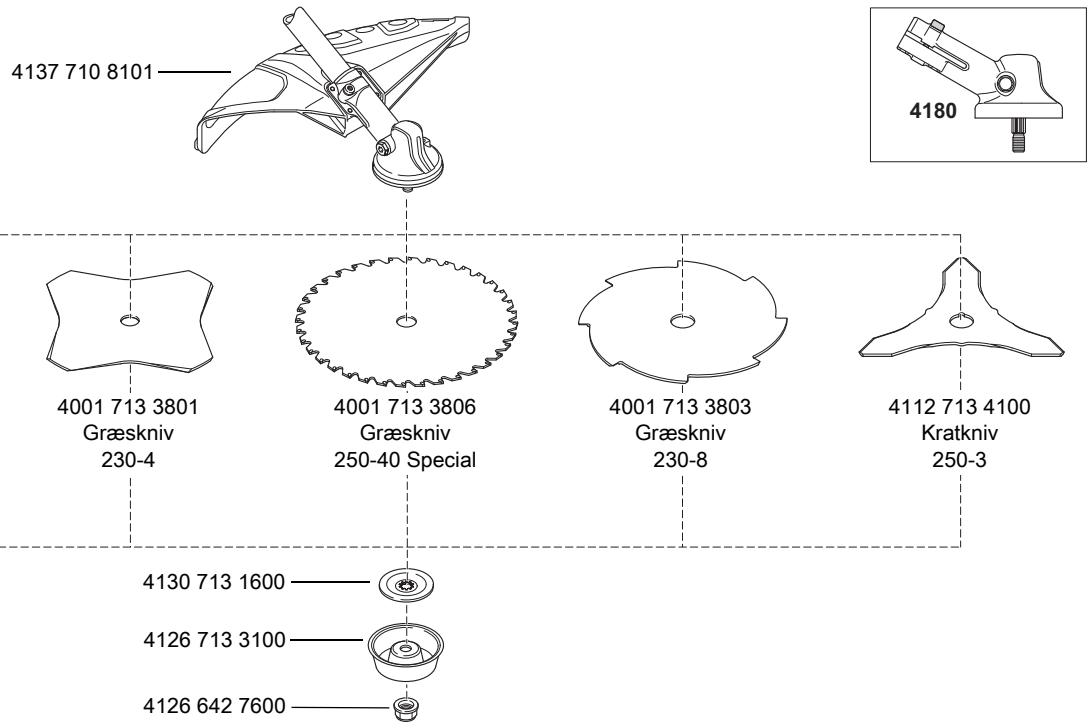

(a) fra 2017

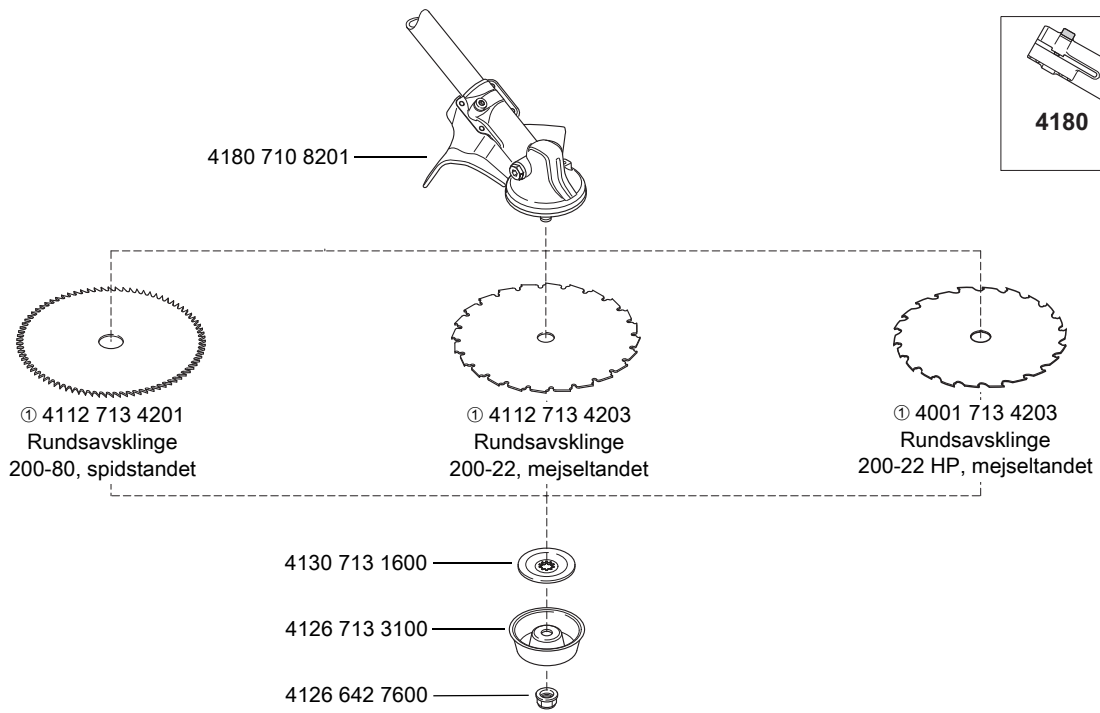

0000-GXX-5700-A0

① Ikke tilladt på trimmere med specialhåndtag

(a) fra 1996 indtil 2017 (b) indtil 2017 (c) fra 2006 (d) FS 100 RX: side 59

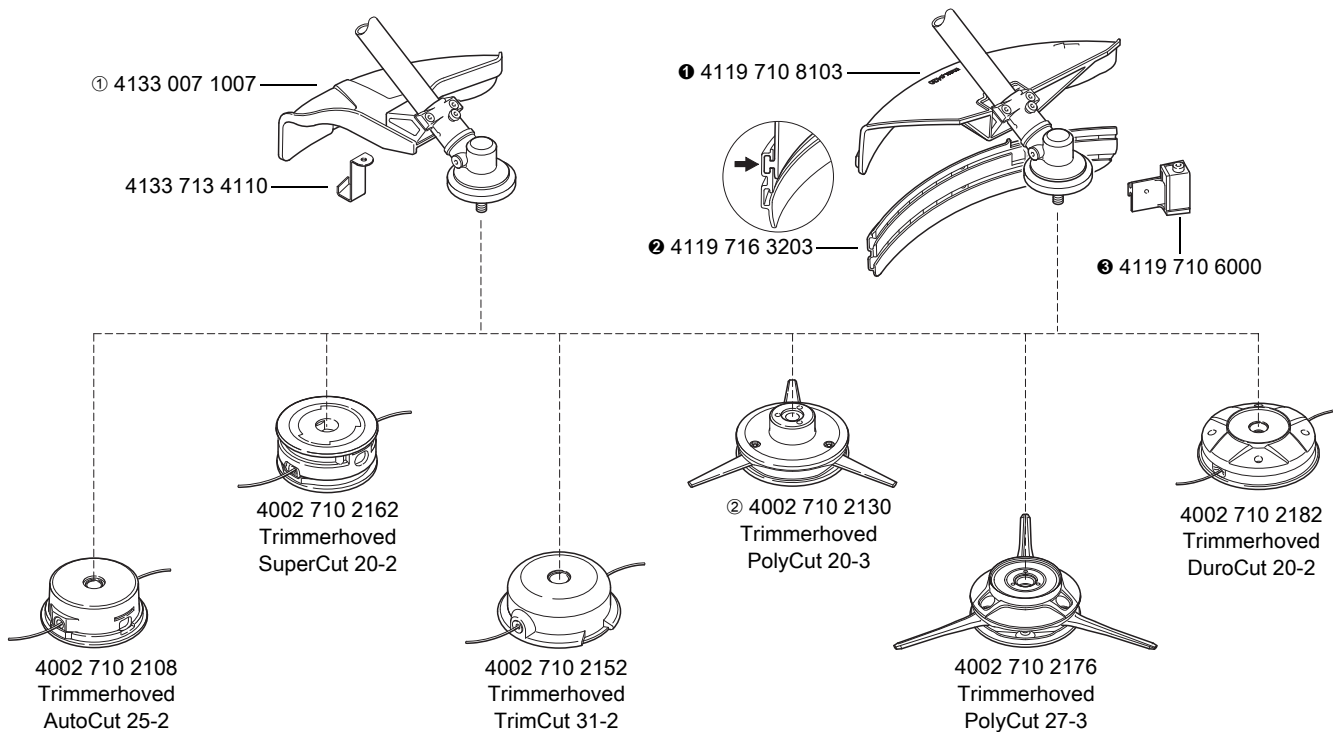

0000-GXX-5732-A0

① Kun tilladt i AUS, NZ: 4133 007 1008

② Leveres ikke længere

① + ② + ③ = 4119 007 1027

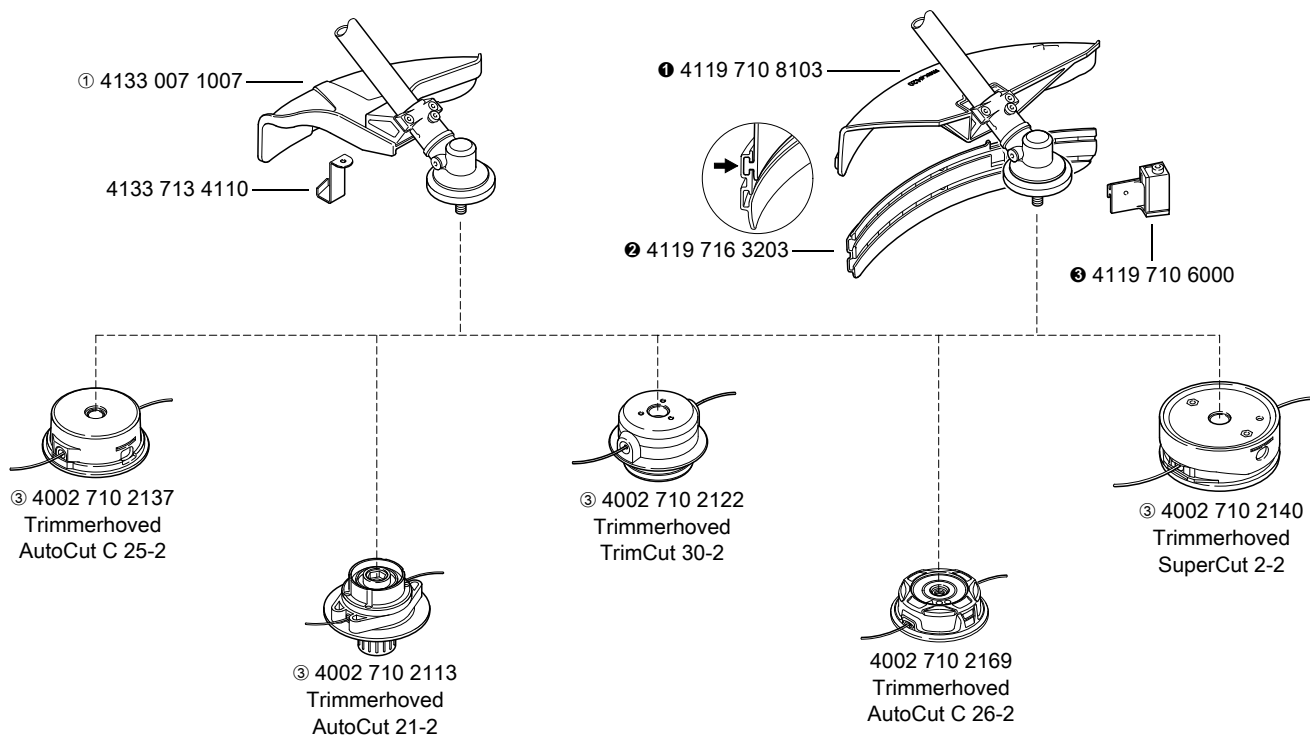

0000-GXX-3449-A0

① Kun tilladt i AUS, NZ: 4133 007 1008

① + ② + ③ = 4119 007 1027

② Specialtilbehør

③ Leveres ikke længere

(a) fra 1996 indtil 2017 (b) indtil 2017 (c) fra 2006 (d) FS 100 RX: side 59

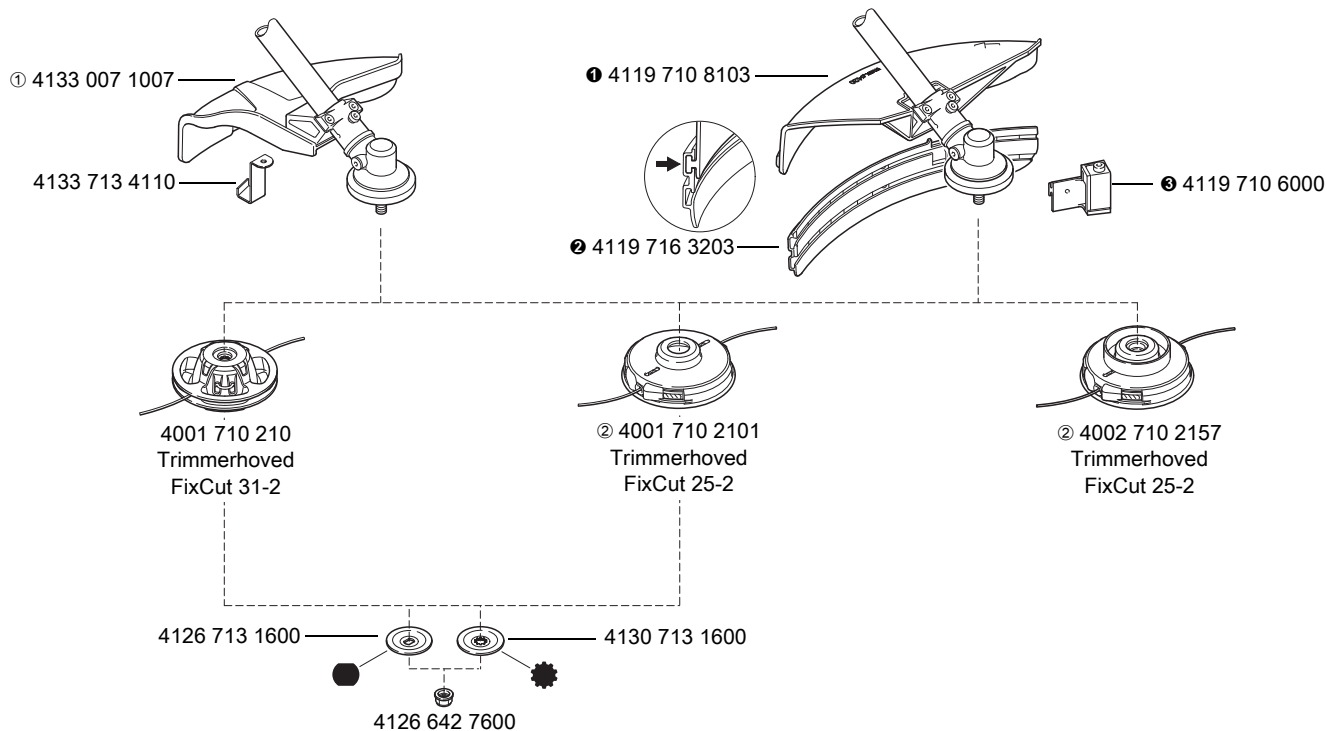

0000-GXX-5797-A0

① Kun tilladt i AUS, NZ: 4133 007 1008

② Leveres ikke længere

❶ + ❷ + ❸ = 4119 007 1027

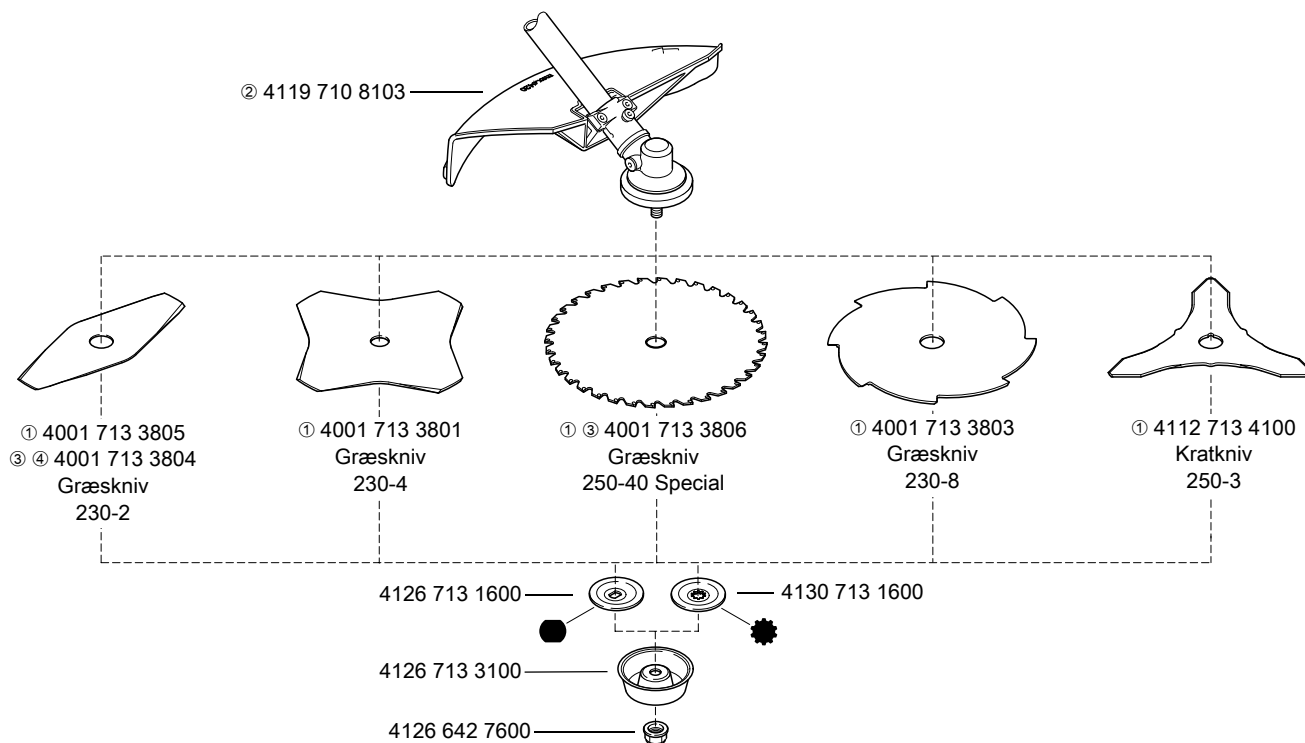

681KT851 KN

① Ikke tilladt til FS 85 RX, 100 RX, 110 RX

② Beskyttelse til AUS, NZ, se billedet med "AUS, NZ"

③ Ikke tilladt til FS 65-4

❷ Leveres ikke længere

(a) fra 1996 indtil 2017 (b) indtil 2017 (c) fra 2006 (d) FS 100 RX: side 59

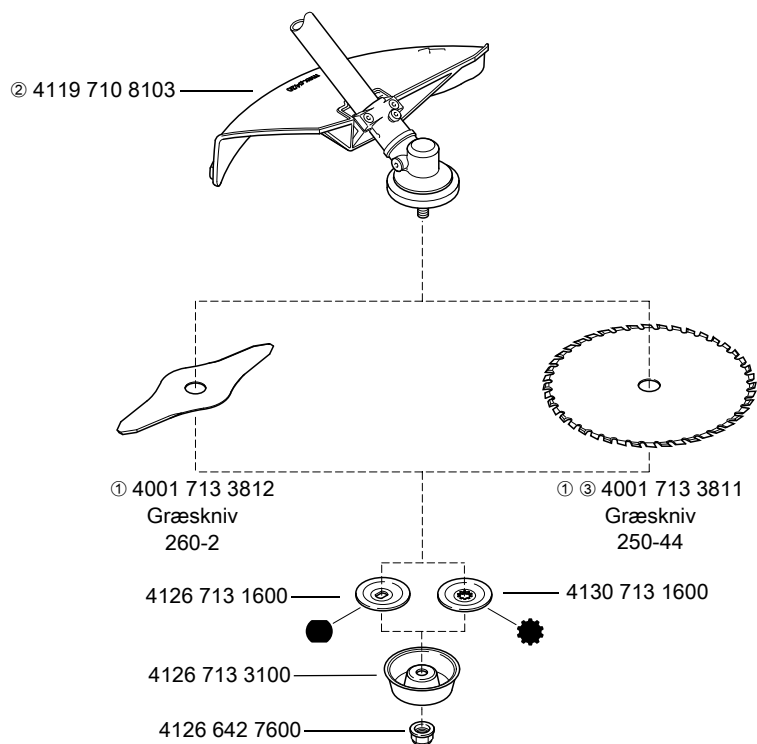

681KT1064 KN

- ① Ikke tilladt til FS 85 RX, 100 RX, 110 RX
- ② Beskyttelse til AUS, NZ, se billedet med "AUS, NZ"
- ③ Ikke tilladt til FS 65-4

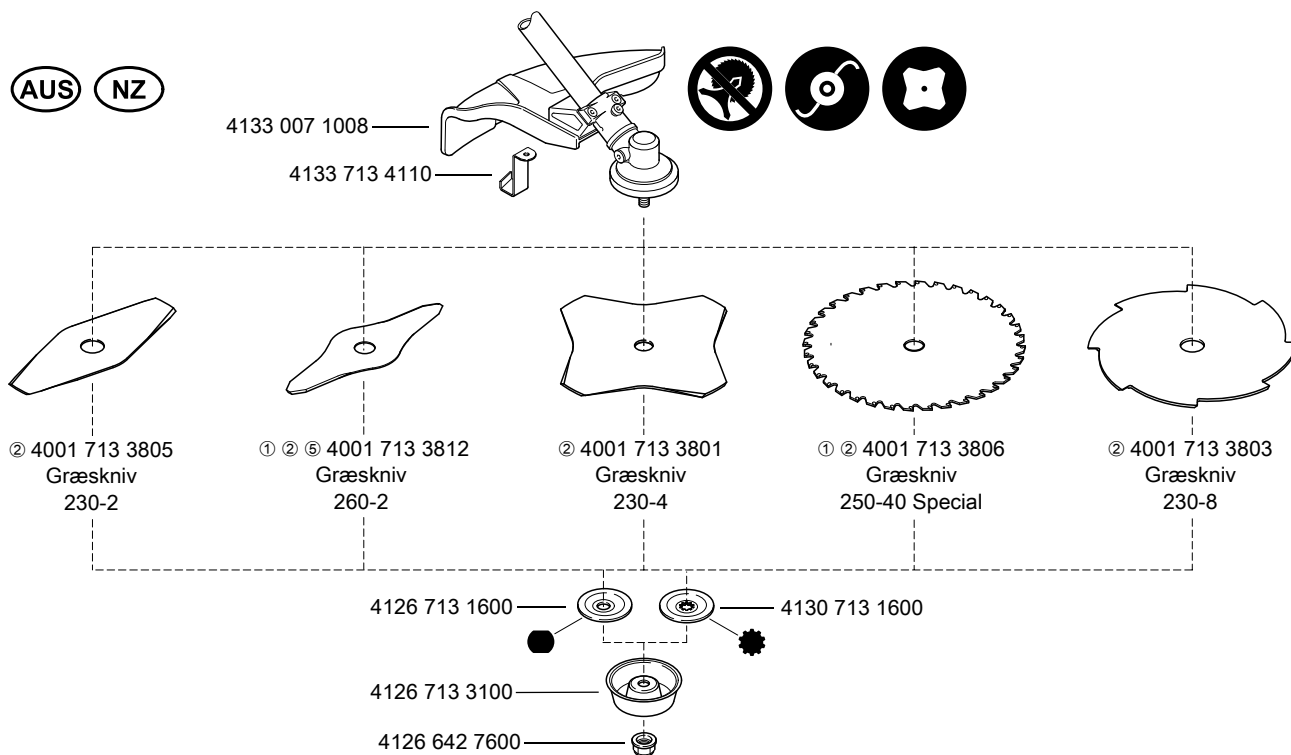

681KT1065KN

- ① Ikke tilladt til FS 65-4
- ② Ikke tilladt til FS 85 RX, 100 RX, 110 RX

(a) fra 1996 indtil 2017 (b) indtil 2017 (c) fra 2006 (d) FS 100 RX: side 59

AUS NZ

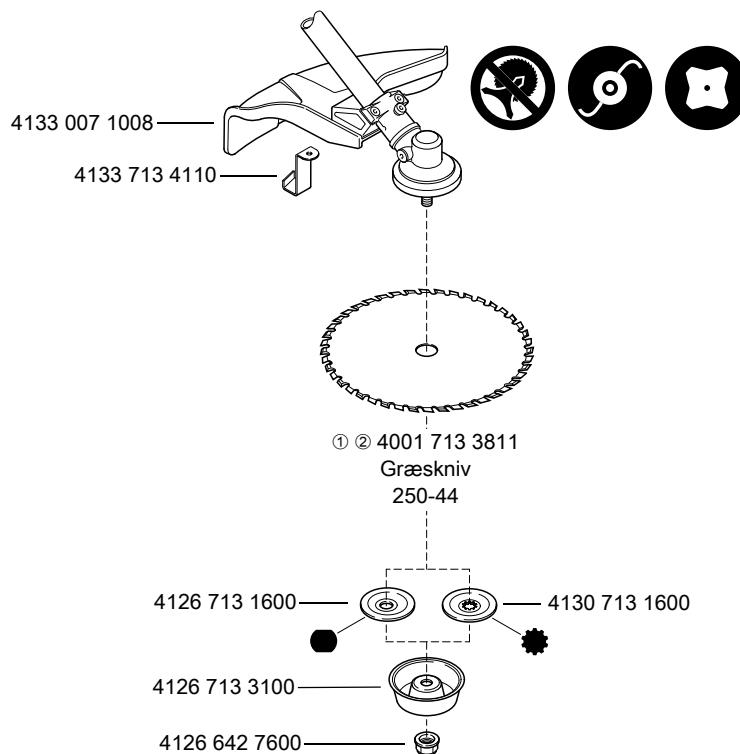

681KT1117 KN

① Ikke tilladt til FS 65-4

② Ikke tilladt til FS 85 RX, 100 RX, 110 RX

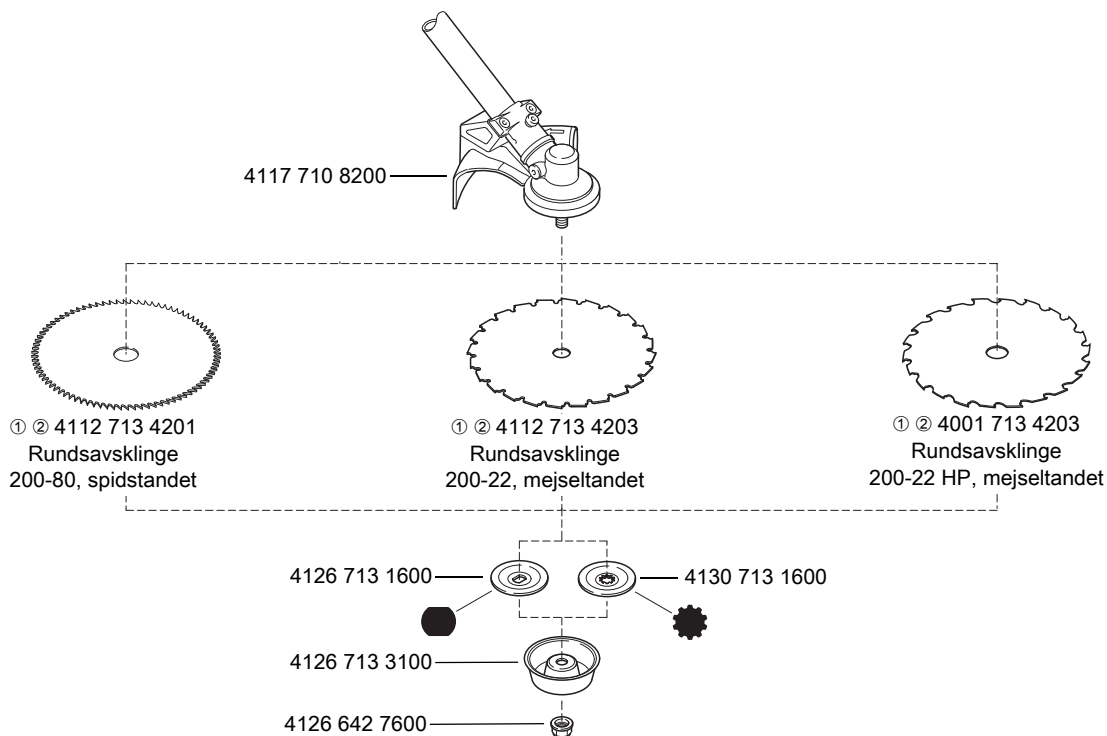

3000-GXX-5698-A0

① Ikke tilladt til FS 85 RX, 100 RX, 110 RX

② Ikke tilladt på trimmere med specialhåndtag

(a) fra maskinnr. X 14 821 681

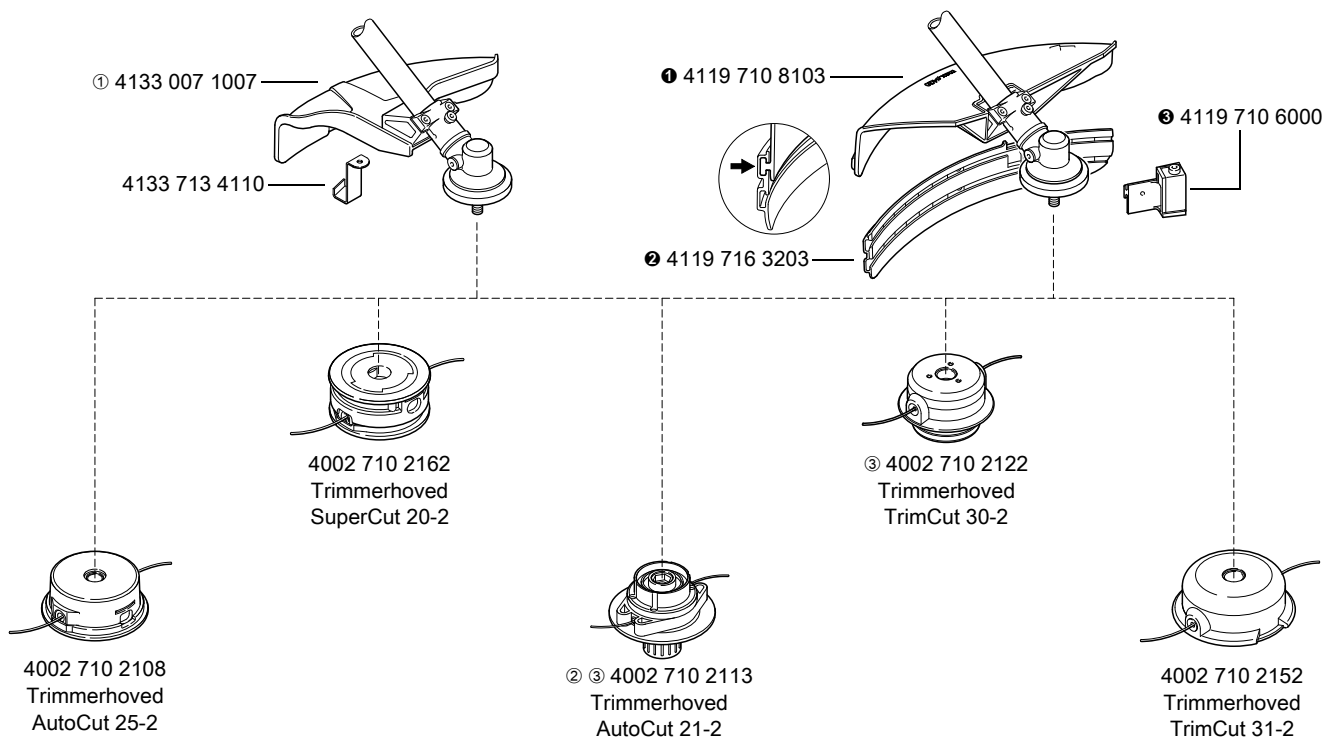

681KT802 KN

① Kun tilladt i AUS, NZ: 4133 007 1008

① + ② + ③ = 4119 007 1027

② Ikke tilladt til FS 81, 86, 88, 106, 108

③ Leveres ikke længere

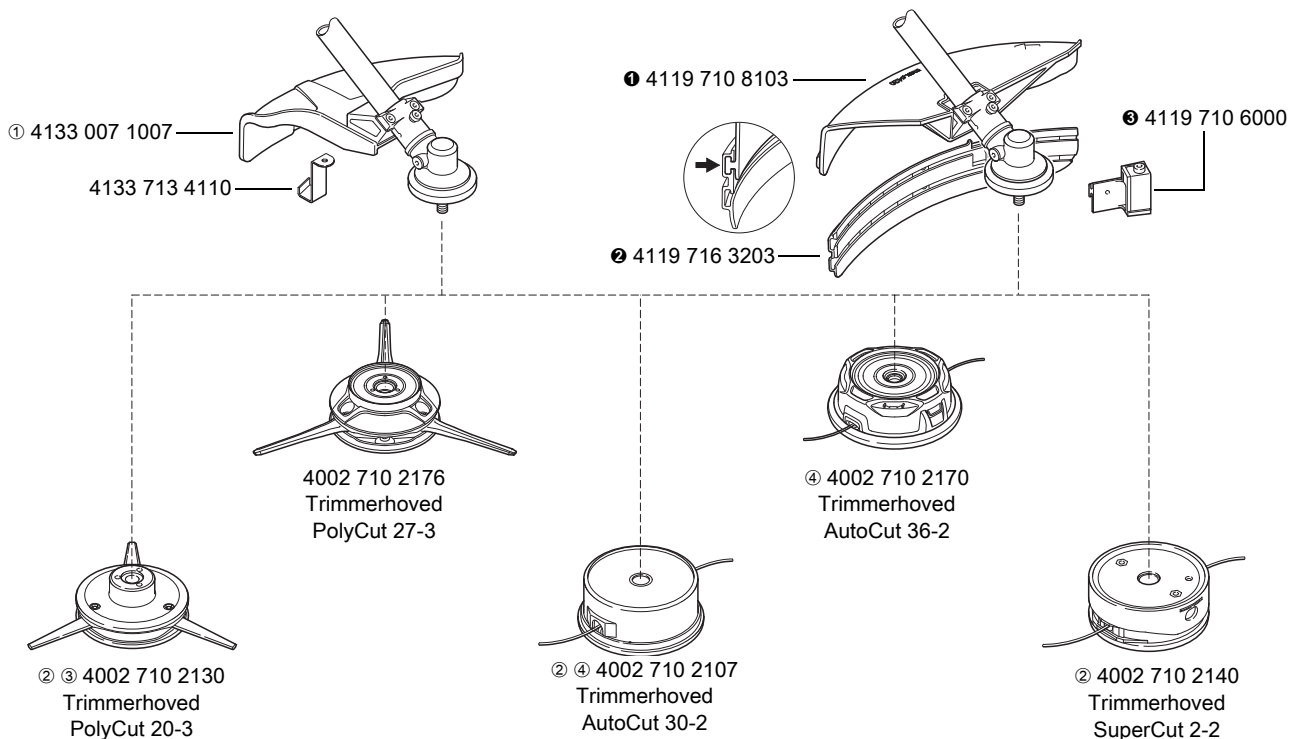

3000-GXX-5734-A0

① Kun tilladt i AUS, NZ: 4133 007 1008

① + ② + ③ = 4119 007 1027

② Leveres ikke længere

③ Ikke tilladt til FS 86, 88, 106, 108

④ Ikke tilladt til FS 66, 74, 76, 81

(a) fra maskinnr. X 14 821 681

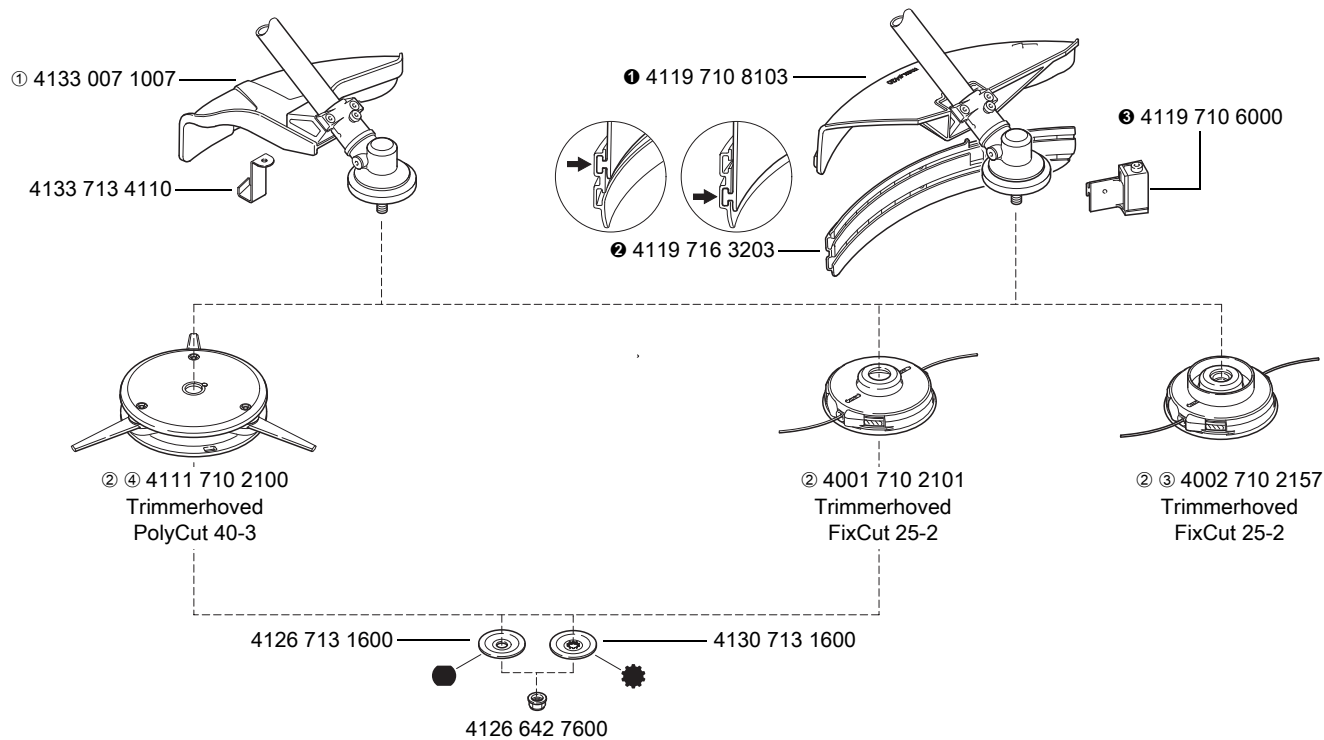

681KT519-A1

① Kun tilladt i AUS, NZ: 4133 007 1008

② Leveres ikke længere

③ Ikke tilladt til FS 66, 81, 86, 88, 106, 108

④ Ikke tilladt til FS 66, 74, 76, 81

① + ② + ③ = 4119 007 1027

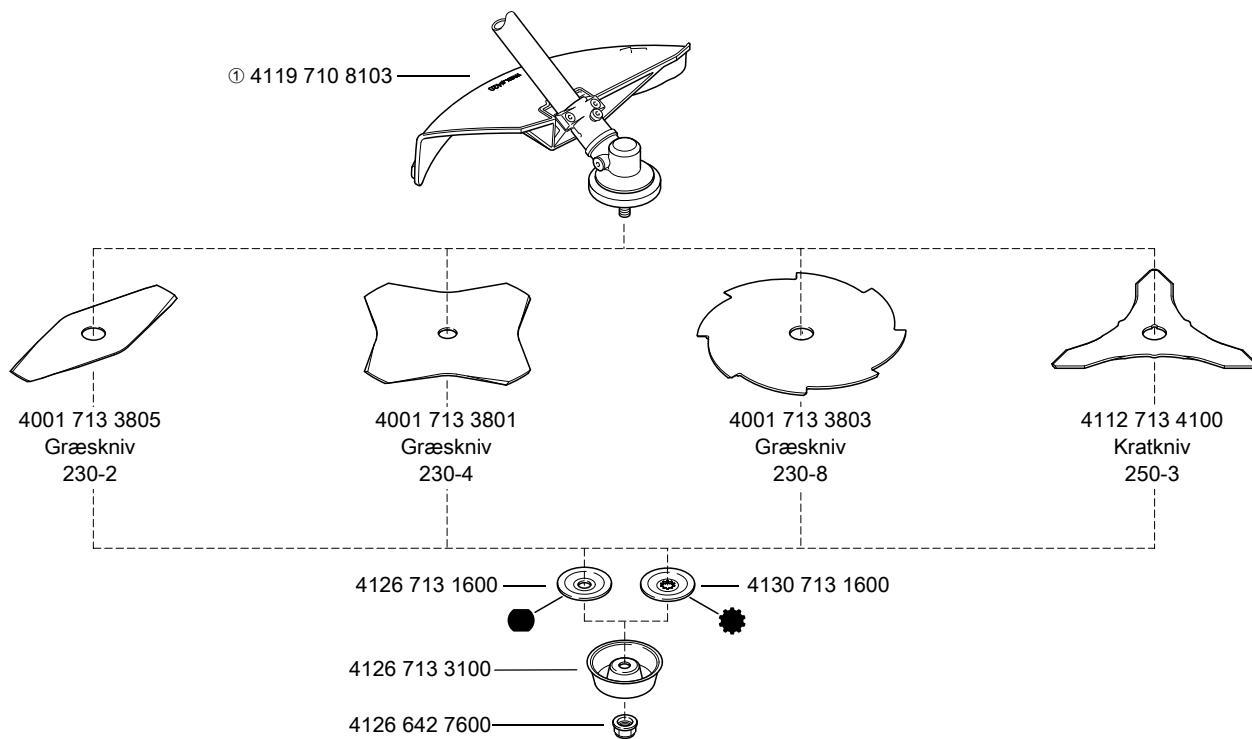

681KT520-KN

① Beskyttelse til AUS, NZ, se billedet med "AUS, NZ"

(a) fra maskinnr. X 14 821 681

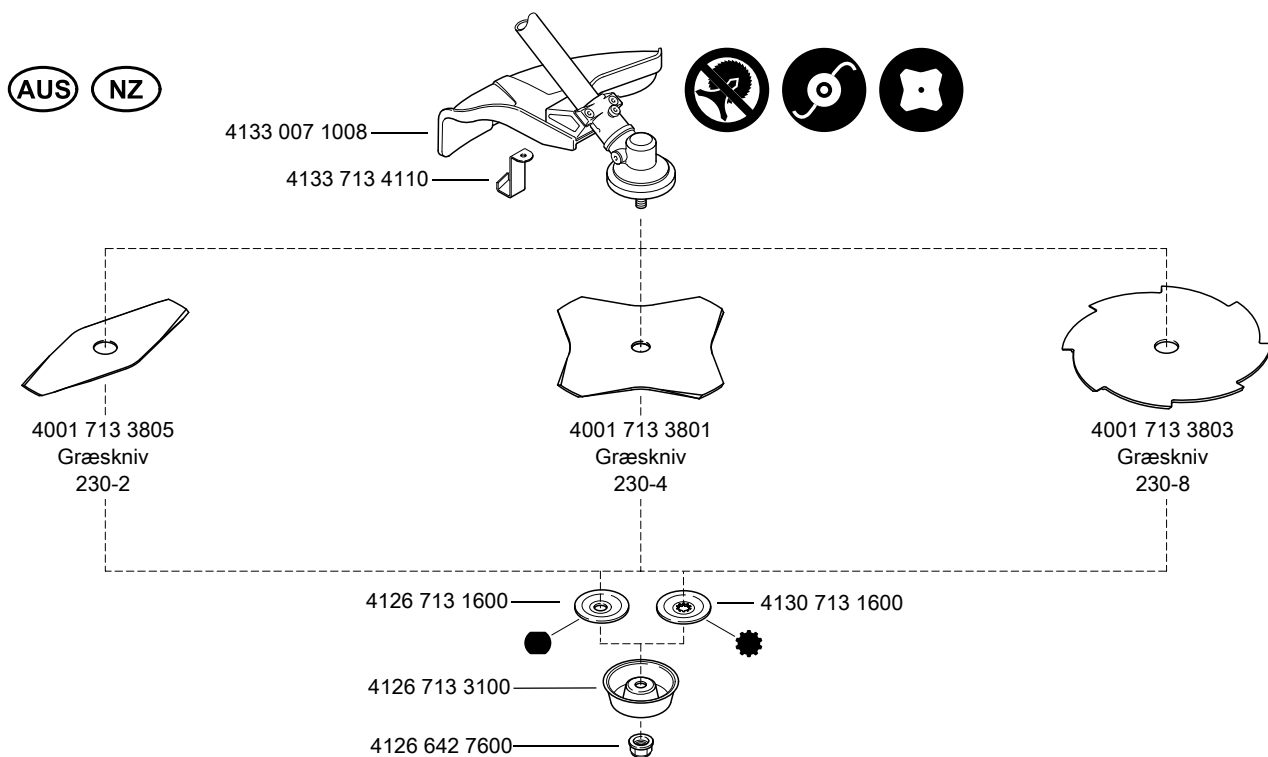

681KT864 KN

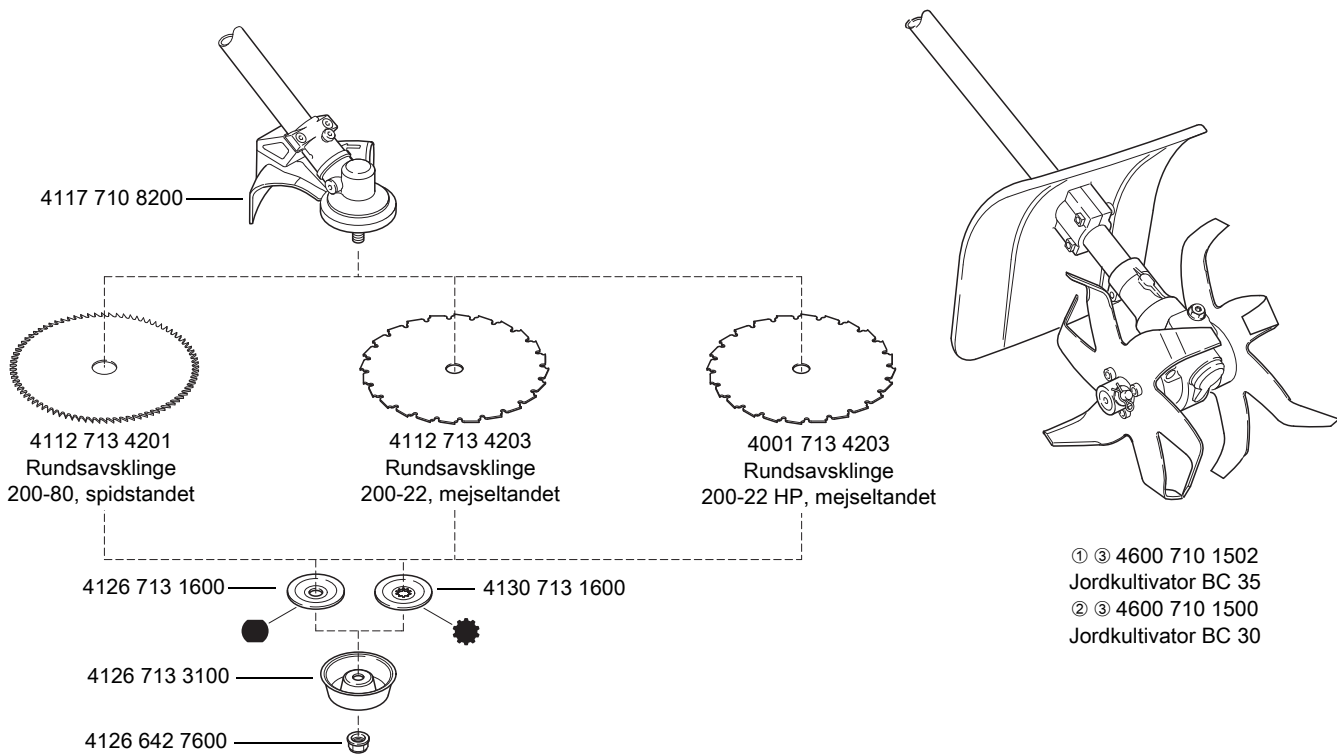

381KT521-A1

① Ikke tilladt til FS 66

② Ikke tilladt til FS 76, 81, 86, 88, 106, 108

③ Leveres ikke længere

④ Ikke tilladt på trimmere med specialhåndtag

(a) til maskinnr. X 14 821 680

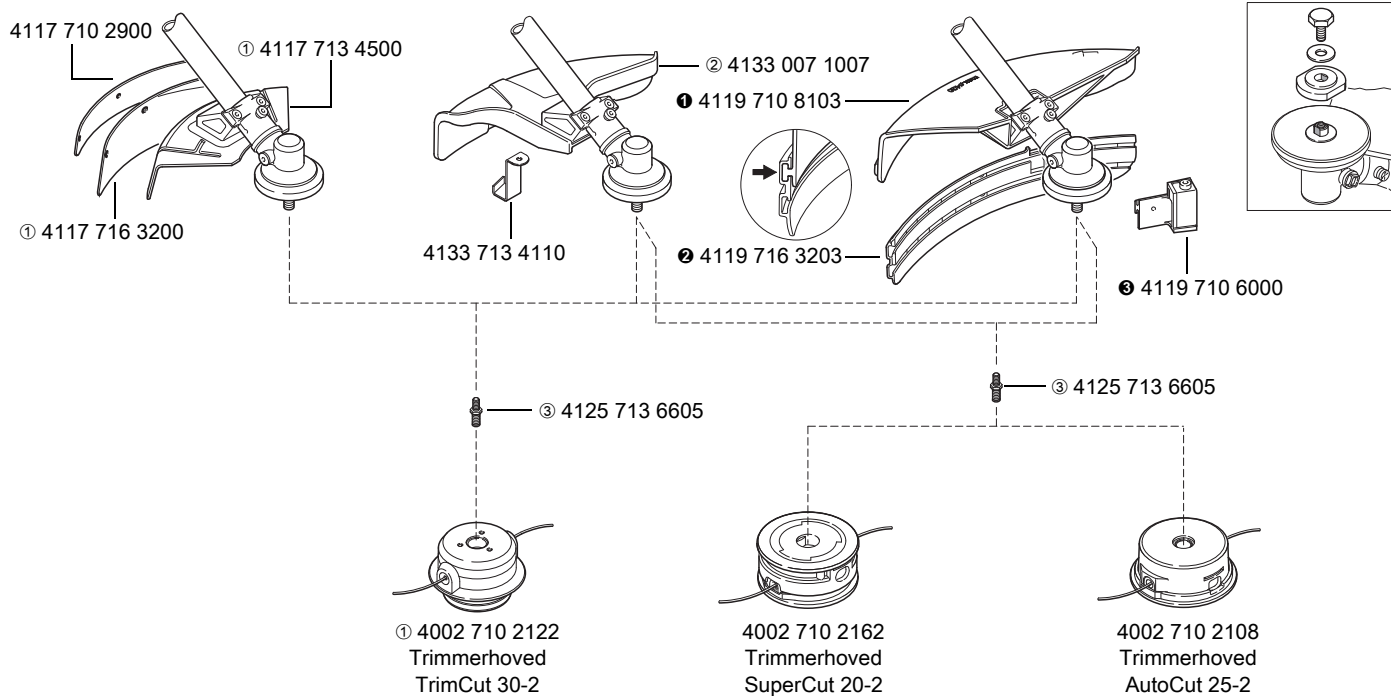

681KT951-A1

① Leveres ikke længere

① + ② + ③ = 4119 007 1027

② Kun tilladt i AUS, NZ: 4133 007 1008

③ Specialtilbehør

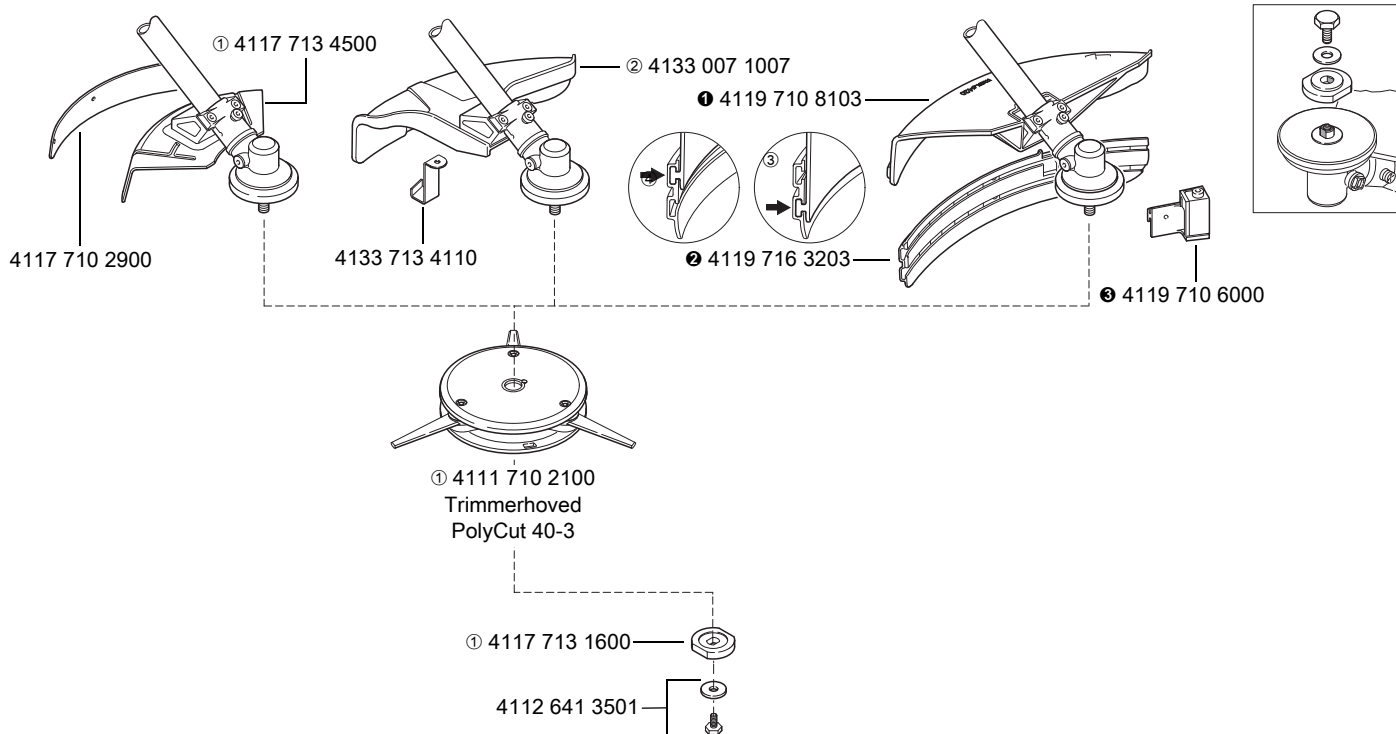

381KT523-A1

① Leveres ikke længere

② Kun tilladt i AUS, NZ: 4133 007 1008

① + ② + ③ = 4119 007 1027

(a) til maskinnr. X 14 821 680

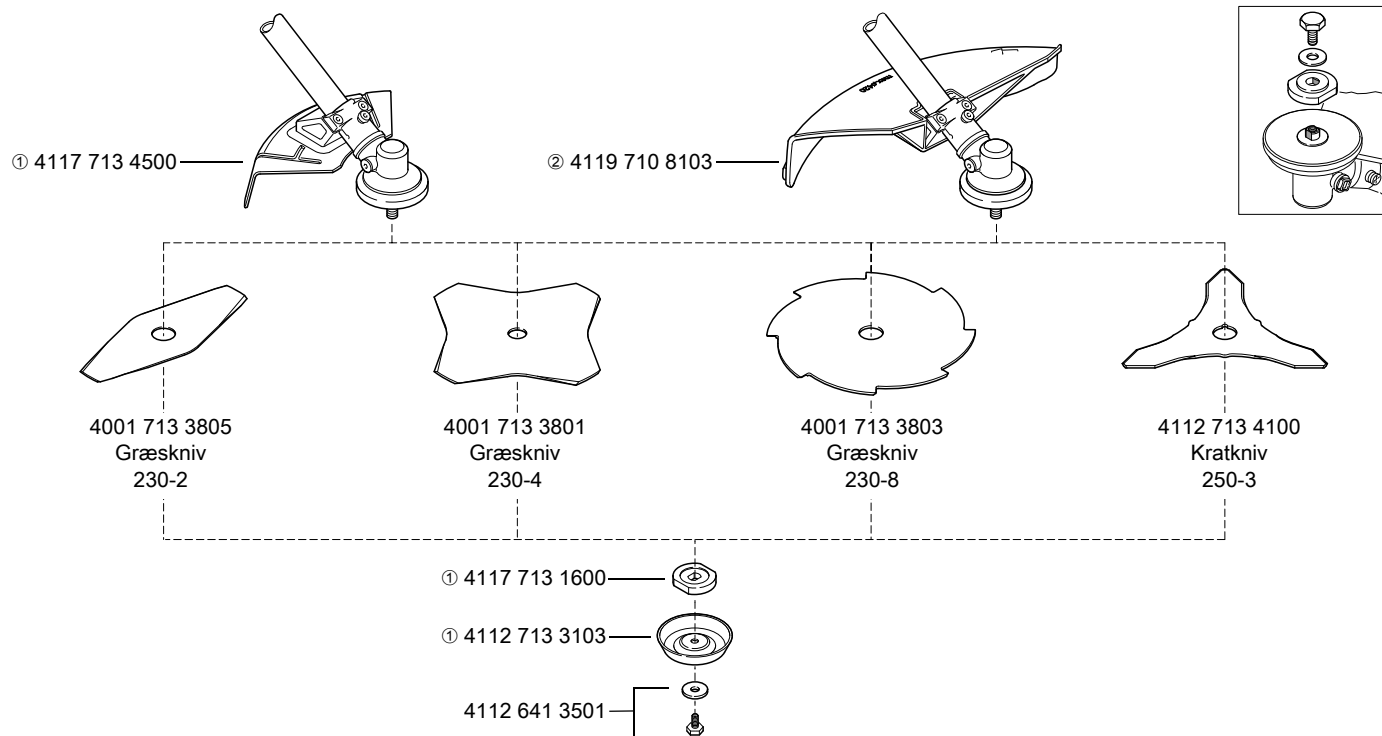

68 1KT524 KN

① Leveres ikke længere

② Beskyttelse til AUS, NZ, se billedet med "AUS, NZ"

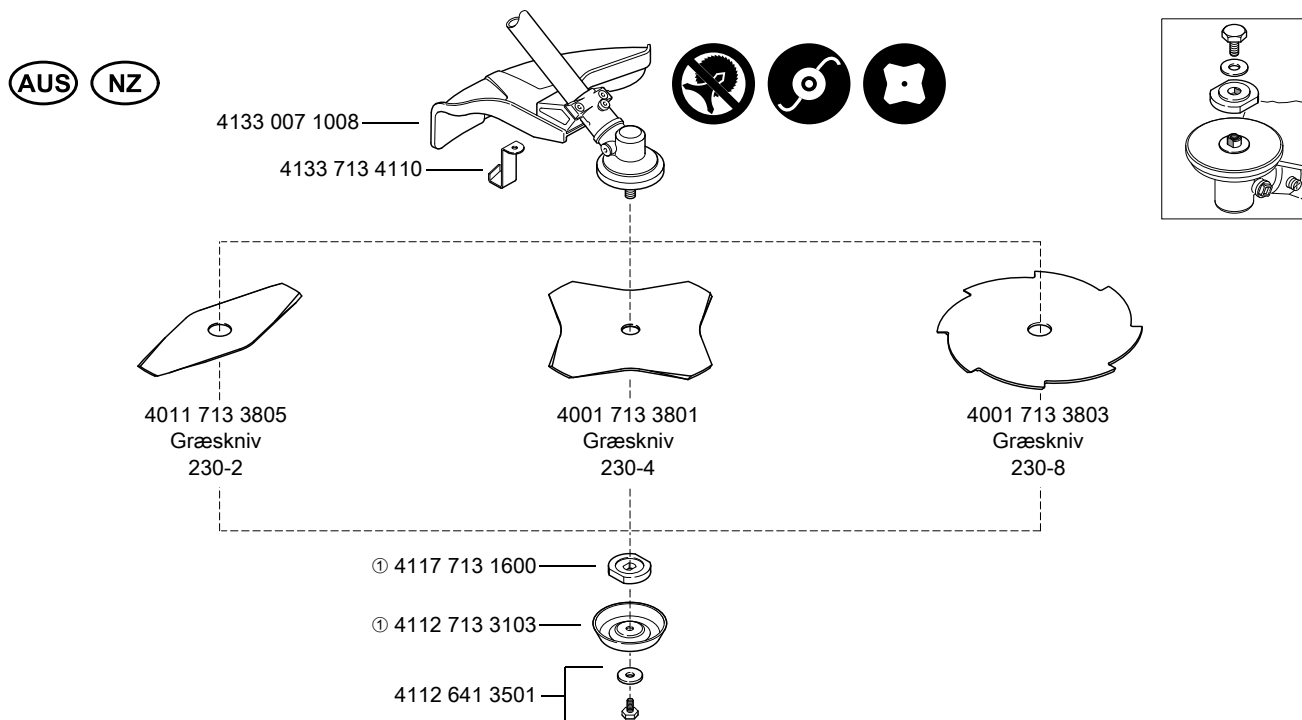

68 1KT535 KN

① Leveres ikke længere

(a) til maskinnr. X 14 821 680

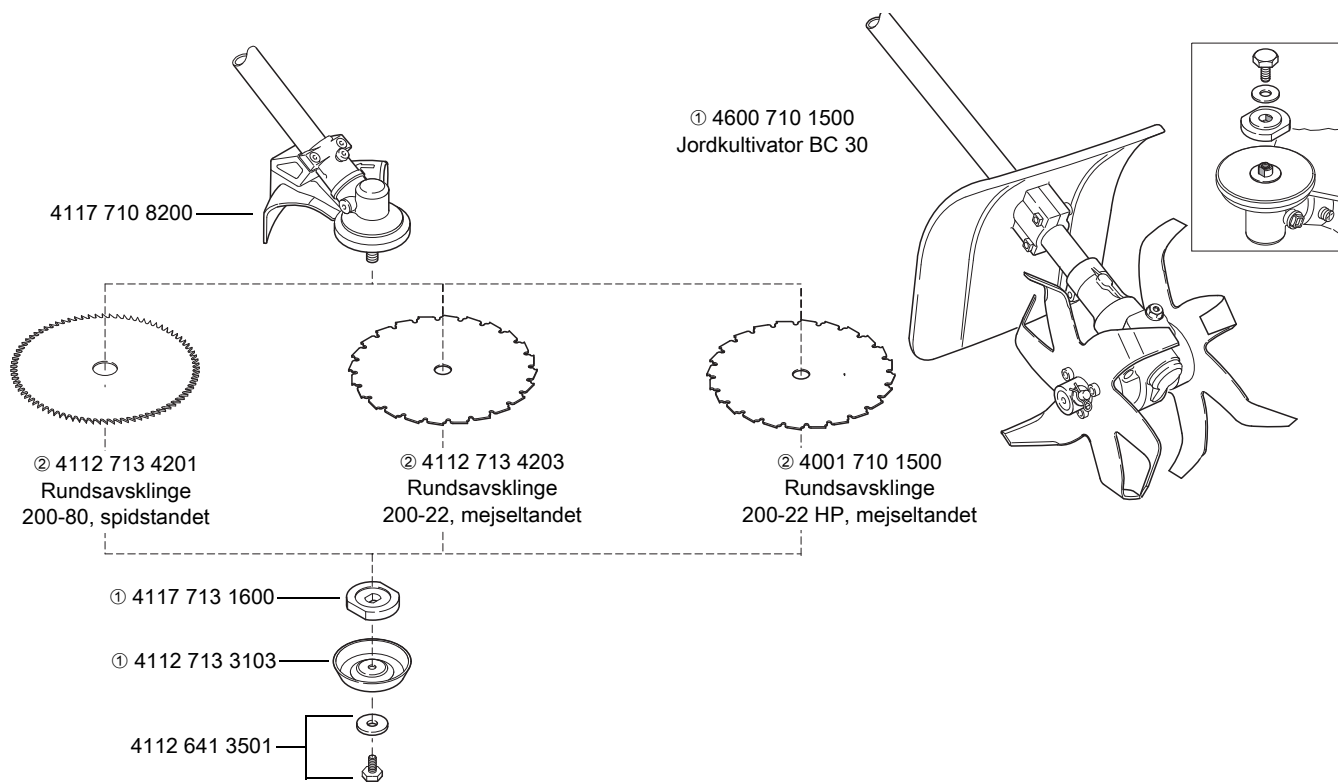

681KT525-A1

① Leveres ikke længere

② Ikke tilladt på trimmere med specialhåndtag

(a) FS 111 RX: side 60

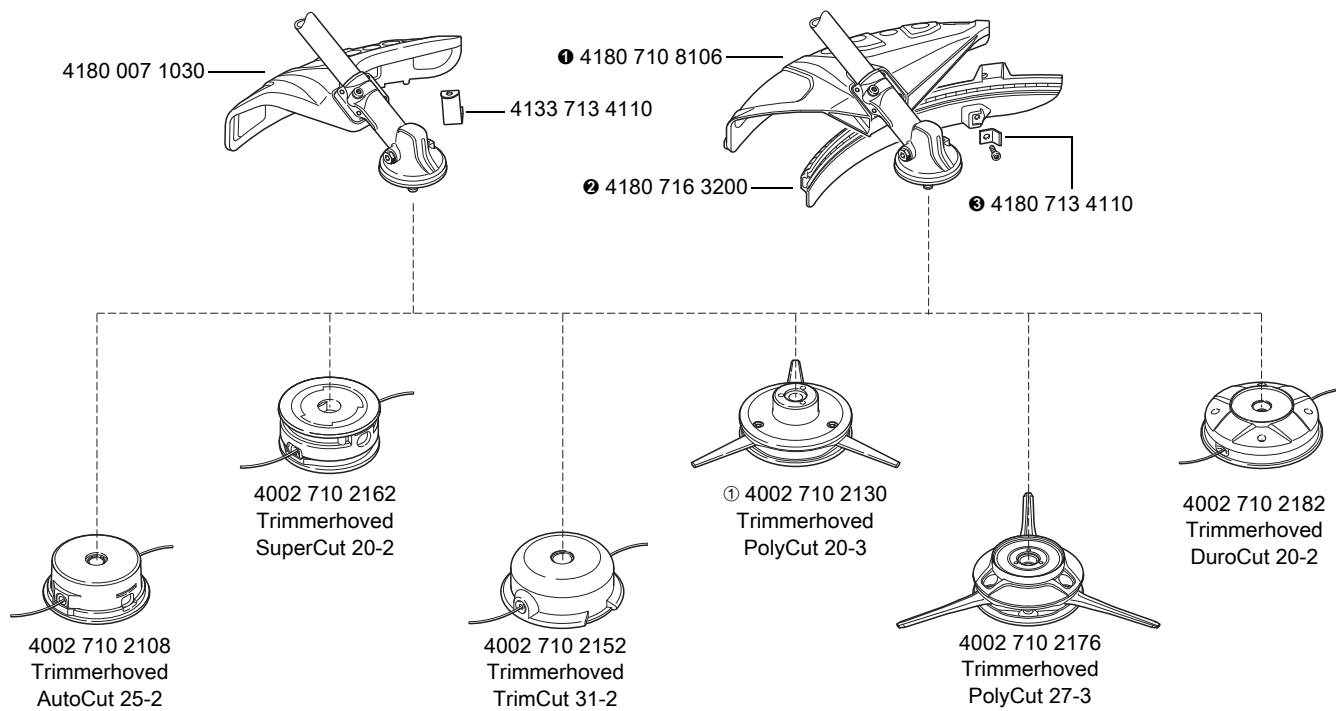

0000-GXX-5735-A0

① Leveres ikke længere

① + ② + ③ = 4180 007 1028

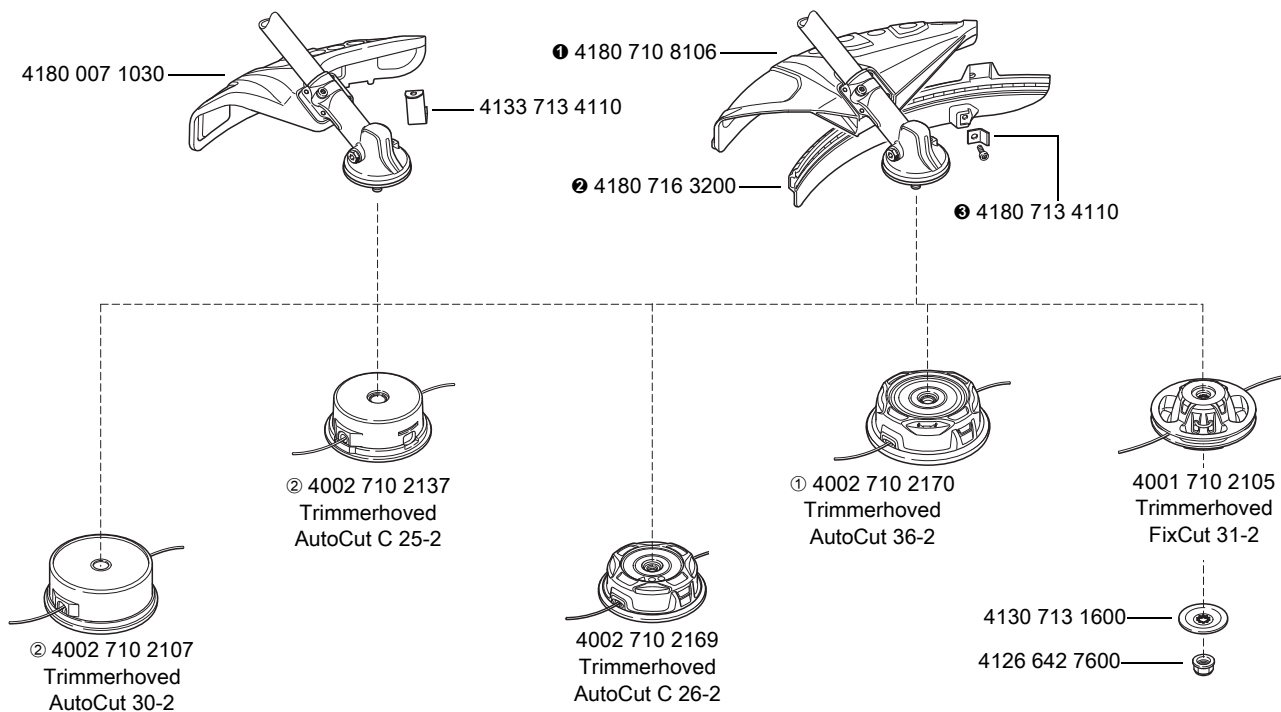

0000-GXX-5701-A0

① Ikke tilladt til FS 89

② Leveres ikke længere

① + ② + ③ = 4180 007 1028

(a) FS 111 RX: side 60

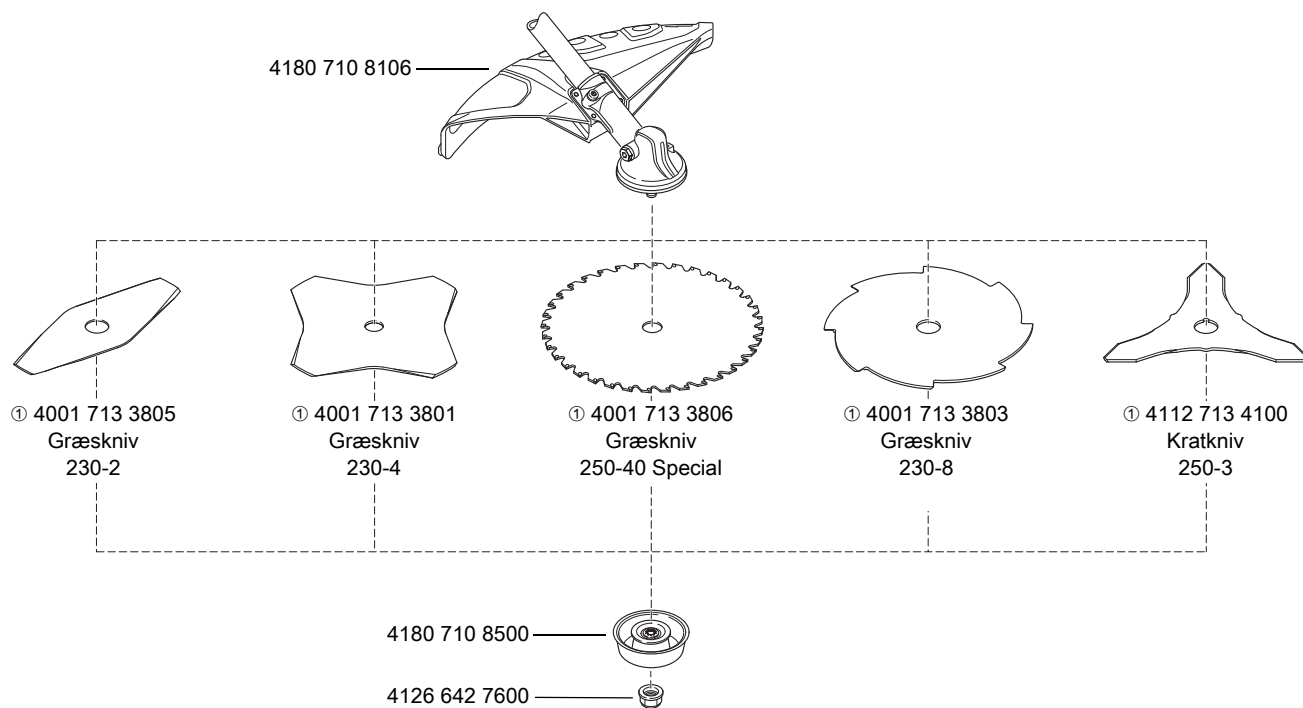

0000-GXX-3624-A0

① Ikke tilladt til FS 111 RX

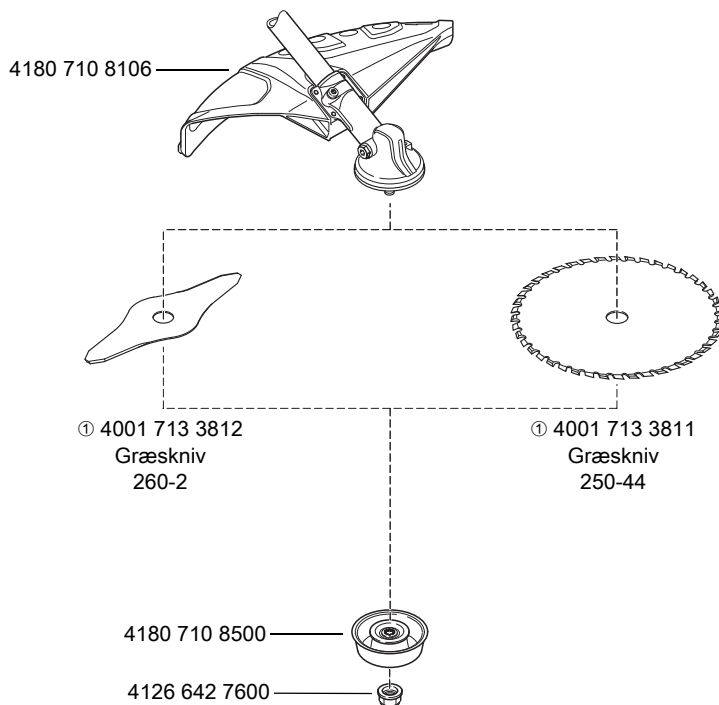

0000-GXX-3625-A0

① Ikke tilladt til FS 111 RX

(a) FS 111 RX: side 60

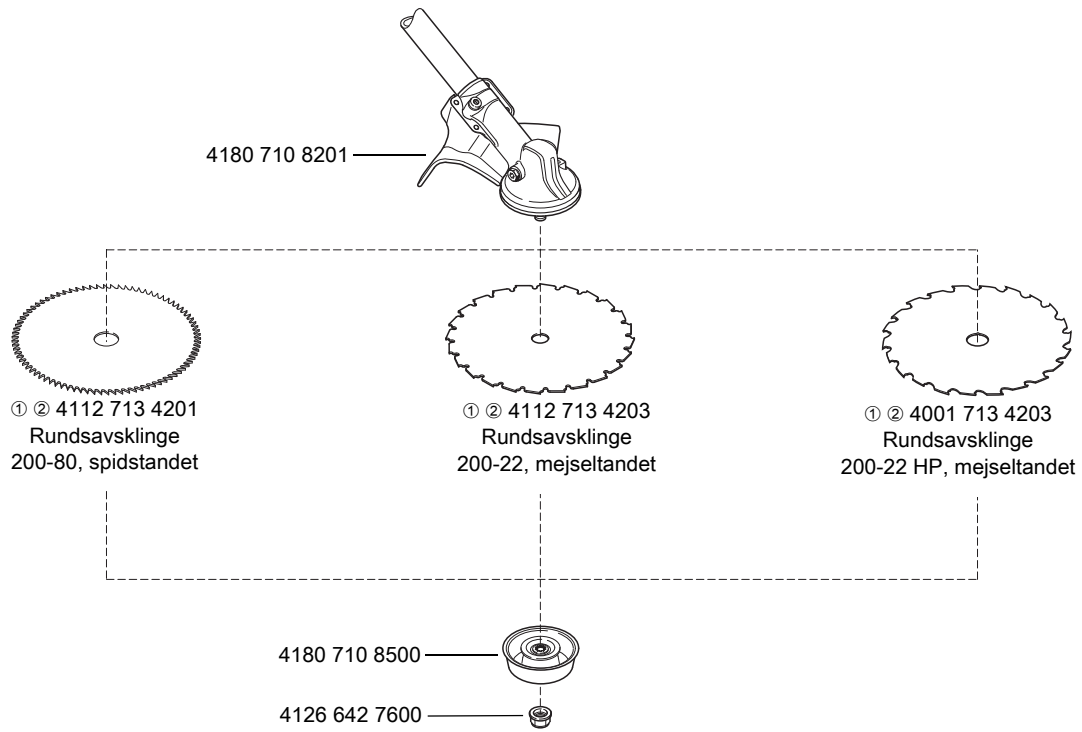

0000-GXX-5723-A0

① Ikke tilladt til FS 111 RX

② Ikke tilladt på trimmere med specialhåndtag

(a) fra 2018

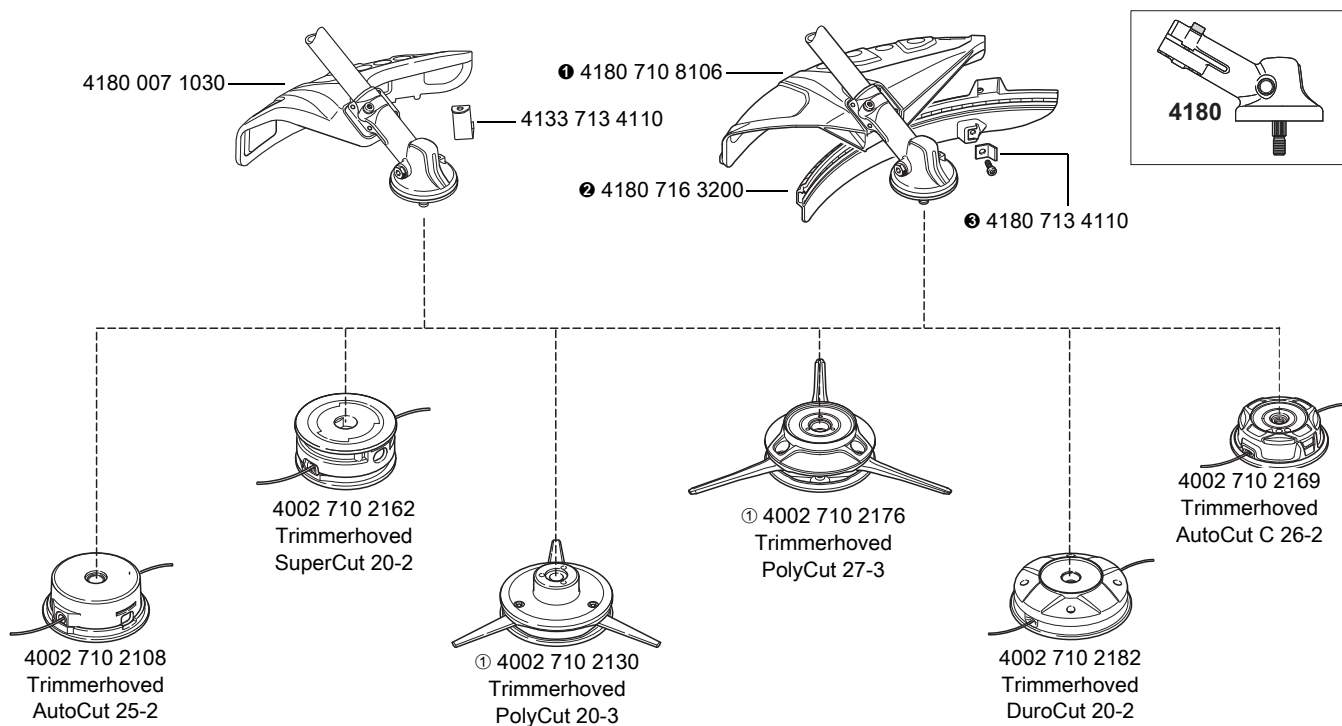

0000-GXX-5736-A0

① Leveres ikke længere

① + ② + ③ = 4180 007 1028

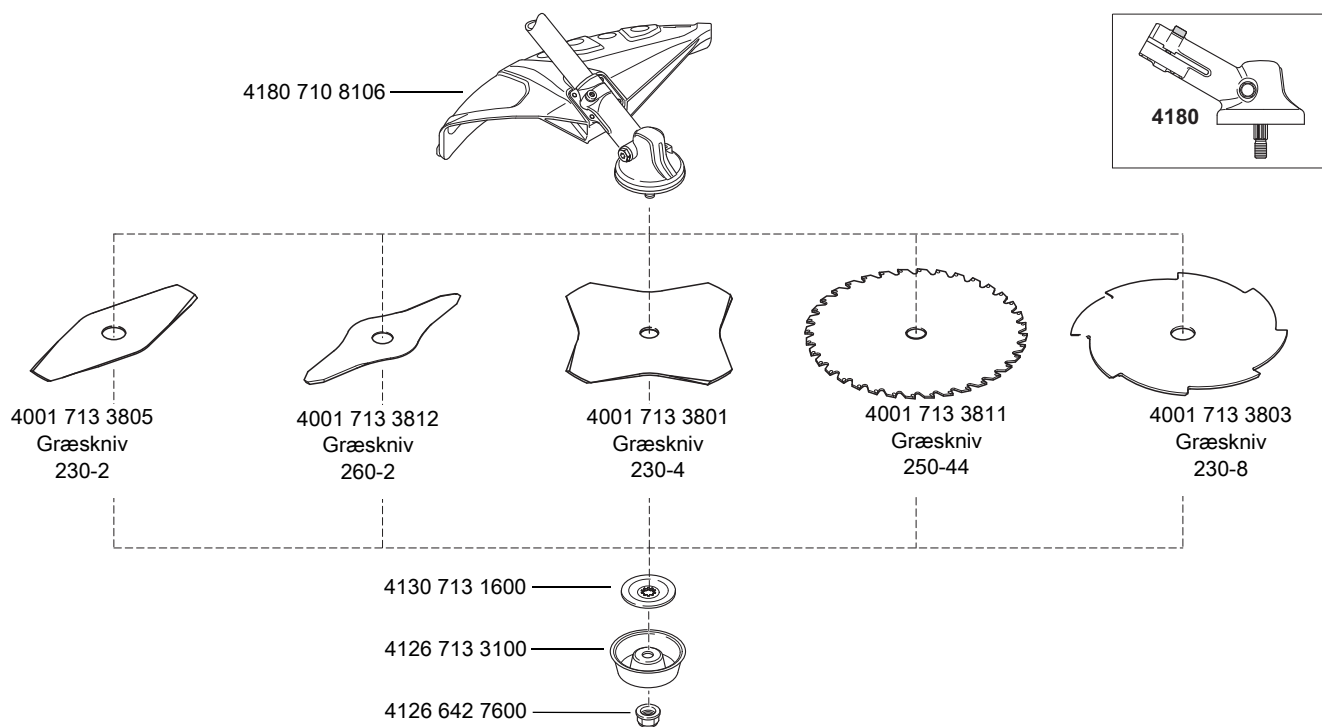

0000-GXX-6044-A0

(a) indtil 2017

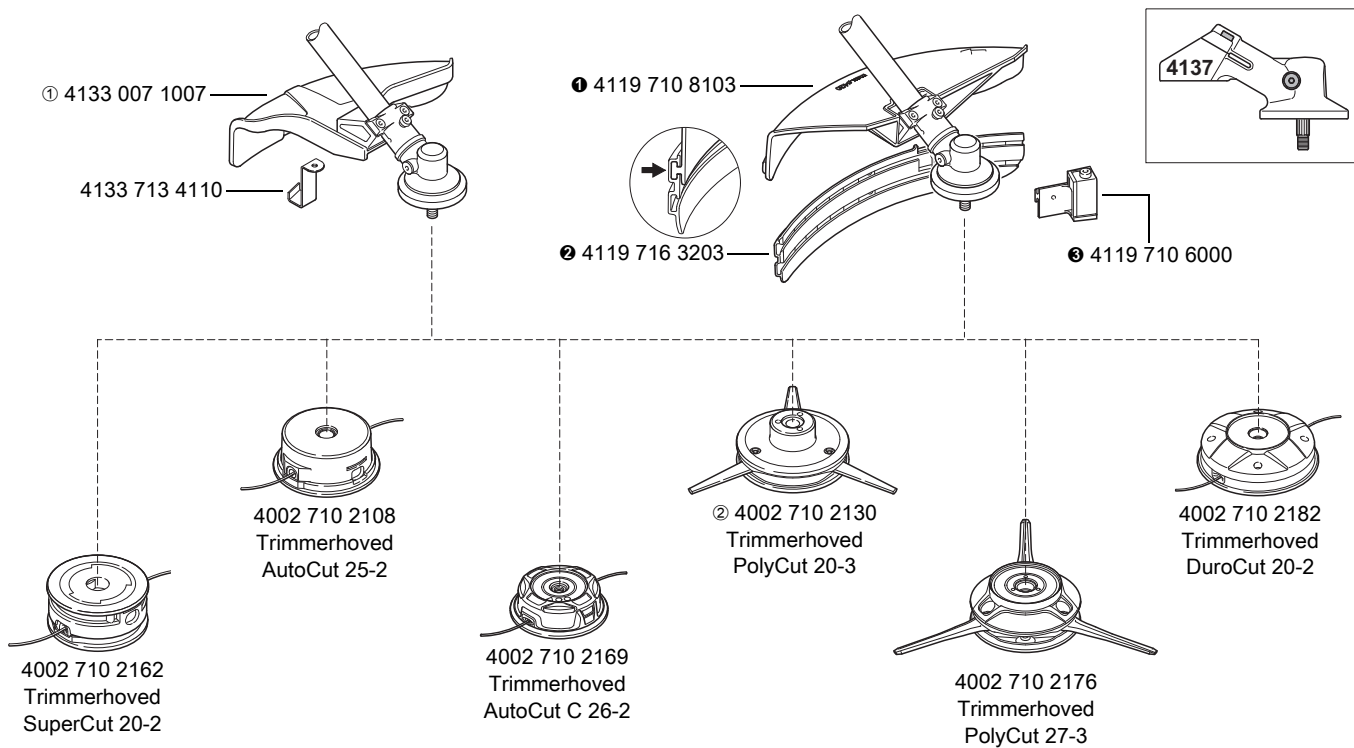

0000-GXX-5702-A0

① Kun tilladt i AUS, NZ: 4133 007 1008

② Leveres ikke længere

① + ② + ③ = 4119 007 1027

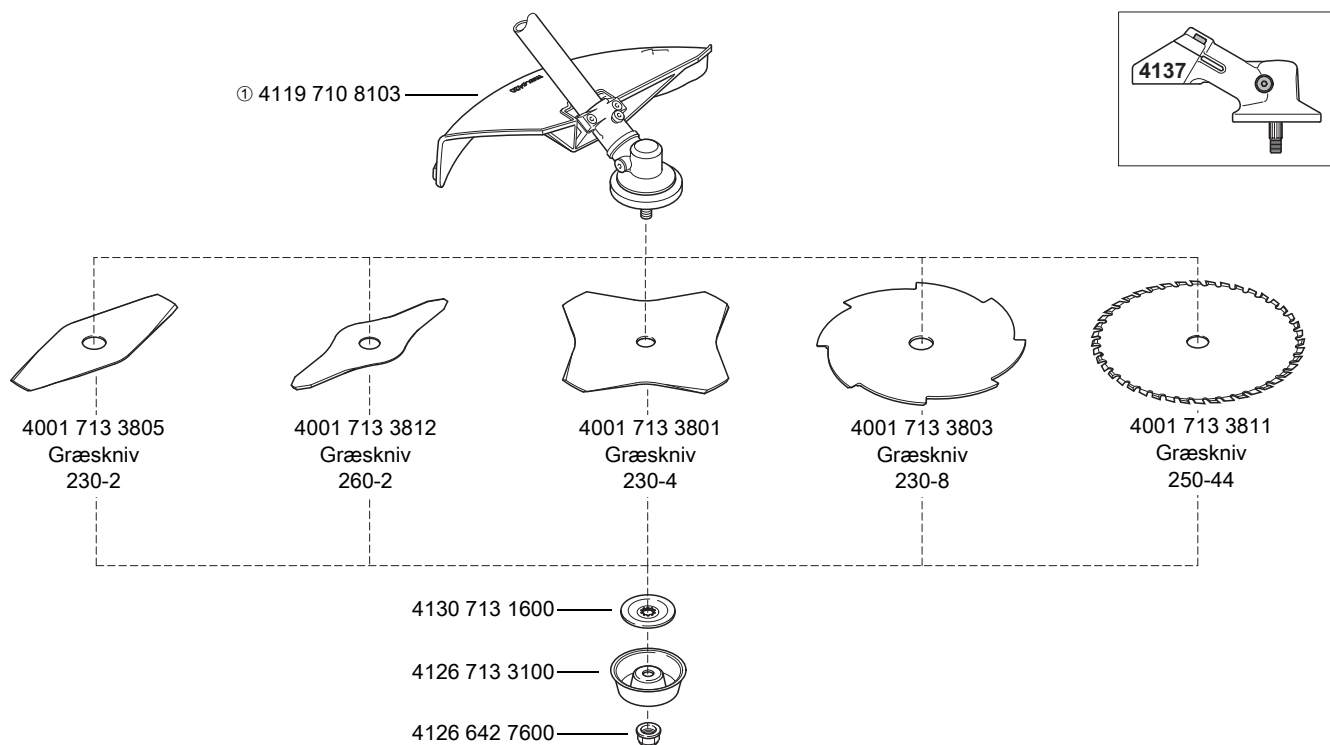

0000-GXX-5703-A0

① Beskyttelse til AUS, NZ, se billedet med "AUS, NZ"

(a) indtil 2017

AUS NZ

4133 007 1008

4133 713 4110

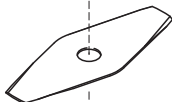
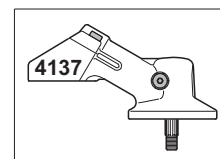
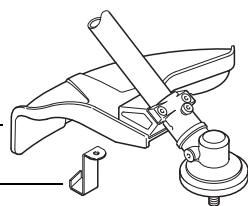

4001 713 3805
Græskniv
230-2



4001 713 3812
Græskniv
260-2



4001 713 3801
Græskniv
230-4

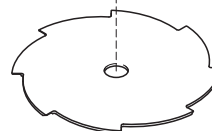

4001 713 3803
Græskniv
230-8

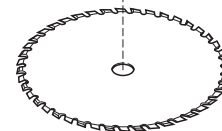

4001 713 3811
Græskniv
250-44

4130 713 1600



4126 713 3100



4126 642 7600



0000-GXX-5704-A0

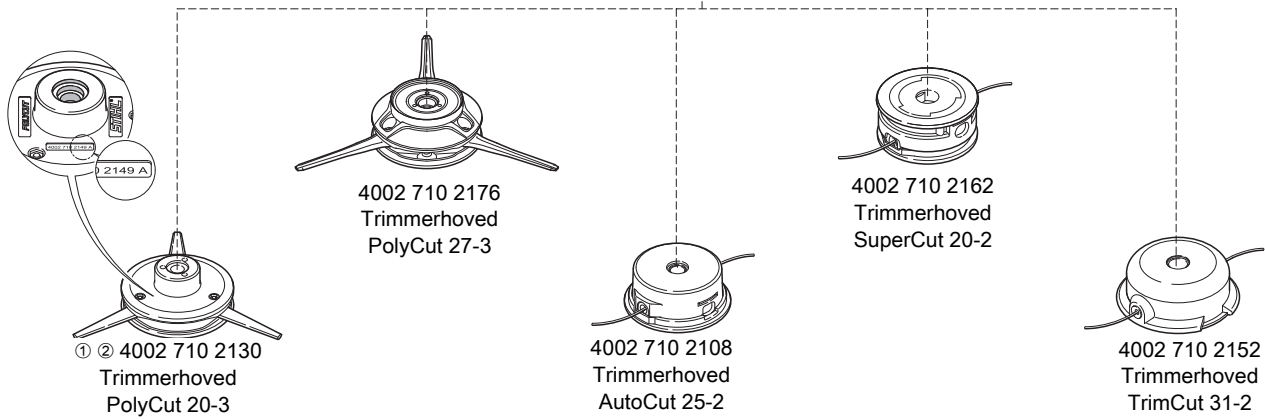
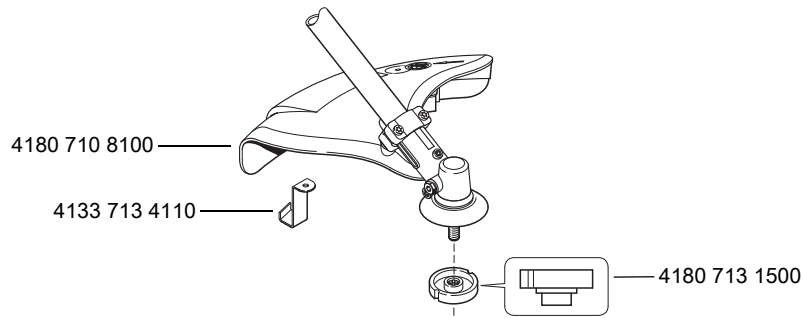

0000-GXX-5737-A0

① Kun udførelse med delnummer "2149 A" er tilladt

② Leveres ikke længere

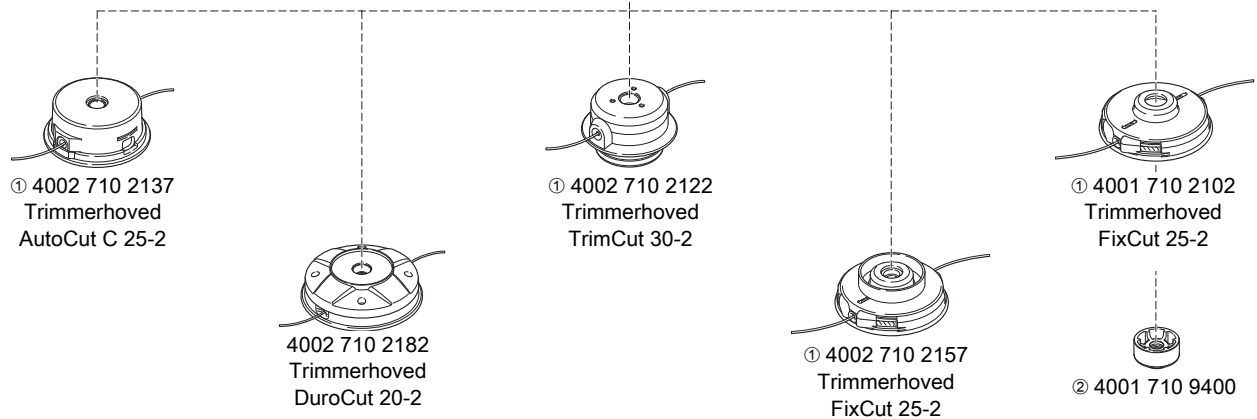
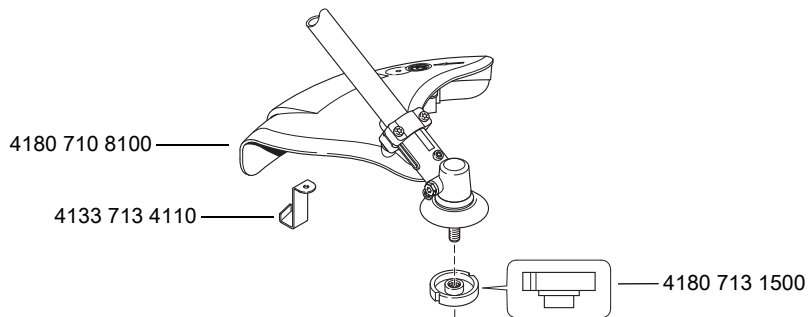

0000-GXX-3455-A0

① Leveres ikke længere

② Specialtilbehør

CDN

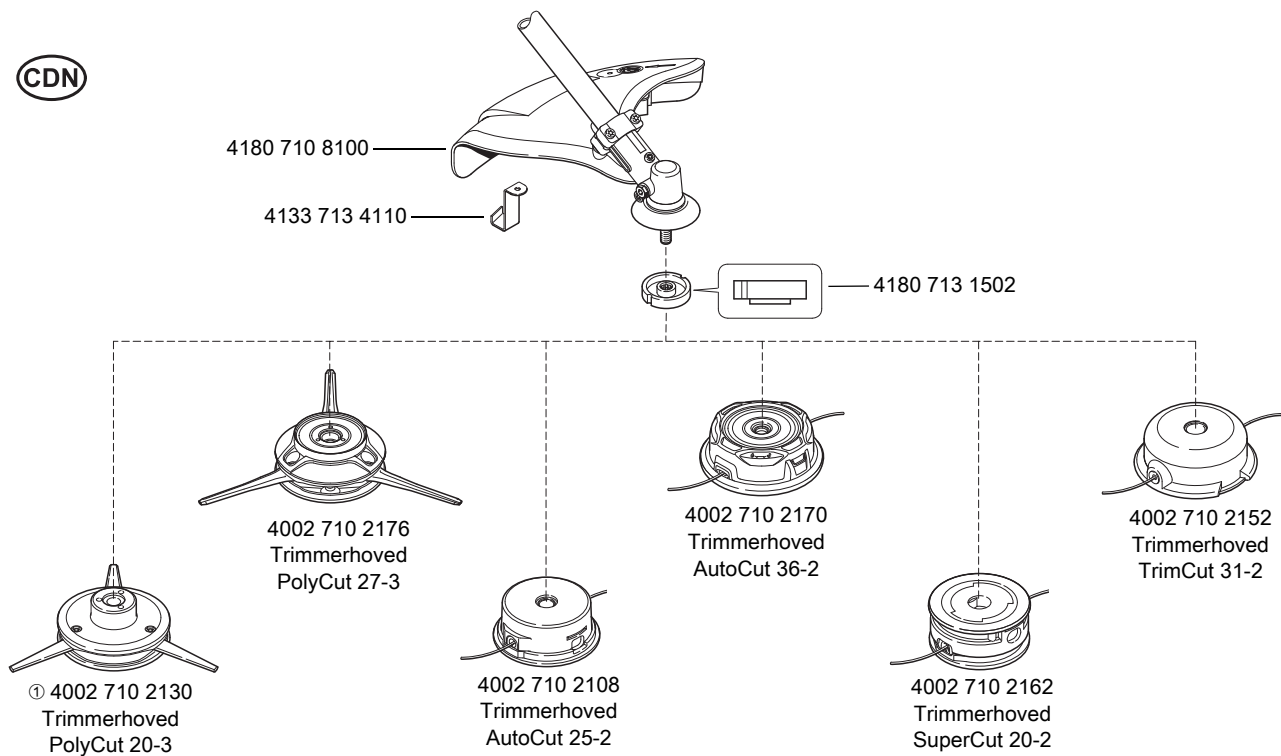

0000-GXX-5738-A0

① Leveres ikke længere

CDN

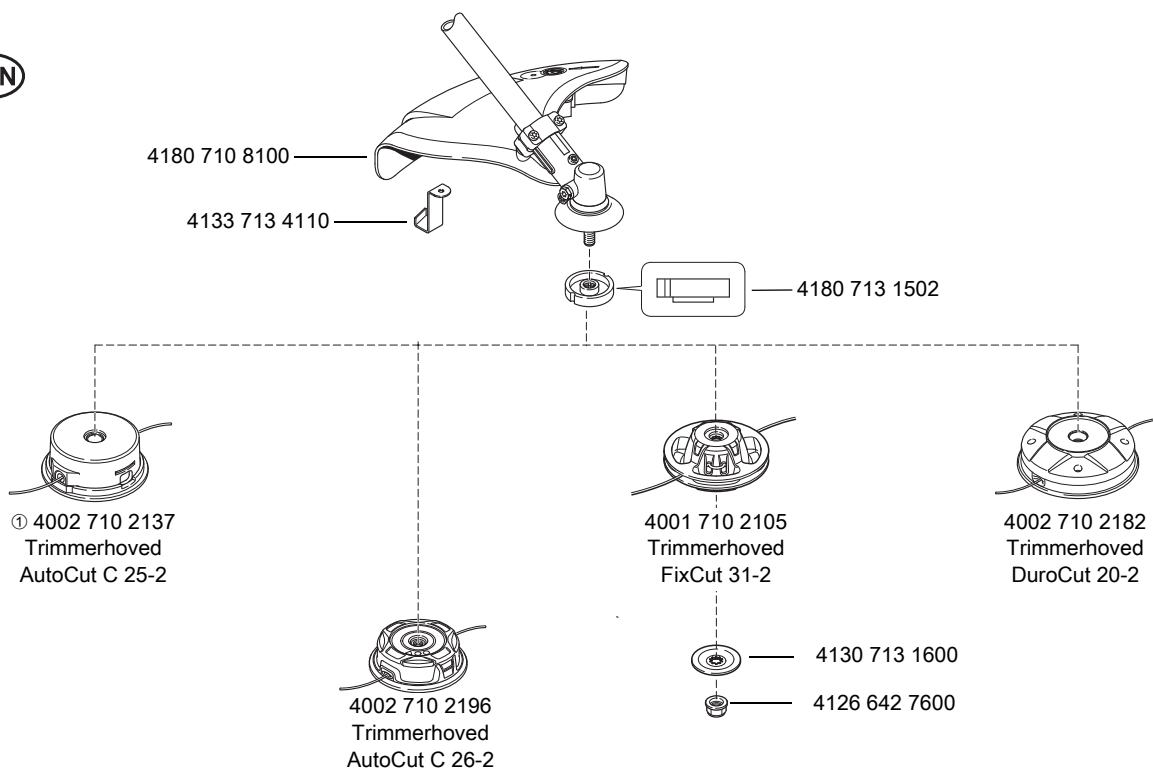

0000-GXX-3457-A1

① Leveres ikke længere

(a) fra 2016

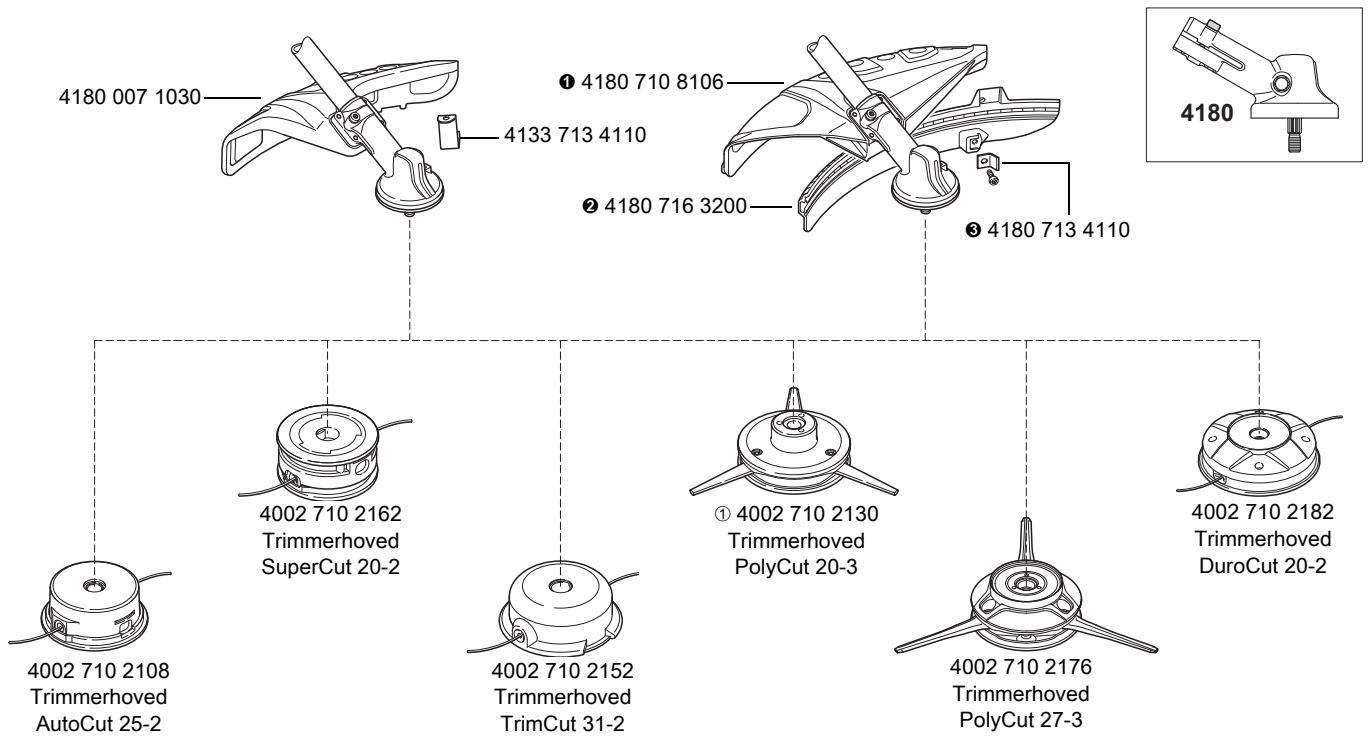

0000-GXX-5739-A0

① Leveres ikke længere

① + ② + ③ = 4180 007 1028

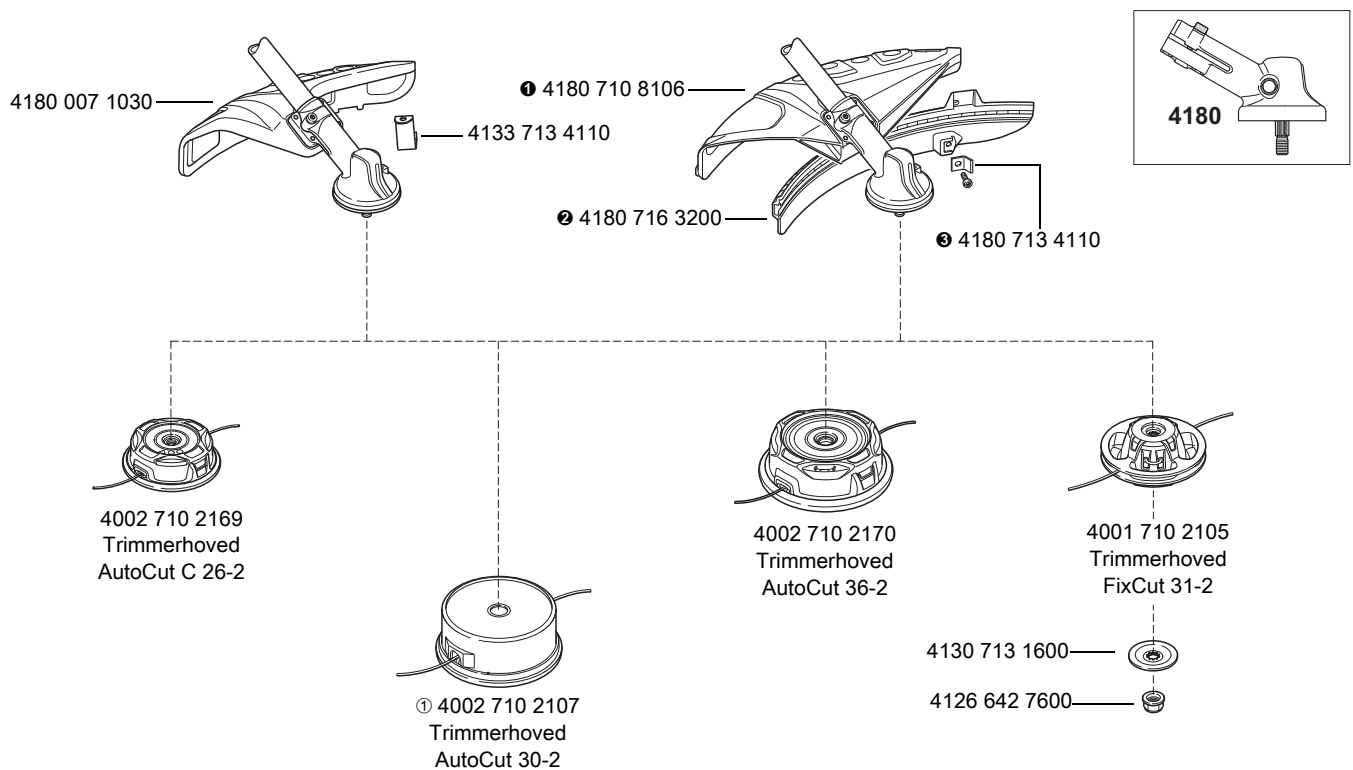

0000-GXX-5705-A0

① Leveres ikke længere

① + ② + ③ = 4180 007 1028

(a) fra 2016

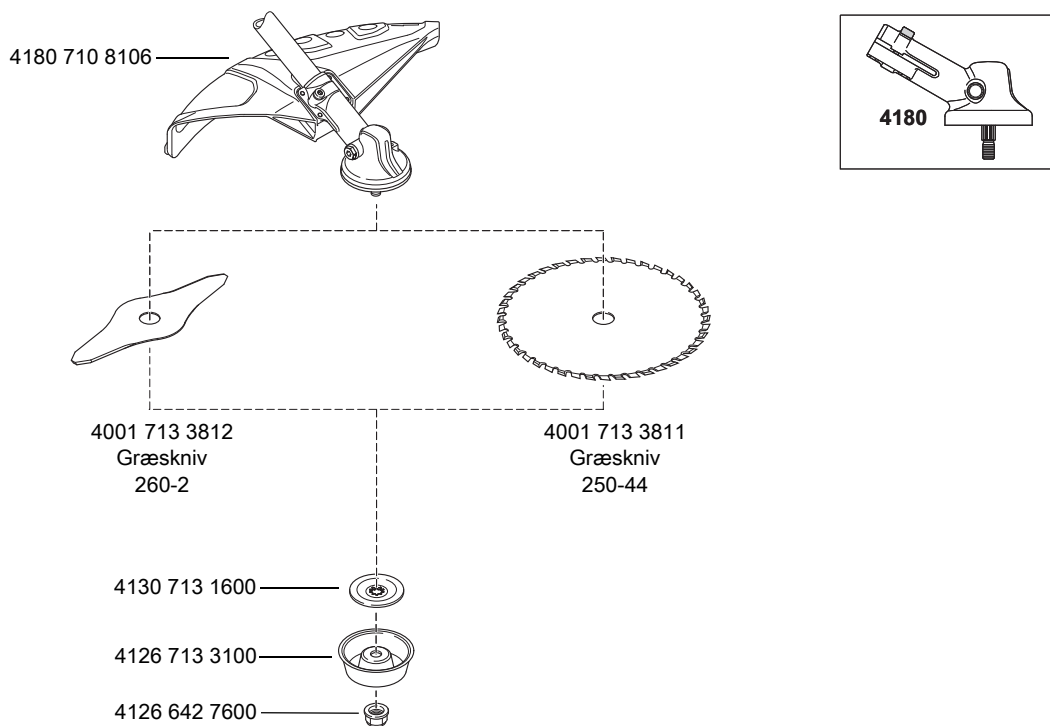
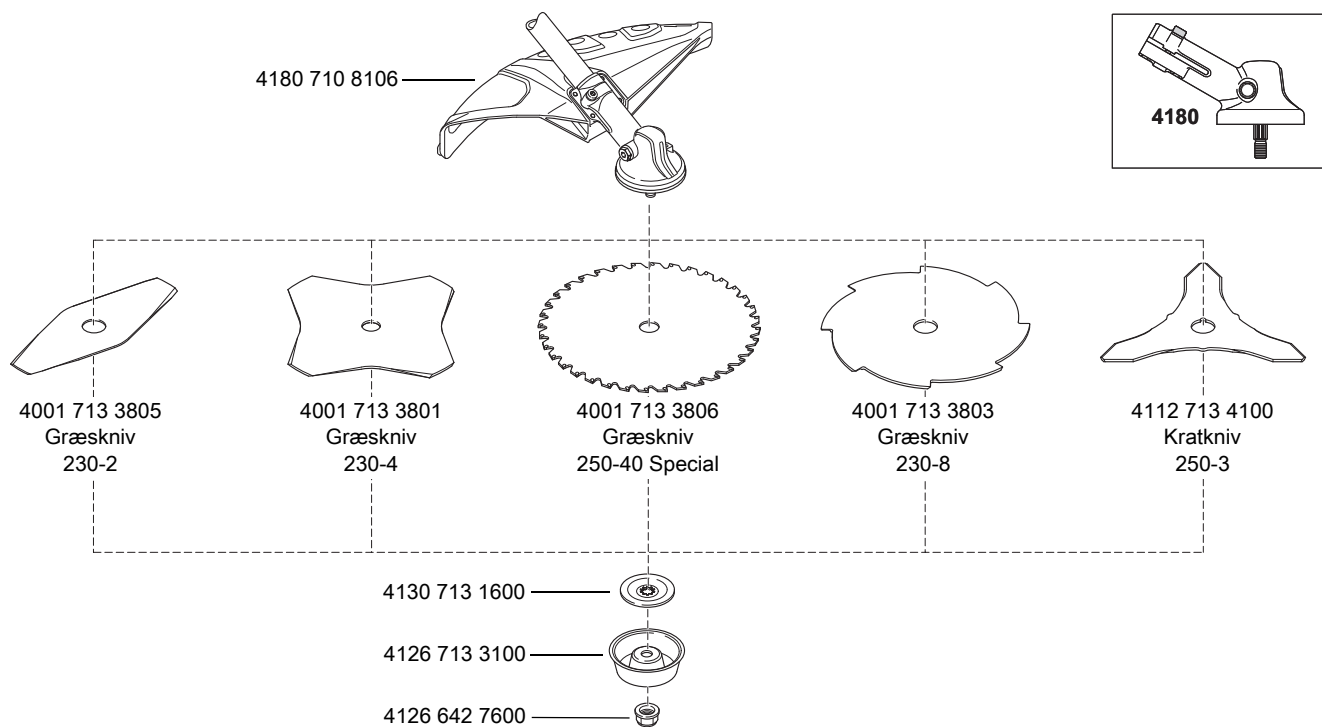

(a) fra 2016

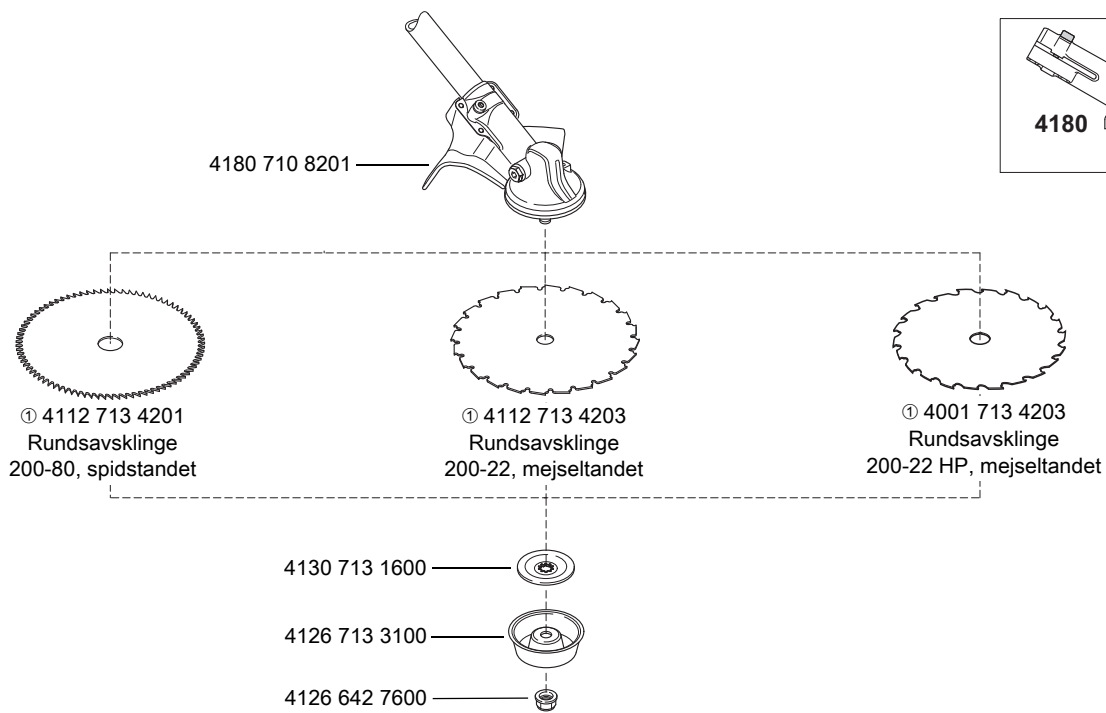

0000-GXX-5706-A0

① Ikke tilladt på trimmere med specialhåndtag

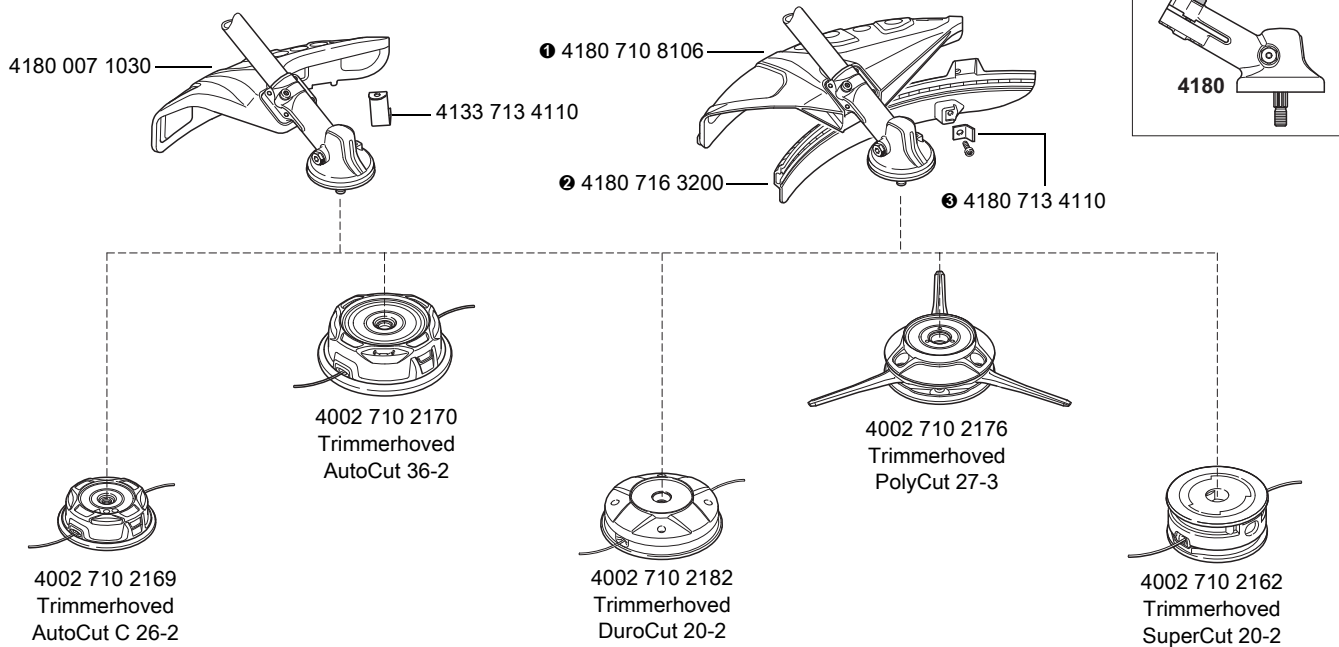

0000-GXX-8234-A0

1 + 2 + 3 = 4180 007 1028

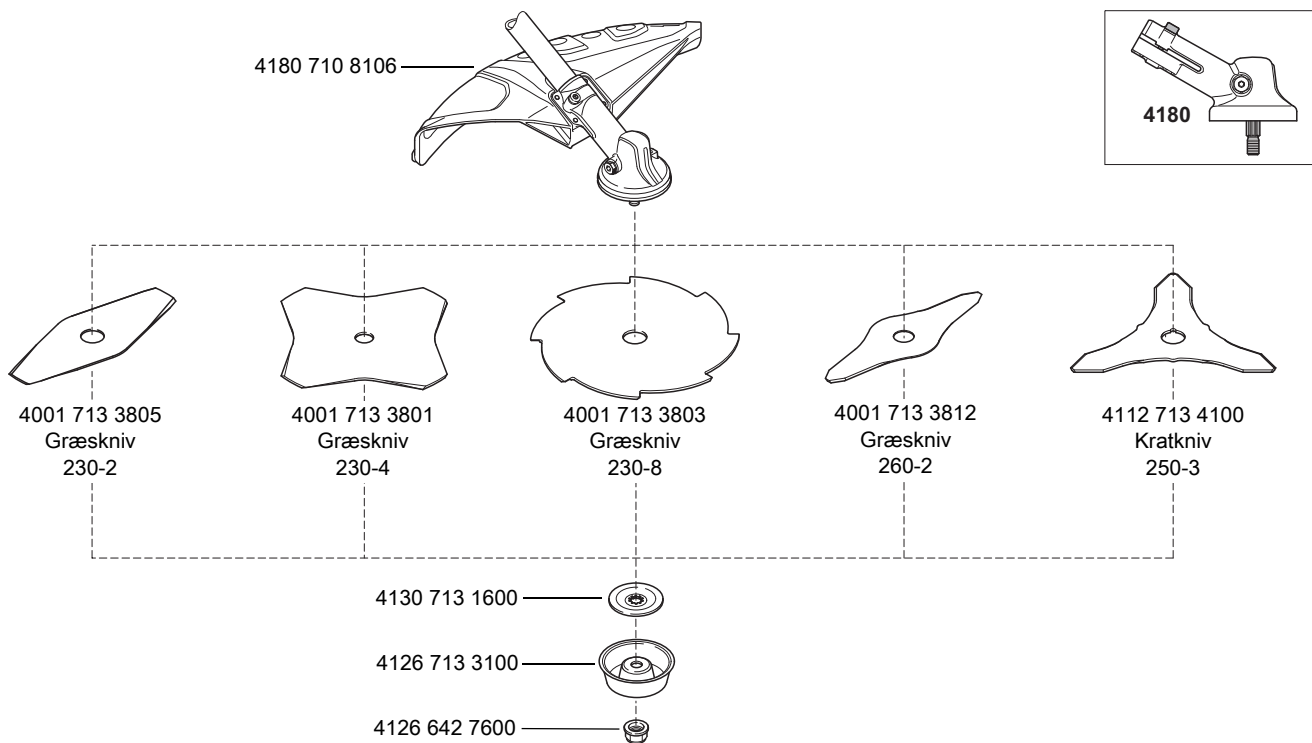

0000-GXX-8235-A0

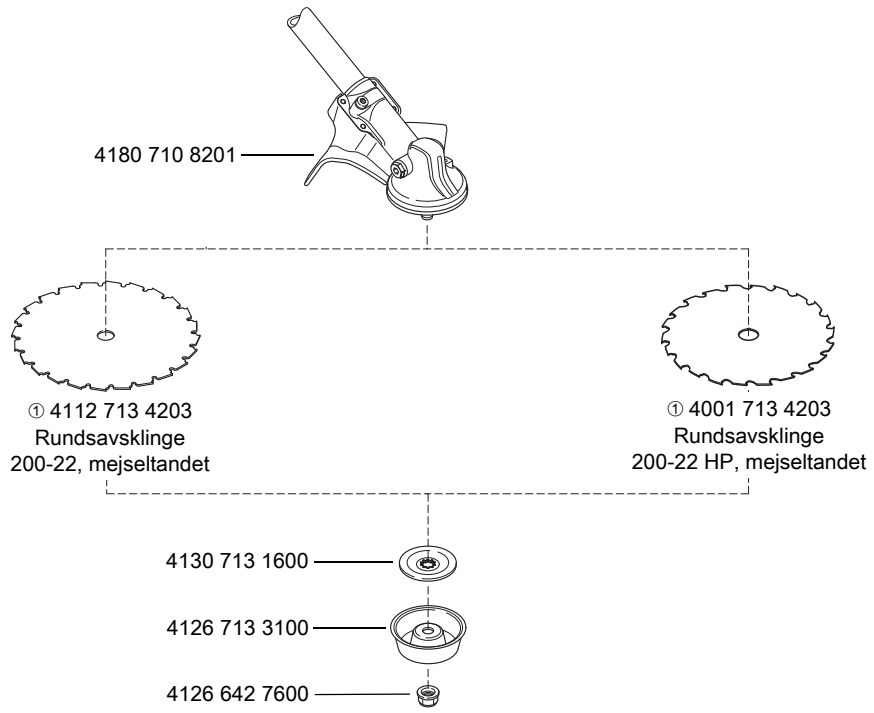

0000-GXX-8236-A0

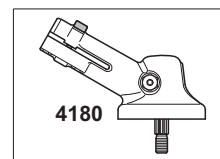
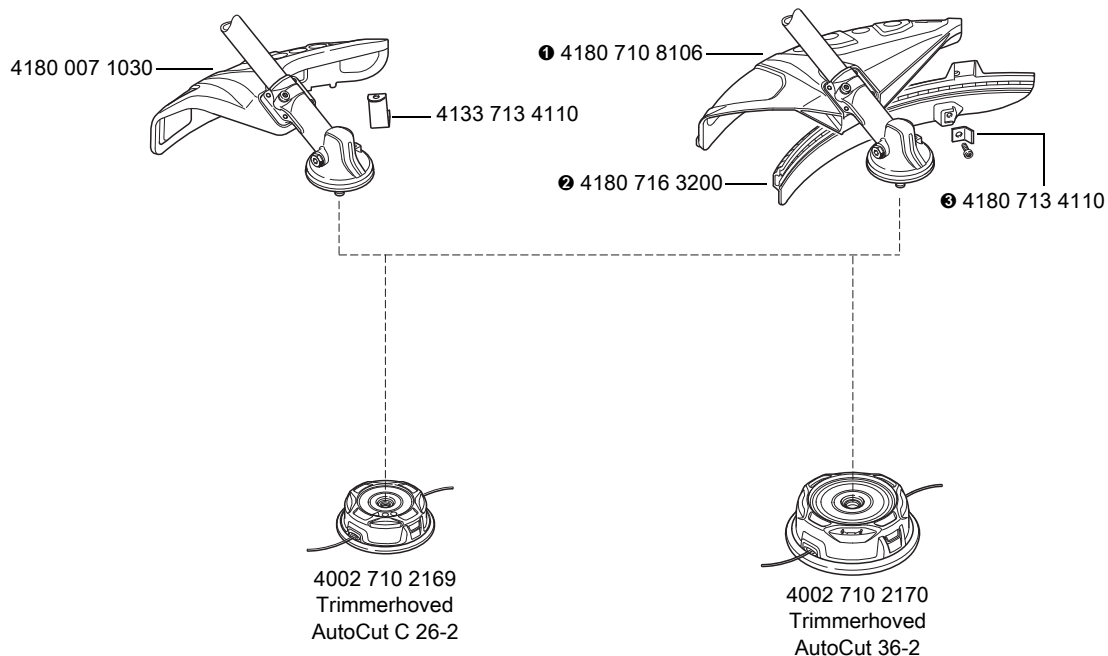

❶ + ❷ + ❸ = 4180 007 1028

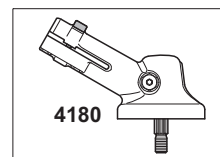
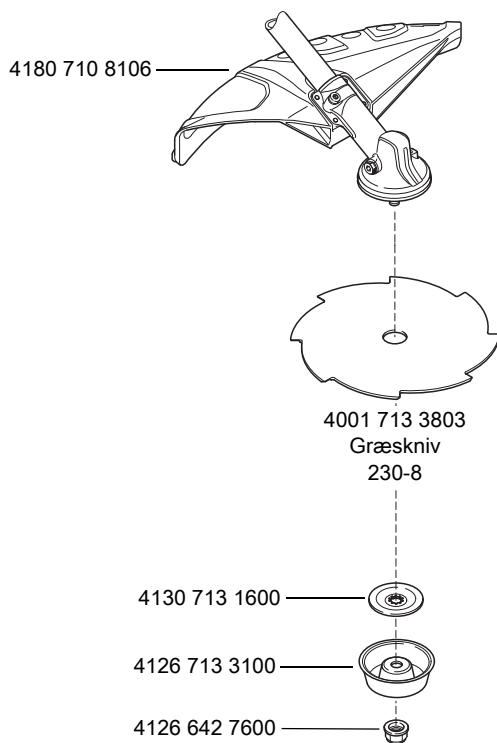

0000-GXX-8233-A0

0000-GXX-8232-A0

(a) fra 1997 (b) FS 260 med tohåndsgreb: side 85 (c) fra 2010

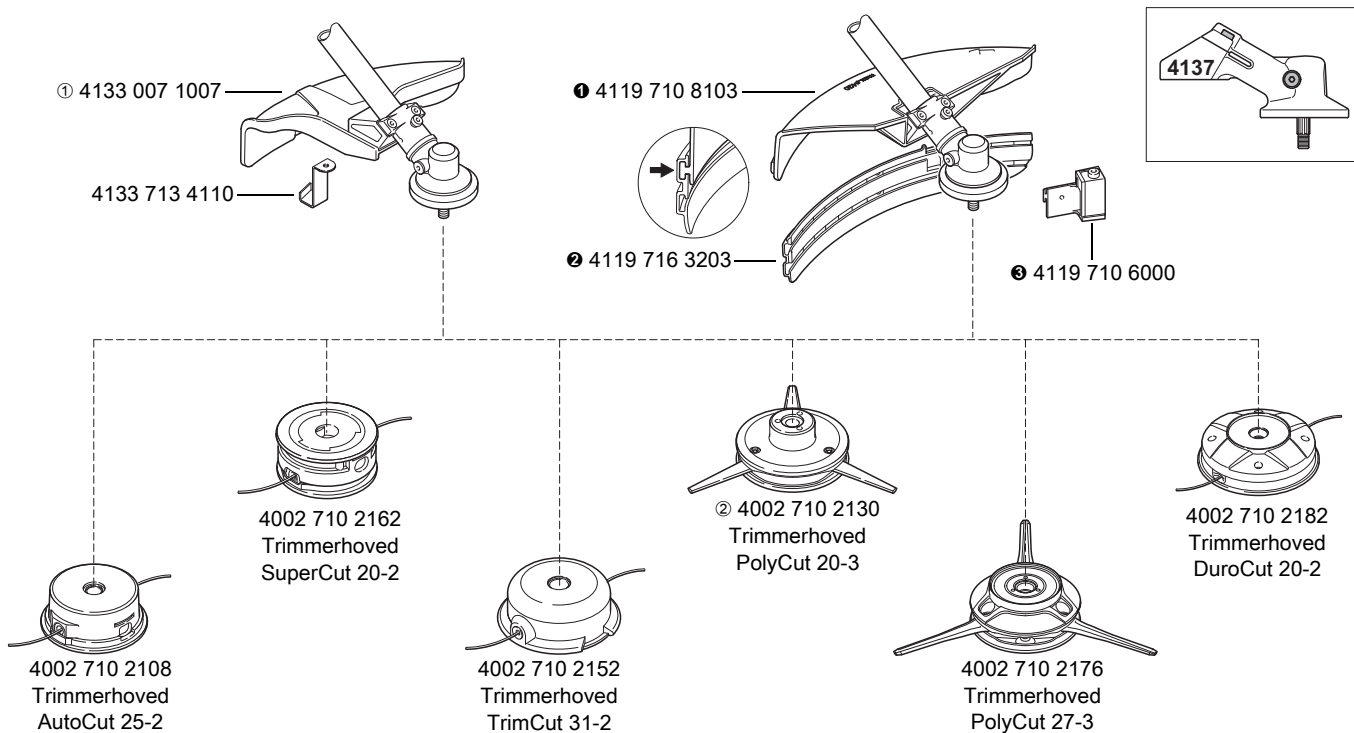

① Kun tilladt i AUS, NZL: 4133 007 1008

② Leveres ikke længere

① + ② + ③ = 4119 007 1027

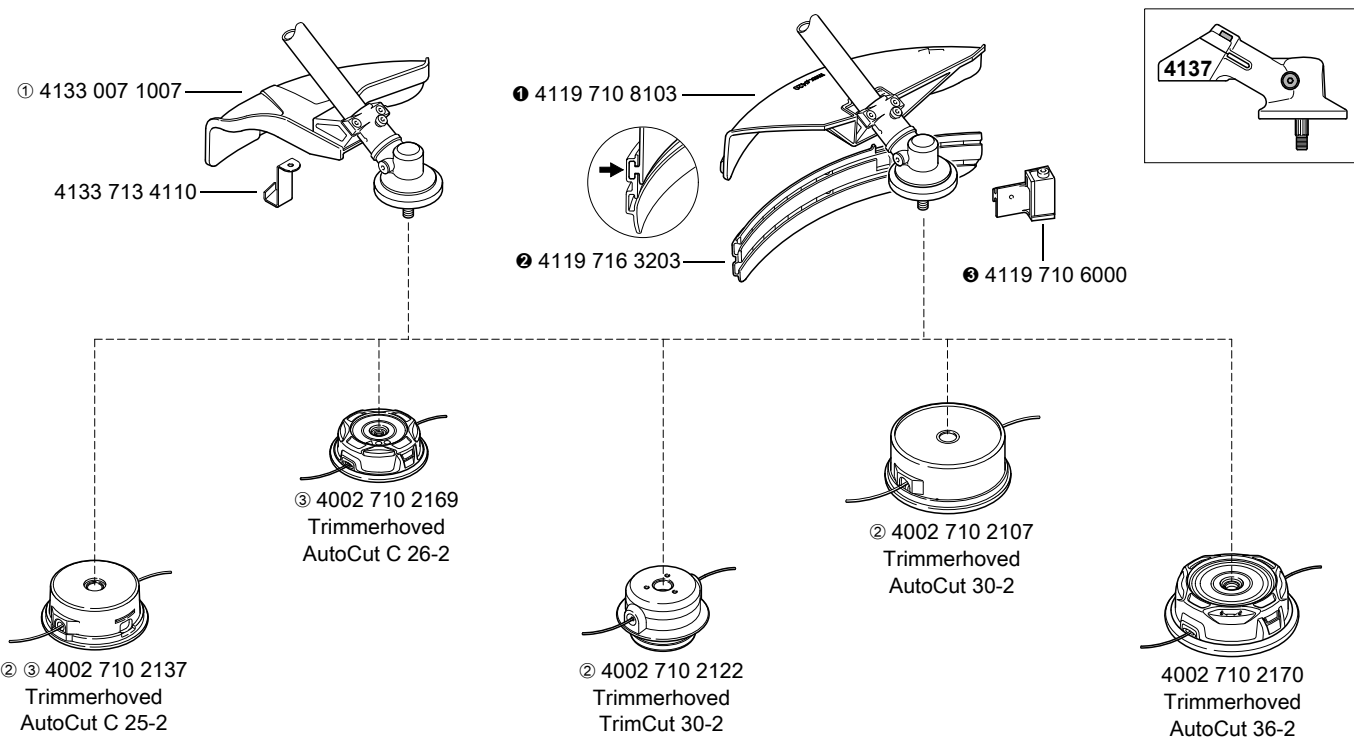

① Kun tilladt i AUS, NZ: 4133 007 1008

① + ② + ③ = 4119 007 1027

② Leveres ikke længere

③ Ikke tilladt til FS 120, 200, 240, 250, 260 R, 460 R

(a) fra 1997 (b) FS 260 med tohåndsgreb: side 85 (c) fra 2010

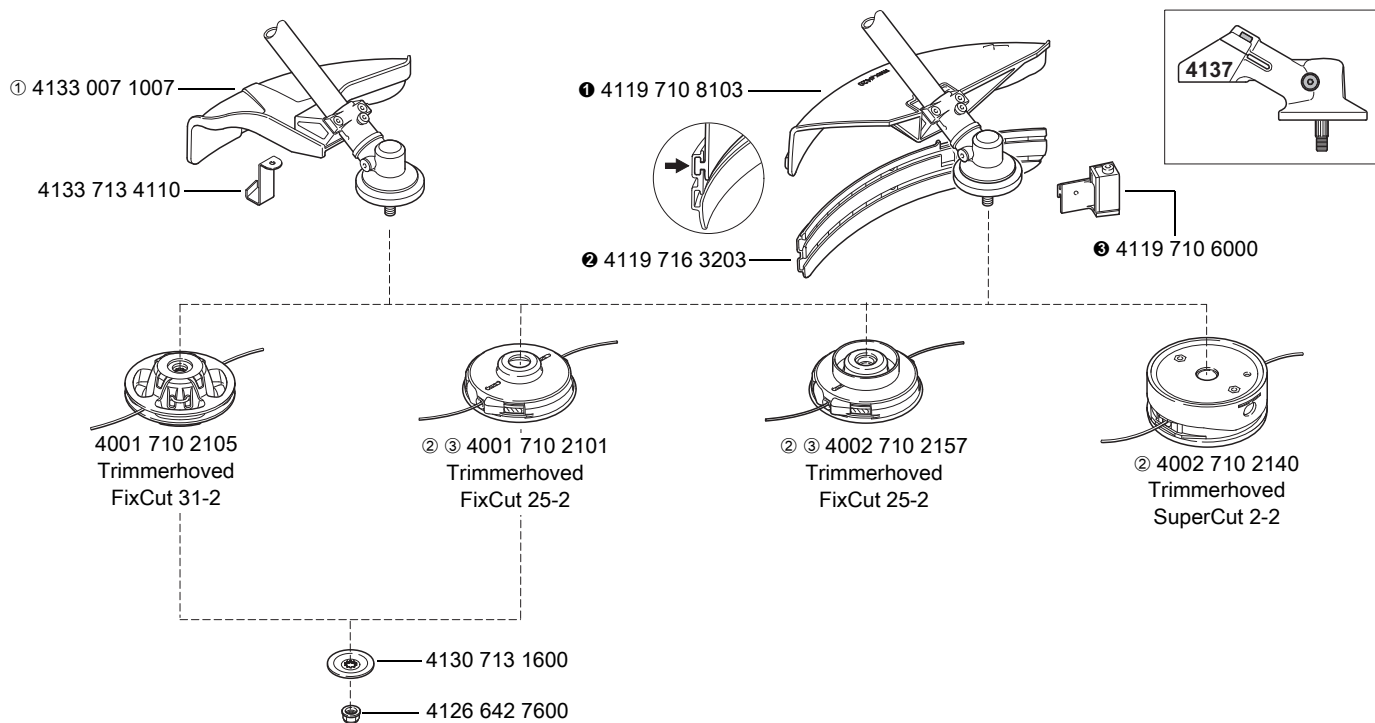

0000-GXX-5707-A0

① Kun tilladt i AUS, NZ: 4133 007 1008

① + ② + ③ = 4119 007 1027

② Leveres ikke længere

③ Ikke tilladt til FS 240, 240 R, 260 R, 460 R

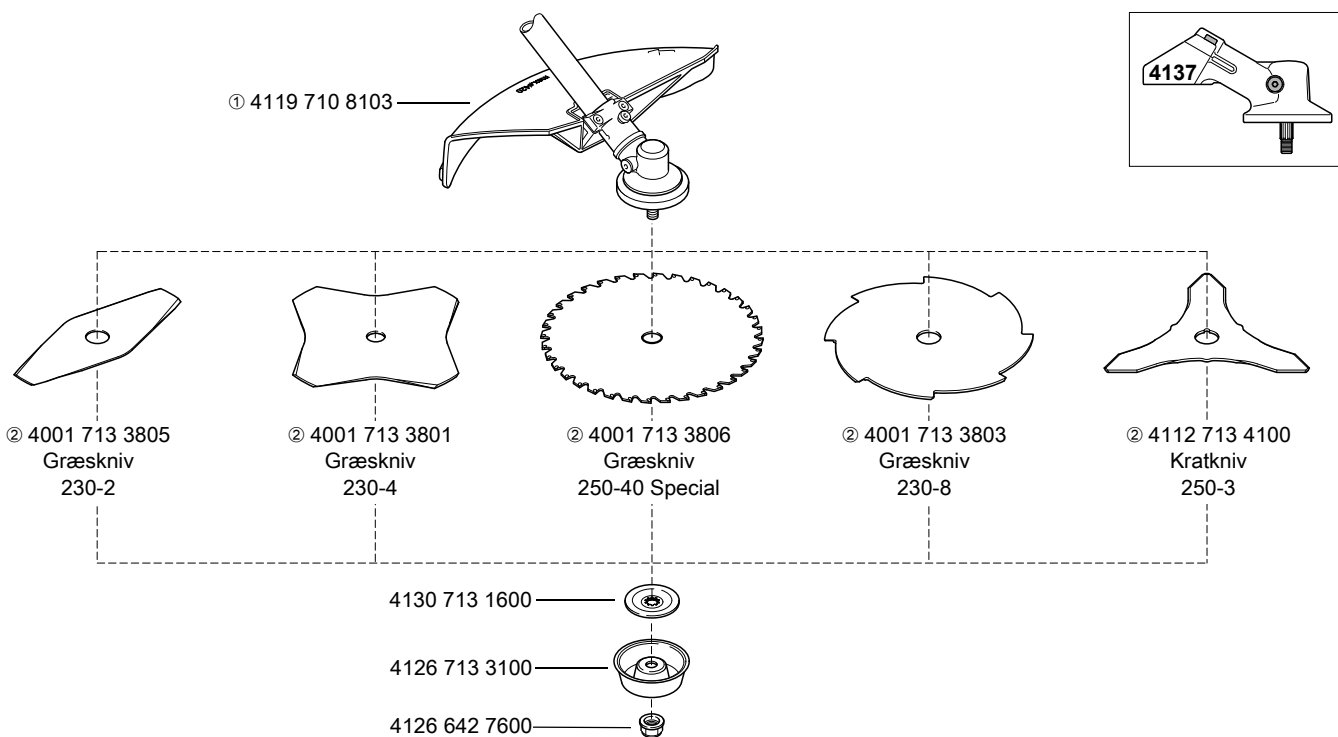

681KT1072 KN

① Beskyttelse til AUS, NZ, se billedet med "AUS, NZ"

② Ikke tilladt til FS 200 R, 250 R inden for EU

(a) fra 1997 (b) FS 260 med tohåndsgreb: side 85 (c) fra 2010

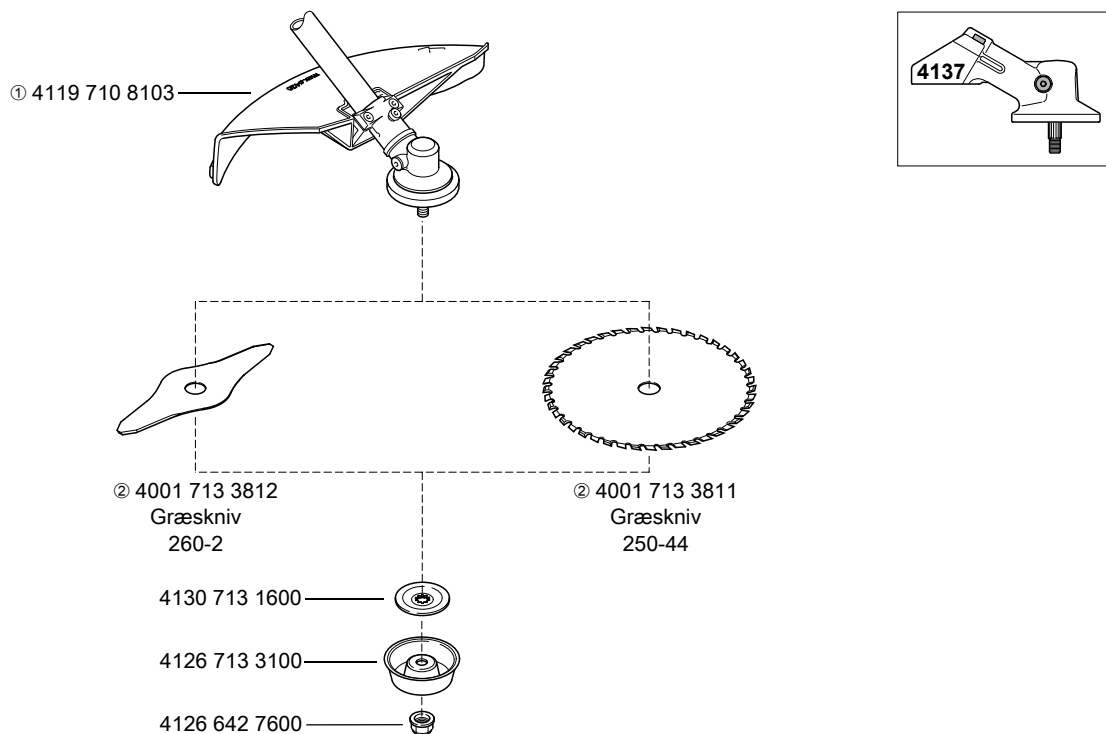

681KT1073 KN

① Beskyttelse til AUS, NZ, se billedet med "AUS, NZ"

② Ikke tilladt til FS 200 R, 250 R inden for EU

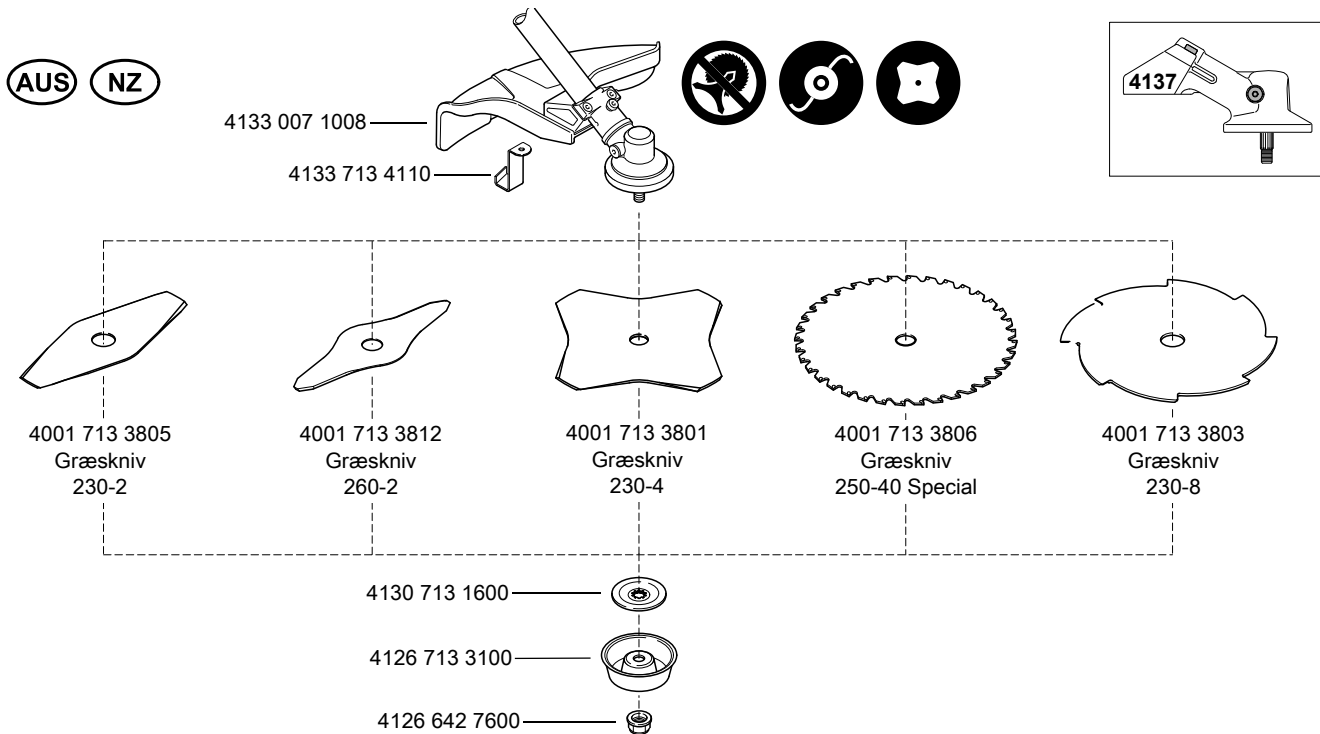

681KT1074 KN

(a) fra 1997 (b) FS 260 med tohåndsgreb: side 85 (c) fra 2010

AUS NZ

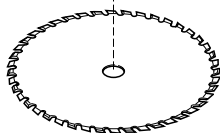
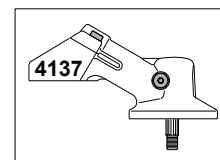
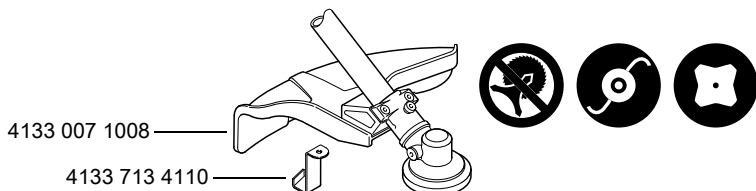

4001 713 3811
Græskniv
250-44

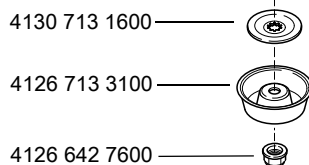

681KT118 KN

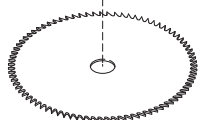
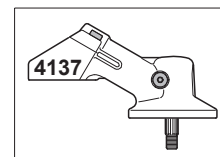
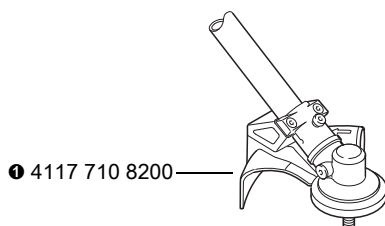

① 4112 713 4201
Rundsavsklinge
200-80, spidstandet

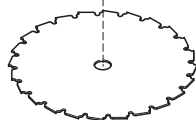

① 4112 713 4203
Rundsavsklinge
200-22, mejseltandet

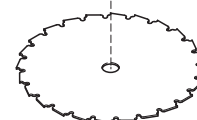

① 4001 713 4203
Rundsavsklinge
200-22 HP, mejseltandet

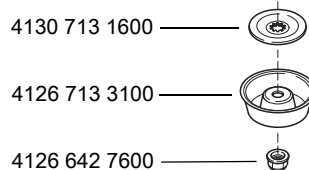

381KT1075-A1

① Ikke tilladt på trimmere med specialhåndtag

● + transportbeskyttelse = 4126 007 1002

(a) fra 2015

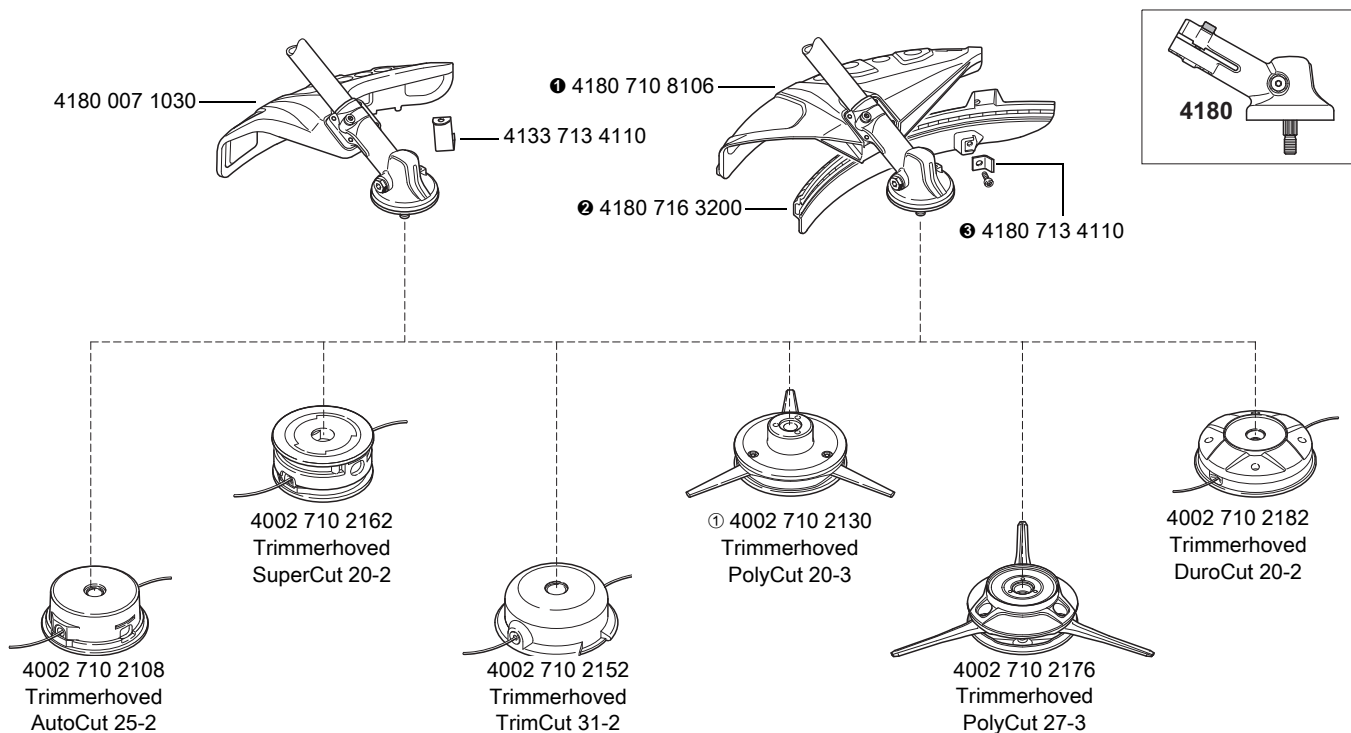

0000-GXX-5741-A0

① Leveres ikke længere

① + ② + ③ = 4180 007 1028

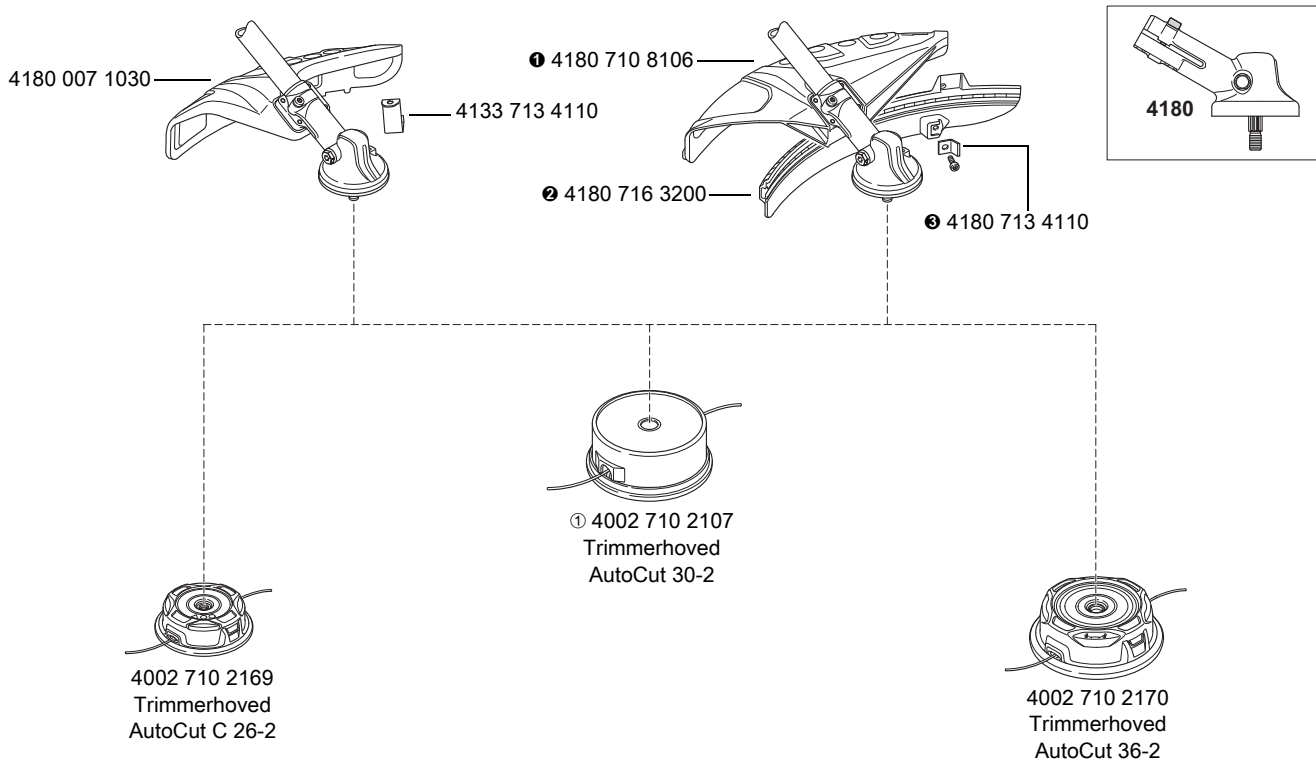

0000-GXX-3467-A0

① Leveres ikke længere

① + ② + ③ = 4180 007 1028

(a) fra 2015

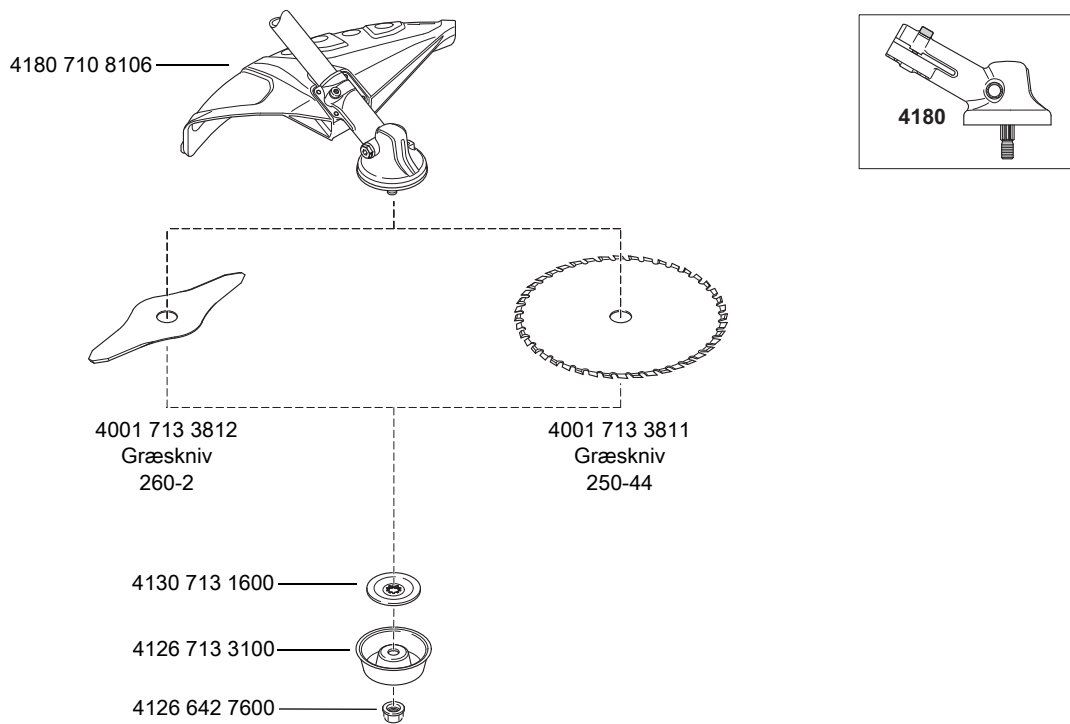
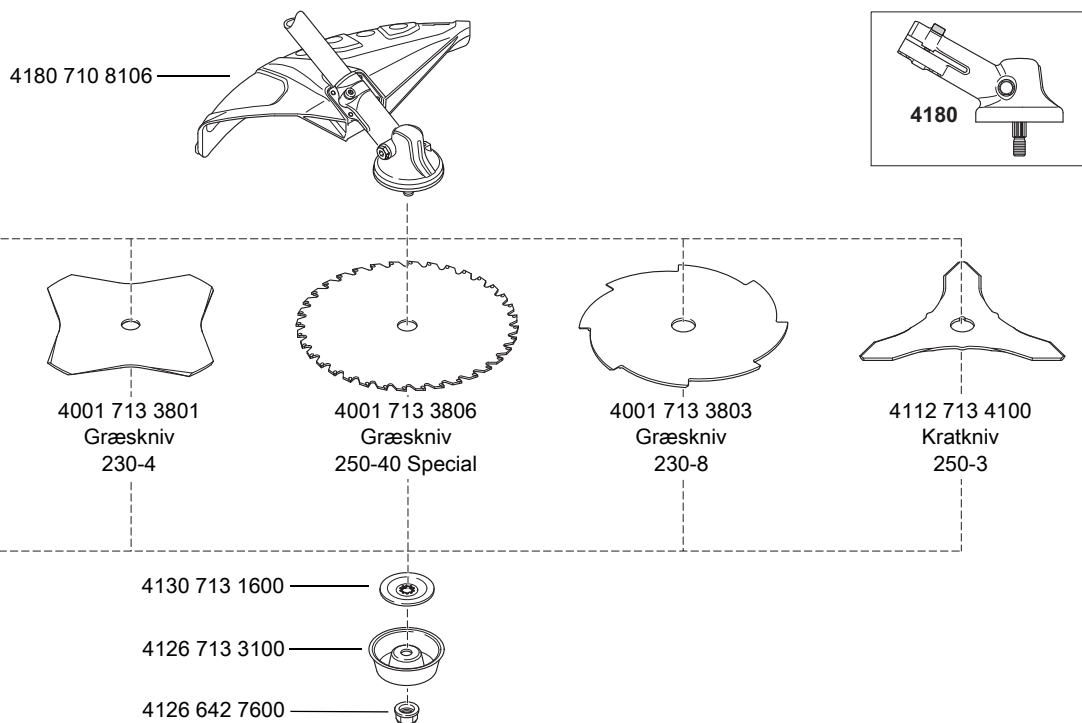

(a) fra 2015

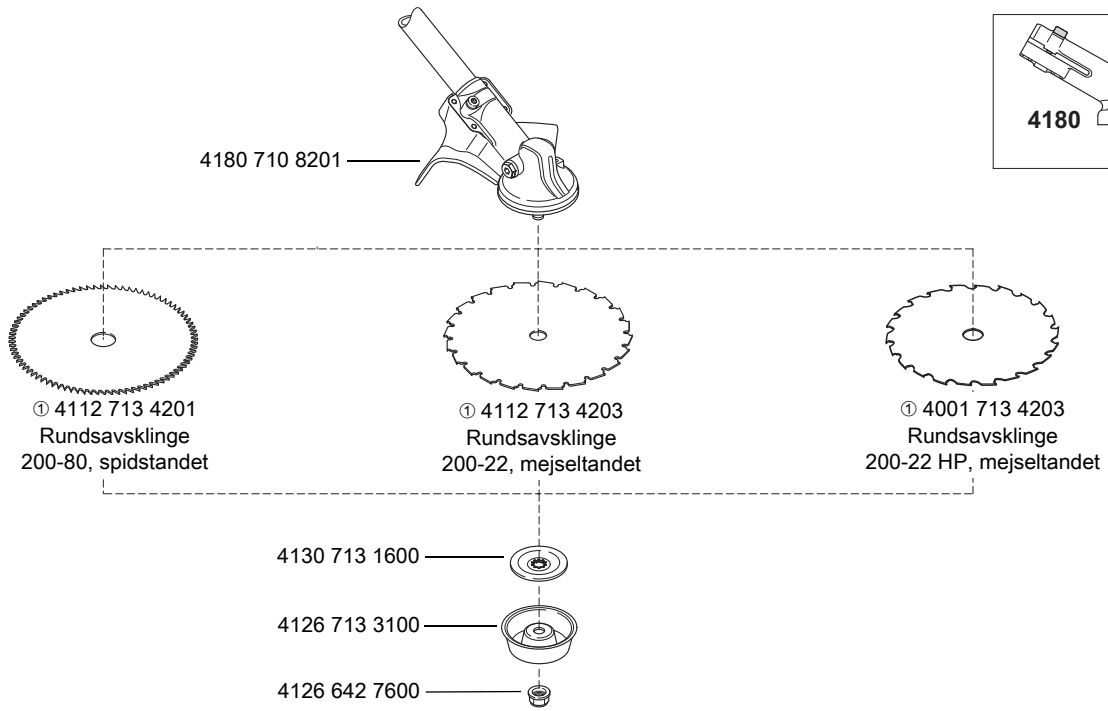

0000-GXX-5708-A0

① Ikke tilladt på trimmere med specialhåndtag

(a) indtil 1988 (b) indtil 1986

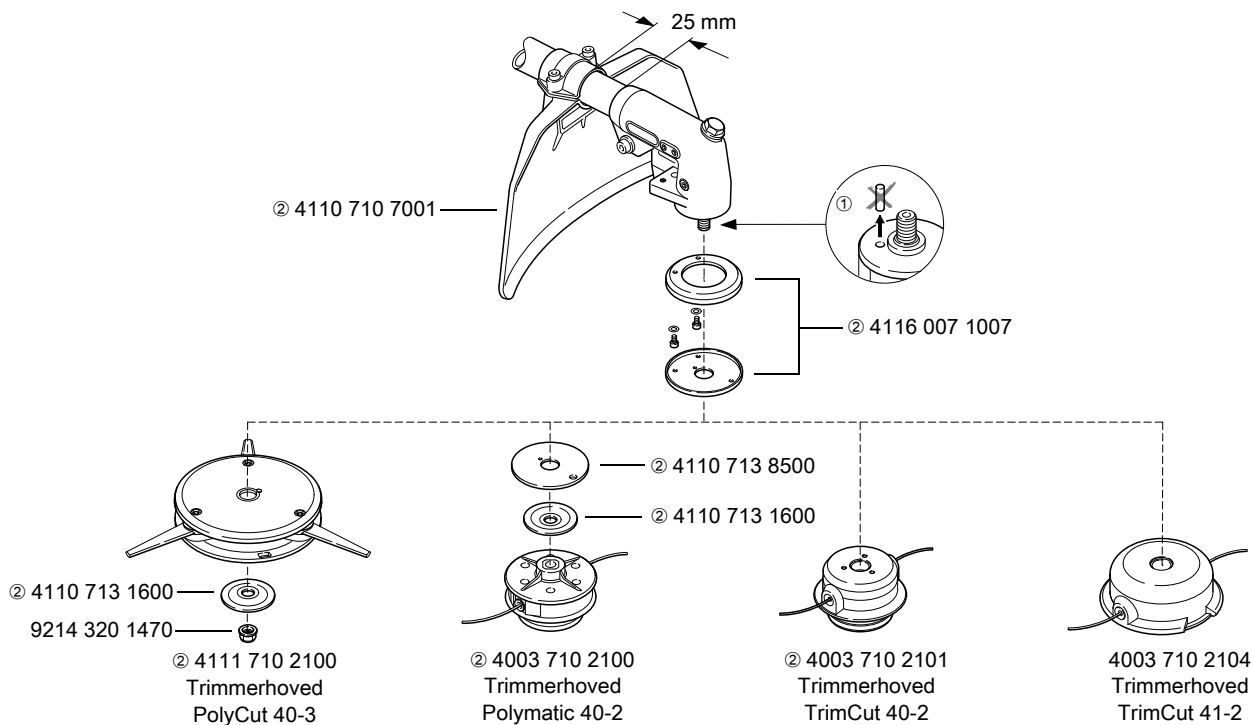

681KT527 KN

① Til TrimCut 40-2, TrimCut 41-2

② Leveres ikke længere

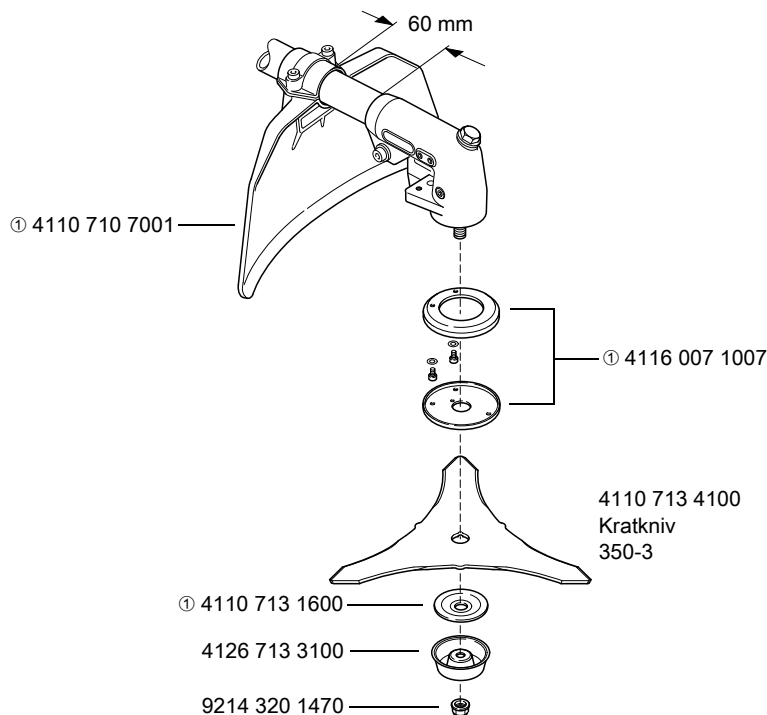

681KT866 KN

① Leveres ikke længere

(a) indtil 1988 (b) indtil 1986

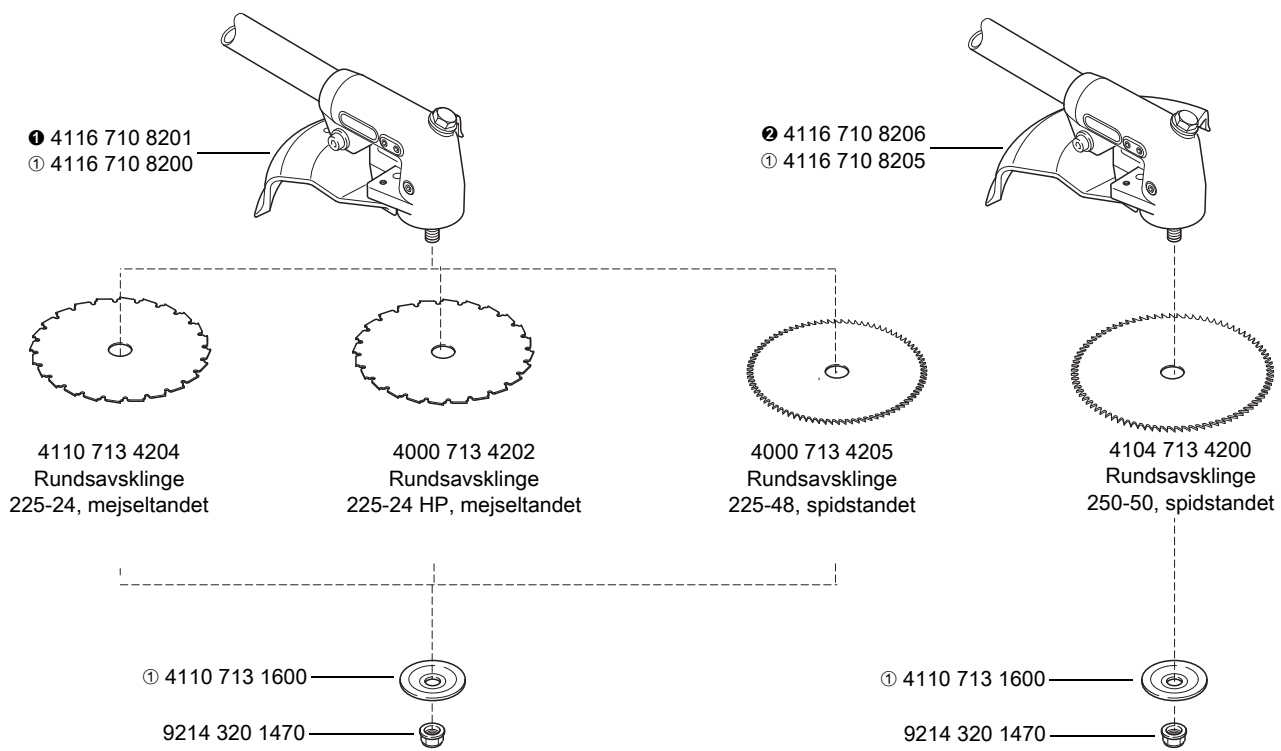

681KT528-A1

① Leveres ikke længere

① + transportbeskyttelse = 4116 007 1019

② + transportbeskyttelse = 4116 710 1018

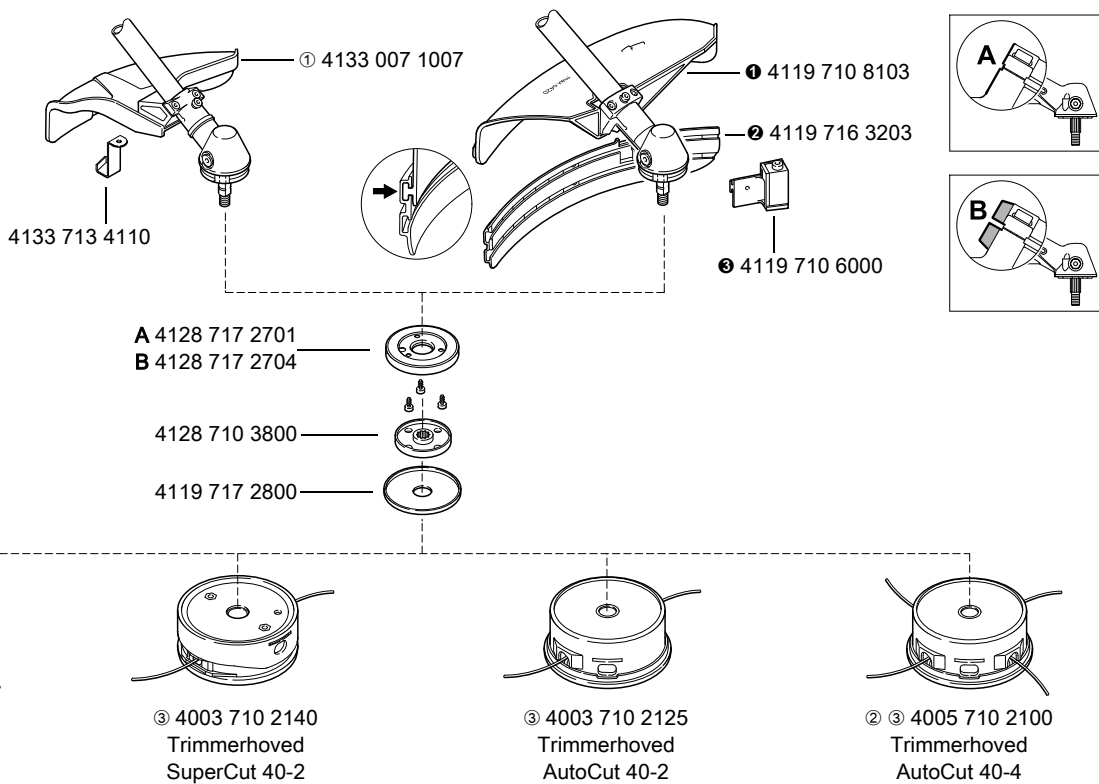
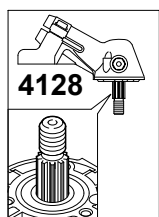

681KT575 KN

① Kun tilladt i AUS, NZL: 4133 007 1008

① + ② + ③ = 4119 007 1027

② Ikke tilladt til FS 160, 220, 300, 310, 350, 400

③ Leveres ikke længere

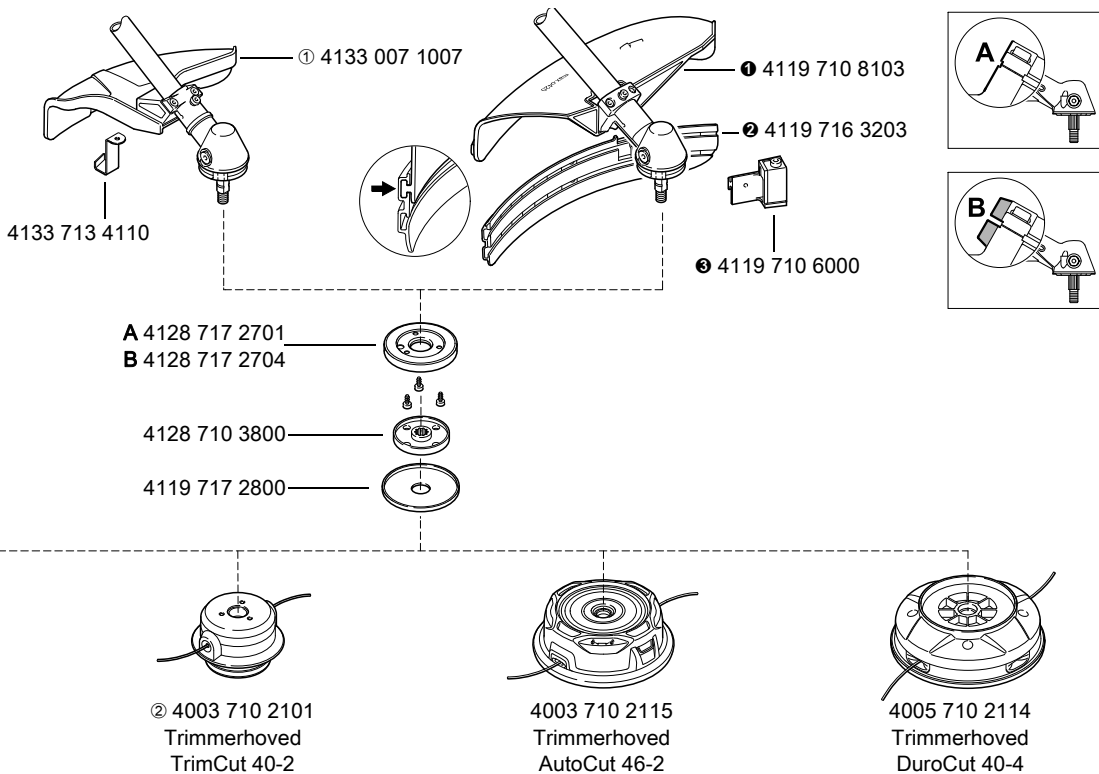
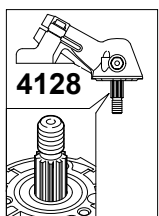

681KT1081 KN

① Kun tilladt i AUS, NZ: 4133 007 1008

② Leveres ikke længere

① + ② + ③ = 4119 007 1027

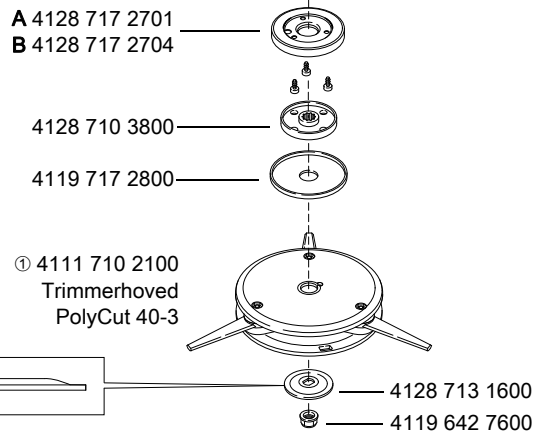
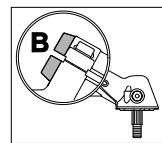
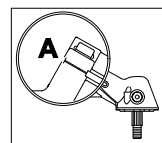
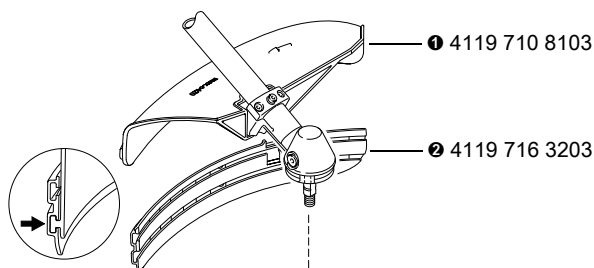
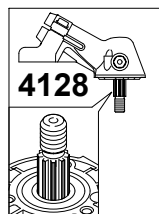

681KT807 KN

① Leveres ikke længere

① + ② = 4119 007 1027

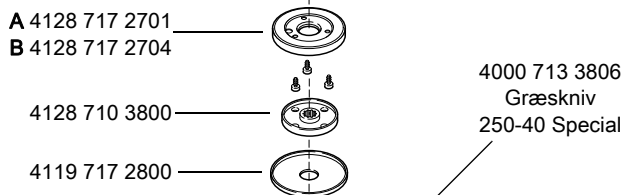
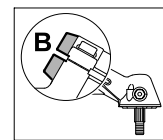
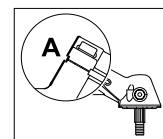
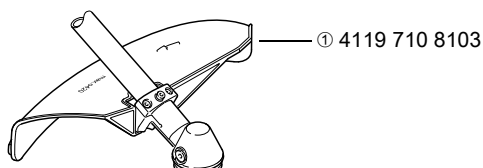
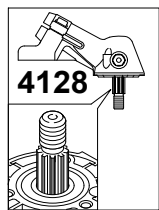

4000 713 3802
Græskniv
255-8

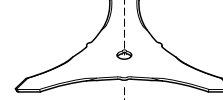
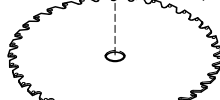
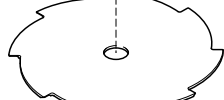
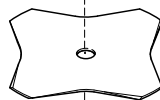

4000 713 3801
Græskniv
230-4

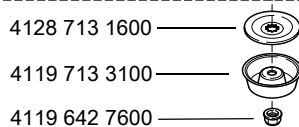

4000 713 4103
Kratkniv
305-2 Special

4119 713 4100
Kratkniv
300-3

681KT576 KN

① Beskyttelse til AUS, NZ, se billedet med "AUS, NZ"

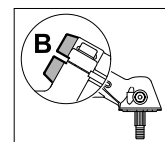
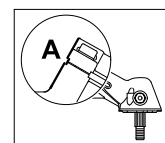
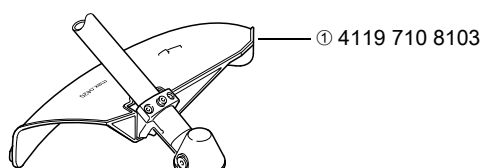
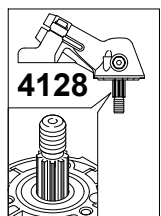

A 4128 717 2701
B 4128 717 2704

4128 710 3800

4119 717 2800

4000 713 3811
Græskniv
250-44

4128 713 1600

4119 713 3100

4119 642 7600

① Beskyttelse til AUS, NZ, se billedet med "AUS, NZ"

681KT1082 KN

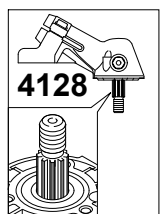

(AUS) (NZ)

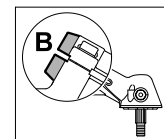
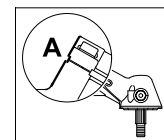
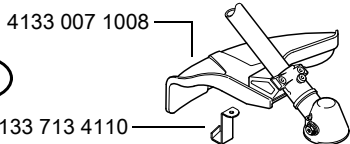

4133 713 4110

A 4128 717 2701
B 4128 717 2704

4128 710 3800

4119 717 2800

4000 713 3802
Græskniv
255-8

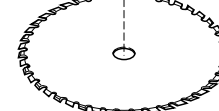
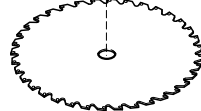
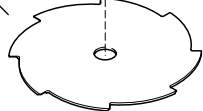
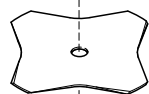

4000 713 3801
Græskniv
230-4

4128 713 1600

4000 713 3806
Græskniv
250-40 special

4001 713 3811
Græskniv
250-44

4119 713 3100

4119 642 7600

681KT1119 KN

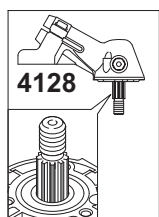

A 4128 717 2706
B 4128 717 2707

4128 710 3800

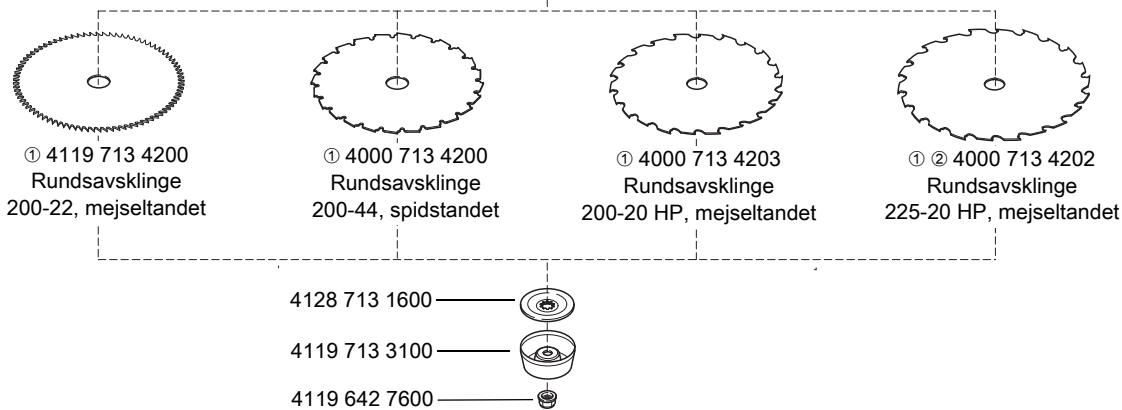
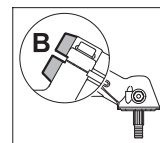
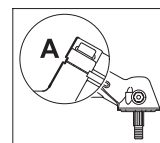

0000-GXX-5709-A0

① Ikke tilladt på trimmere med specialhåndtag

② Ikke tilladt til FS 310

Ⓜ + Transportsbeskyttelse = 4126 007 1002

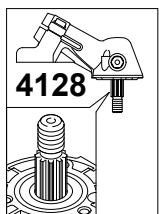

A 4128 717 2706
B 4128 717 2707

4128 710 3800

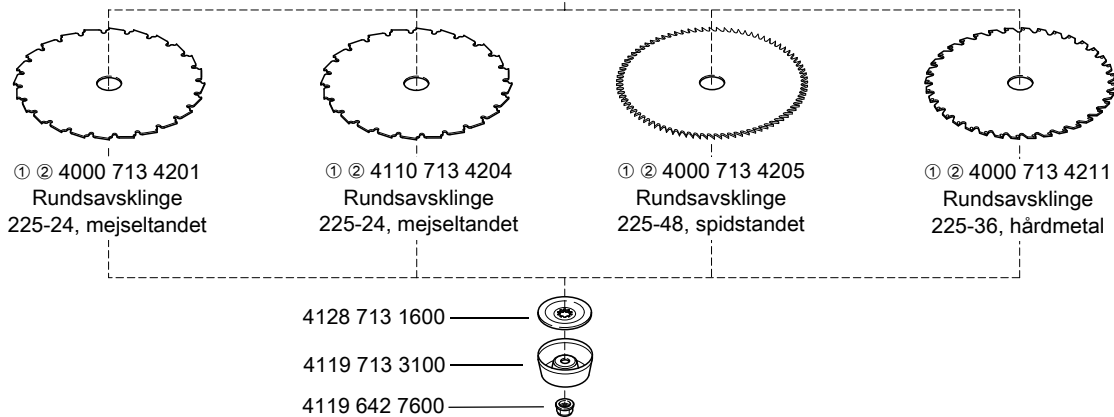
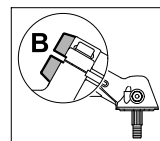
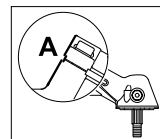

681KT868 KN

① Ikke tilladt til FS 310

① Ikke tilladt på trimmere med specialhåndtag

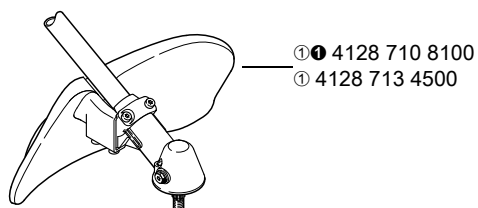
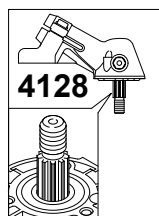

① 4128 710 8100
① 4128 713 4500

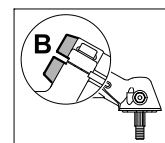
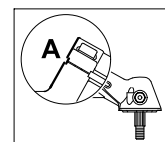

A 4128 717 2701
B 4128 717 2704

4128 710 3800

4119 717 2800

②③ 4000 713 3903
Snittekniv
270-2

4128 713 1600

4116 713 3100

4119 642 7600

① 4116 717 2700
③ 4116 717 2702

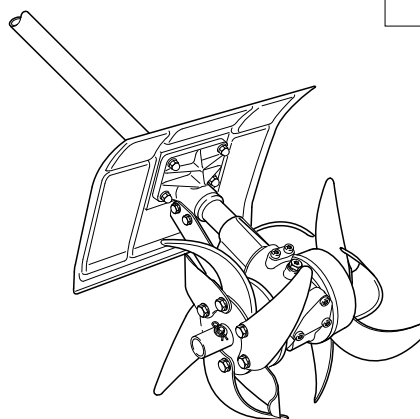

① ② 4600 710 1501
Jordkultivator BC 40

68:1KT578:KN

- ① Leveres ikke længere
- ② Ikke tilladt på trimmere med specialhåndtag
- ③ Tilladt på FS 160 fra maskinnummer 3 50 609 048

- ① + ② + ③ = 4128 007 1008
- ① + ③ = 4128 007 1007

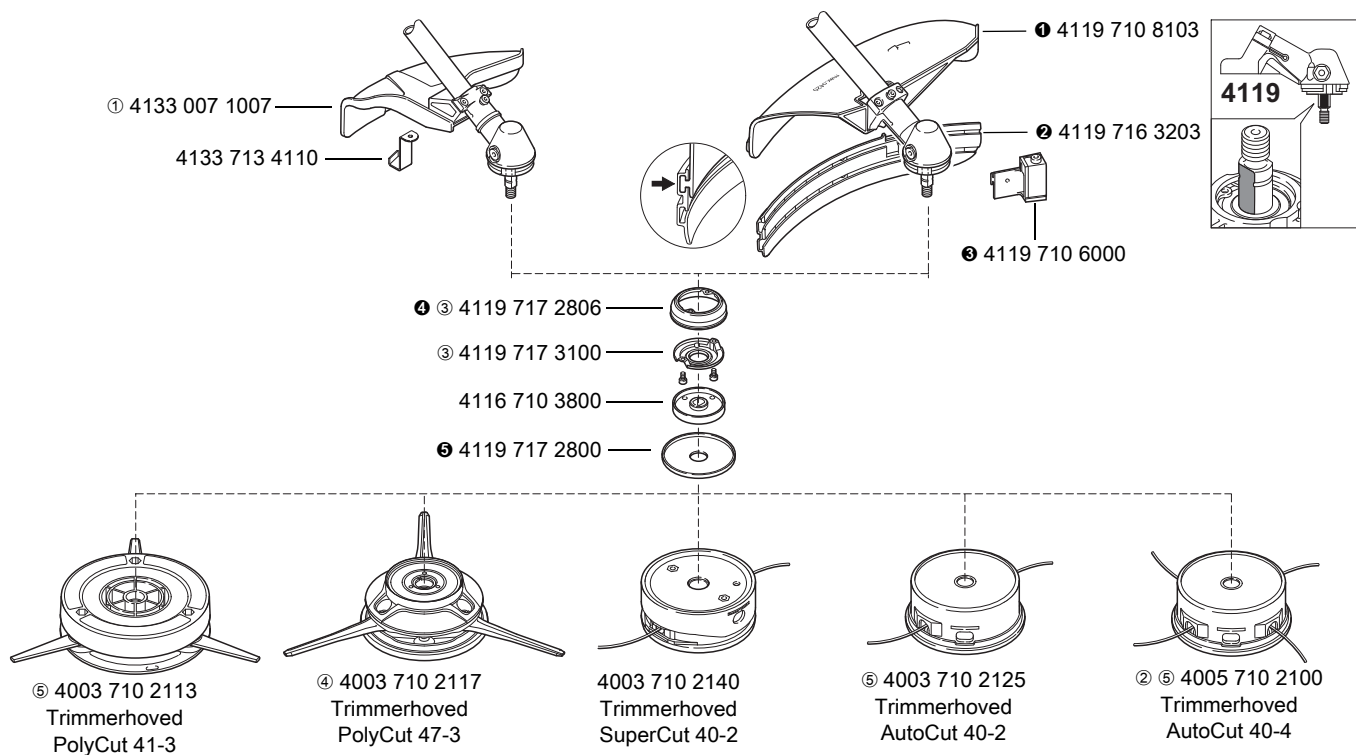

0000-GXX-5742-A0

① Kun tilladt i AUS, NZ: 4133 007 1008

② Ikke tilladt til FS 160, 180, 220, 300, 350, 400

③ Kun til drev med påskruet beskyttelsesring

④ Kun tilladt på FS 180, 280, 400, 450

⑤ Leveres ikke længere

① + ② + ③ = 4119 007 1027 / ④ + ⑤ = 4119 007 1021

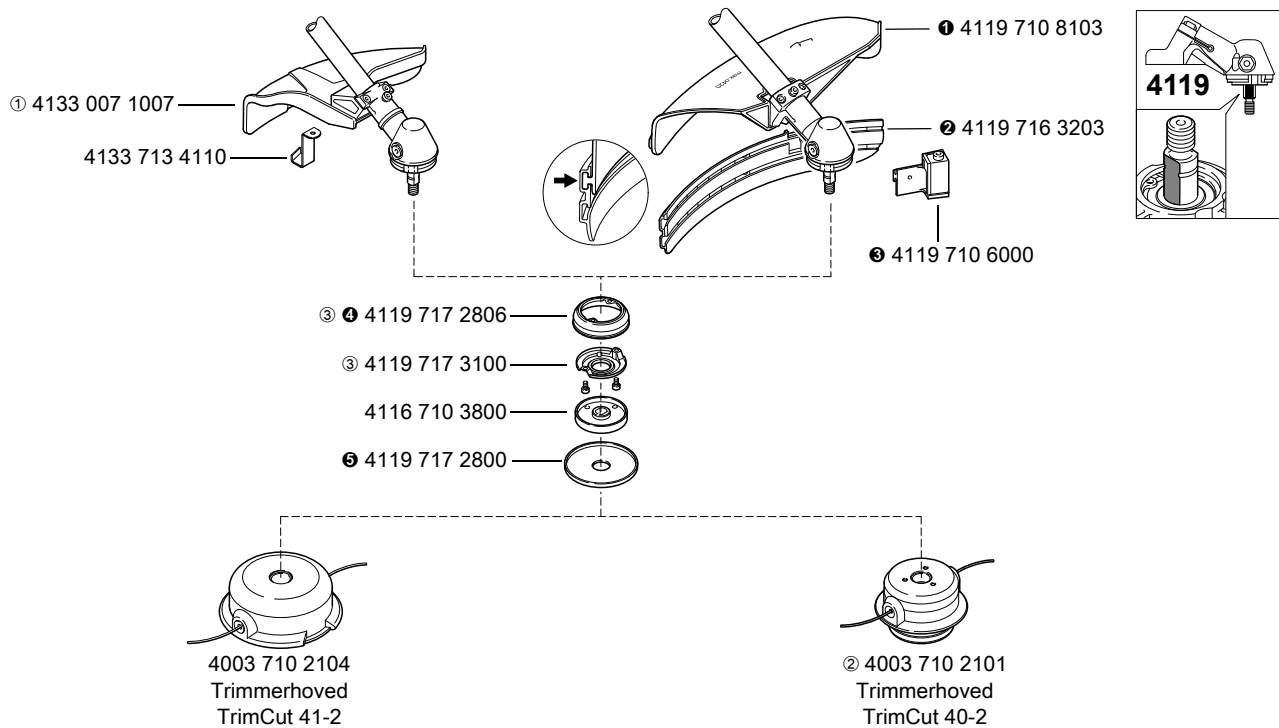

0000-GXX-3468-A0

① Kun tilladt i AUS, NZ: 4133 007 1008

② Leveres ikke længere

③ Kun til drev med påskruet beskyttelsesring

① + ② + ③ = 4119 007 1027

④ + ⑤ = 4119 007 1021

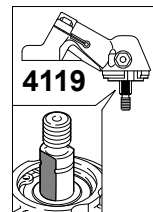
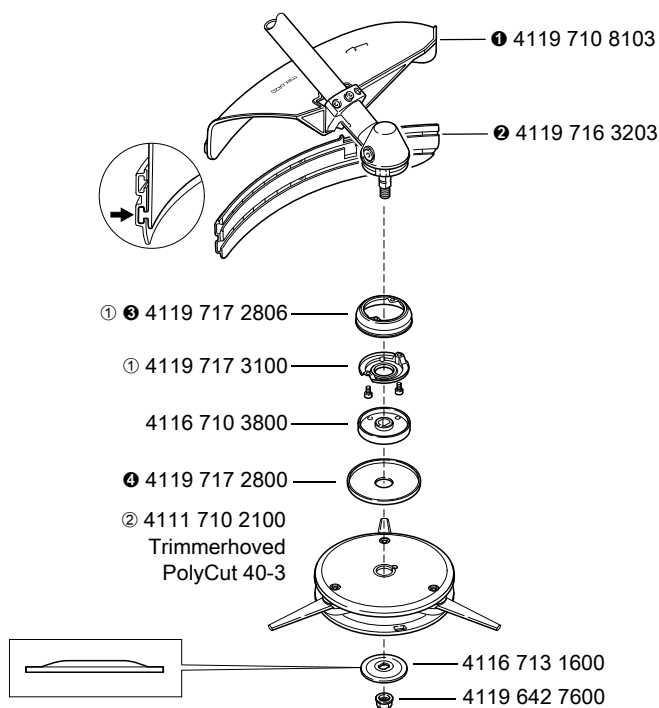

681KT512 KN

① Kun til drev med påskruet beskyttelsesring

② Leveres ikke længere

① + ② = 4119 007 1027

③ + ④ = 4119 007 1021

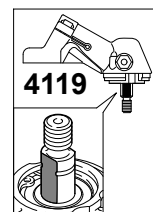
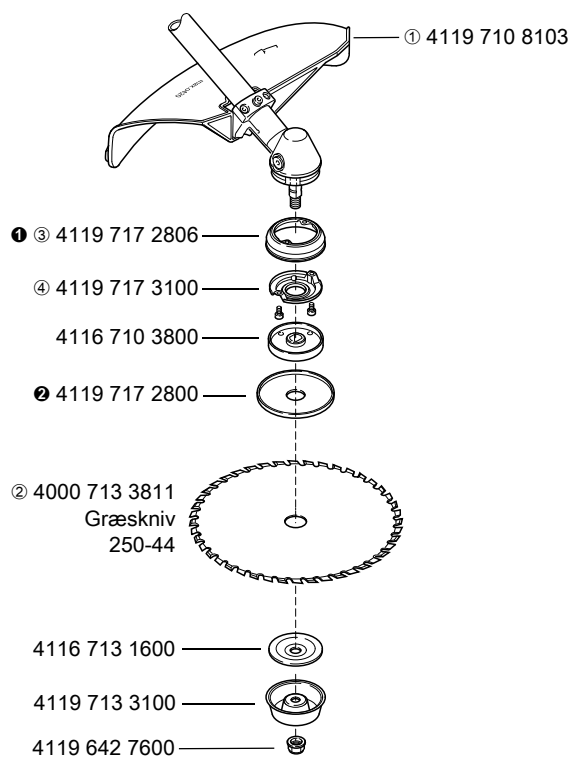

681KT1102 KN

① Beskyttelse til AUS, NZ, se billedet med "AUS, NZ"

② Ikke tilladt på trimmere med specialhåndtag

③ un til drev med påskruet beskyttelsesring

① + ② = 4119 007 1021

AUS NZ

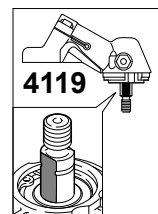
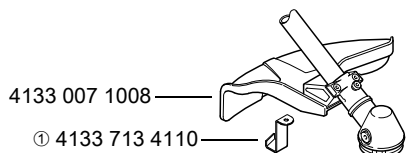

② 4000 713 3802
Græskniv
255-8

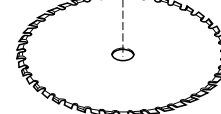
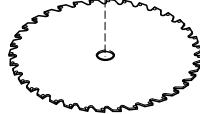
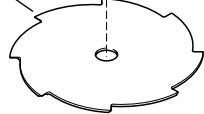
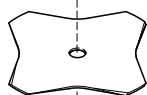
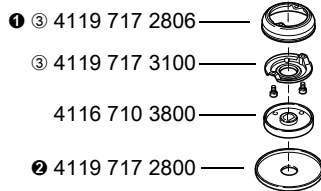

② 4000 713 3801
Græskniv
230-4

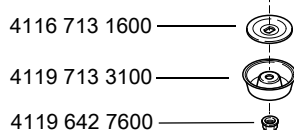

② 4000 713 3806
Græskniv
250-40

② 4001 713 3811
Græskniv
250-44

68IKT1120 KN

- ① Denne del er inkluderet i beskyttelsen
 - ② Ikke tilladt på trimmere med specialhåndtag
 - ③ Kun til drev med påskruet beskyttelsesring
- ① + ② = 4119 007 1021

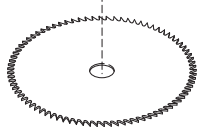
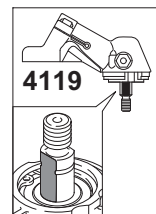
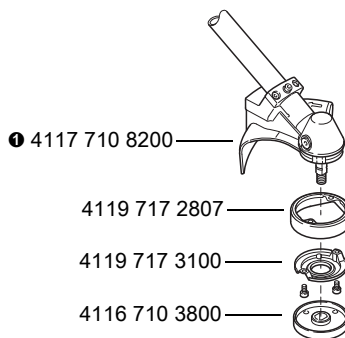

① 4000 713 4200
Rundsavsklinge
200-44, spidstandet

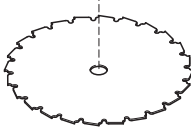

① 4119 713 4200
Rundsavsklinge
200-22, mejseltandet

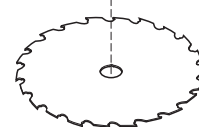

① 4000 713 4203
Rundsavsklinge
200-20 HP, mejseltandet

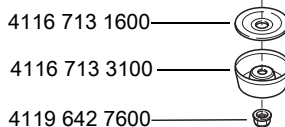

0000-GXX-5710-A0

- ① Ikke tilladt på trimmere med specialhåndtag
- ① + transportbeskyttelse = 4126 007 1002

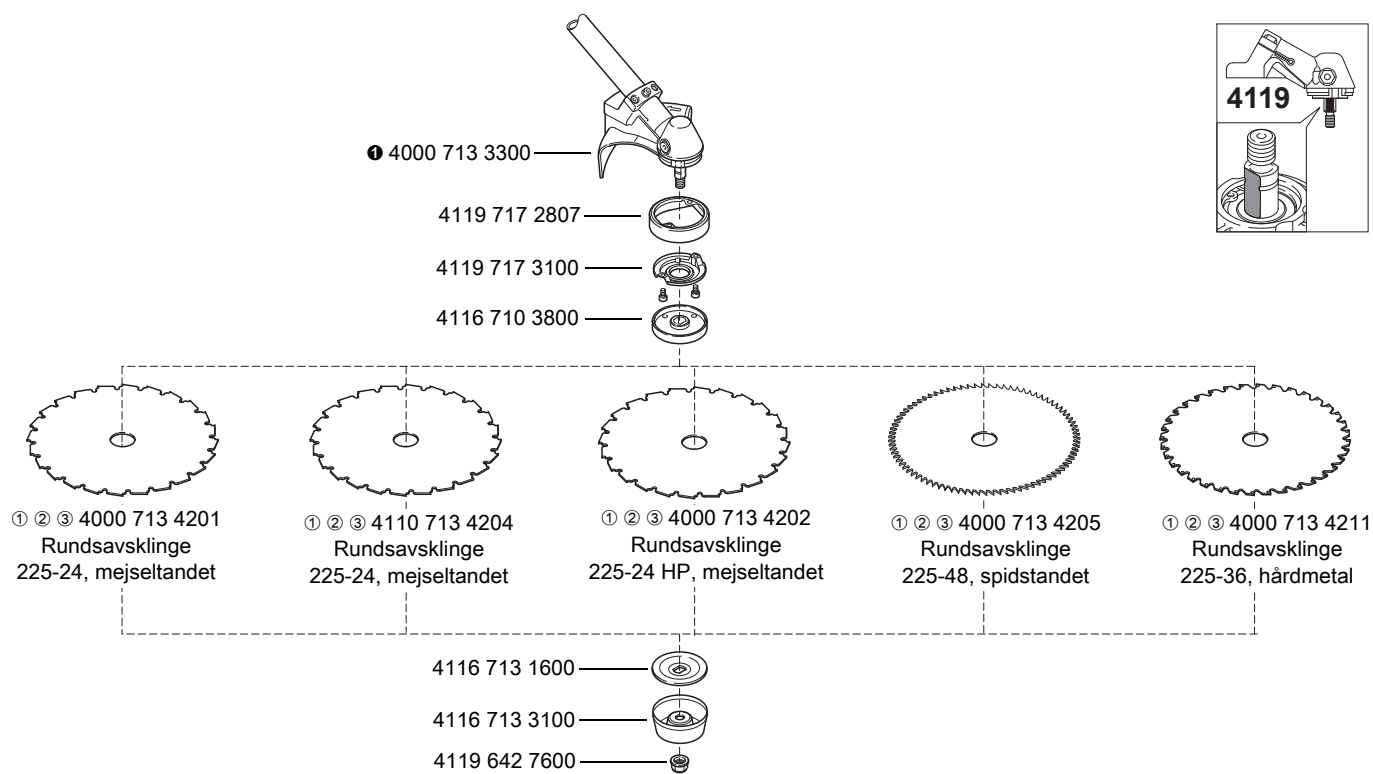

681KT870-A1

① Ikke tilladt til FS 300, 350

① + Transportsbeskyttelse = 4119 007 1009

② Tilladt i Brasilien fra 2014

③ Ikke tilladt på trimmere med specialhåndtag

(a) FS 260 R, 460 R: side 67 (b) fra 2010 (c) FS 410 K, 460 K, 490 K: side 91

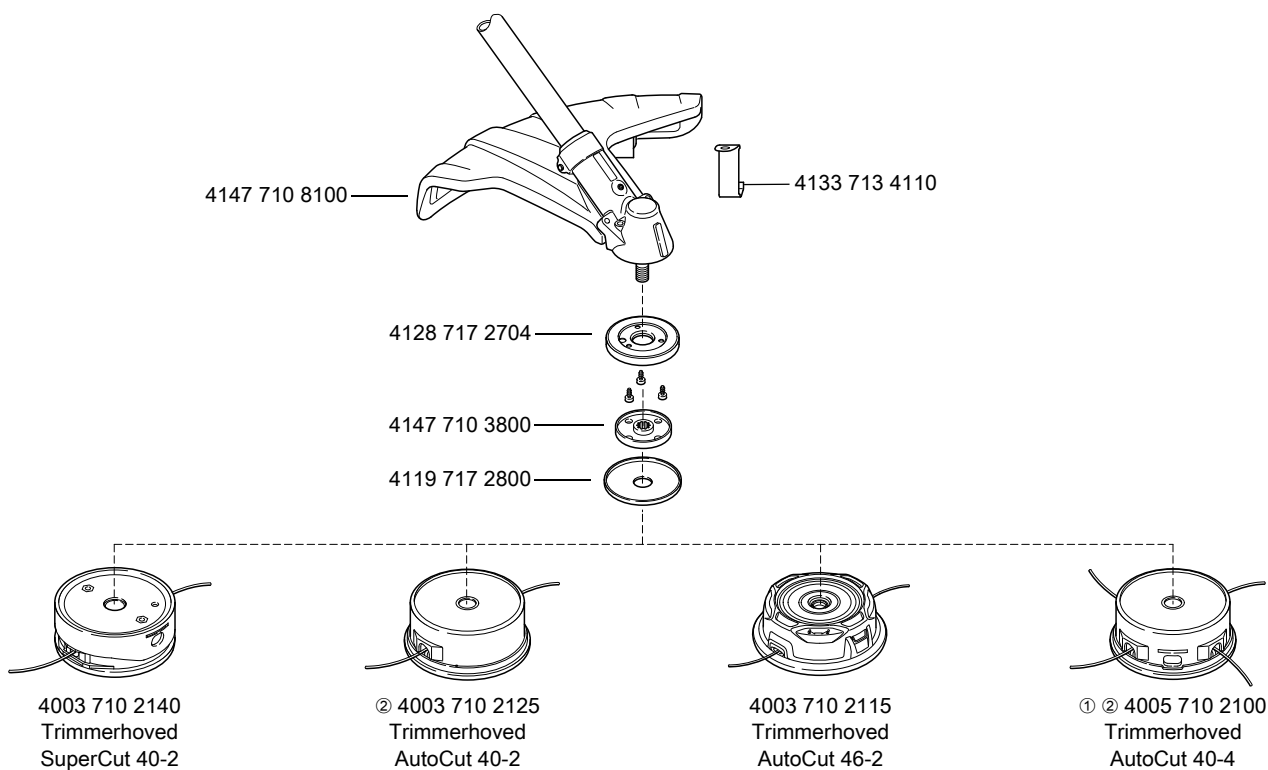

681KT1084 KN

① Ikke tilladt til FS 260, 311, 360, 410

② Leveres ikke længere

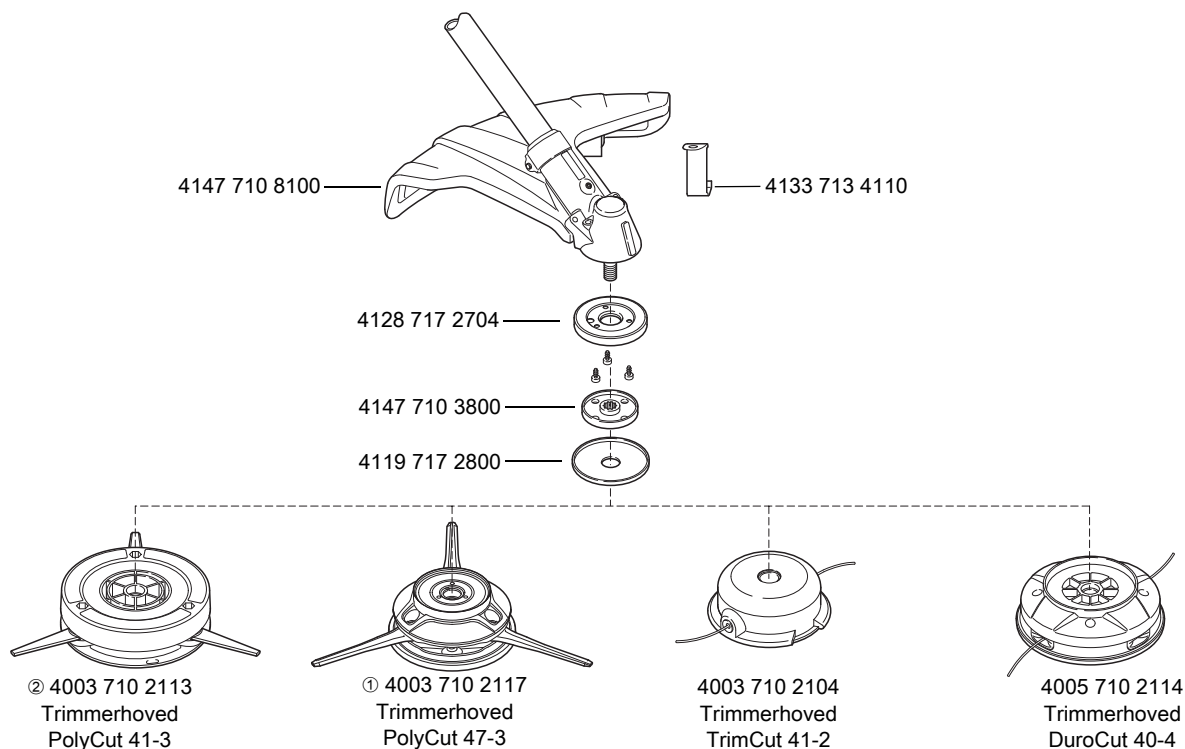

3000-GXX-5743-A0

① Ikke tilladt til FS 260, 410

② Leveres ikke længere

(a) FS 260 R, 460 R: side 67 (b) fra 2010 (c) FS 410 K, 460 K, 490 K: side 91

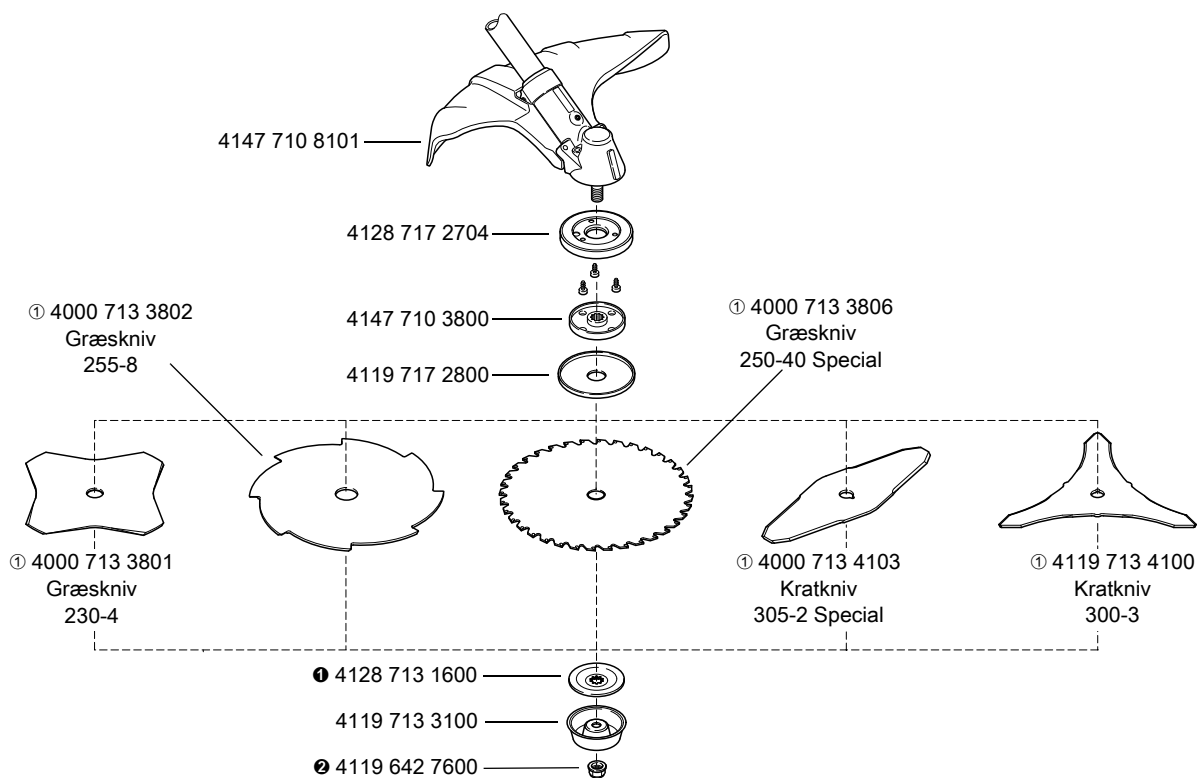

681KT805 KN

① Ikke tilladt på trimmere med specialhåndtag

① + ② = 4147 007 1014

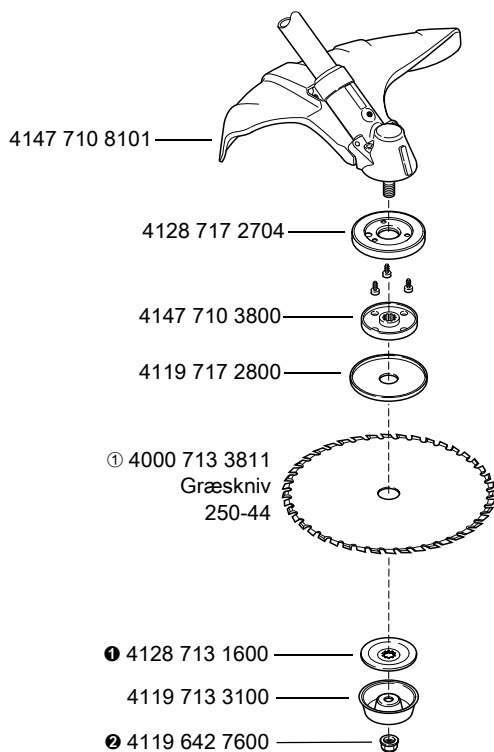

681KT1085 KN

① Ikke tilladt på trimmere med specialhåndtag

① + ② = 4147 007 1014

(a) FS 260 R, 460 R: side 67 (b) fra 2010 (c) FS 410 K, 460 K, 490 K: side 91

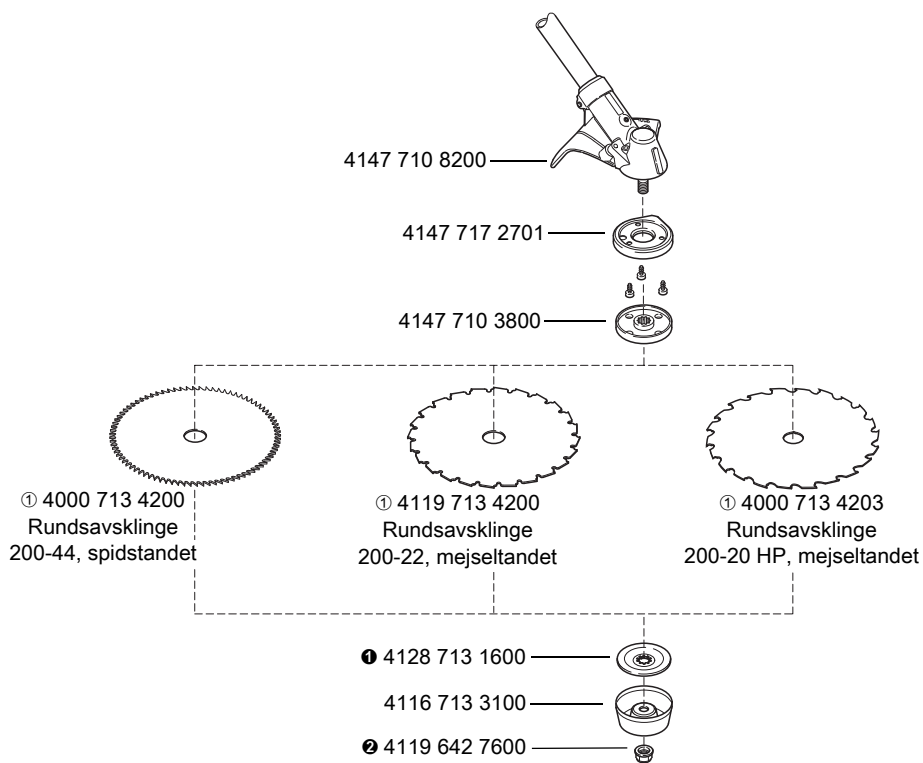

0000-GXX-5711-A0

① Ikke tilladt på trimmere med specialhåndtag

❶ + ❷ = 4147 007 1014

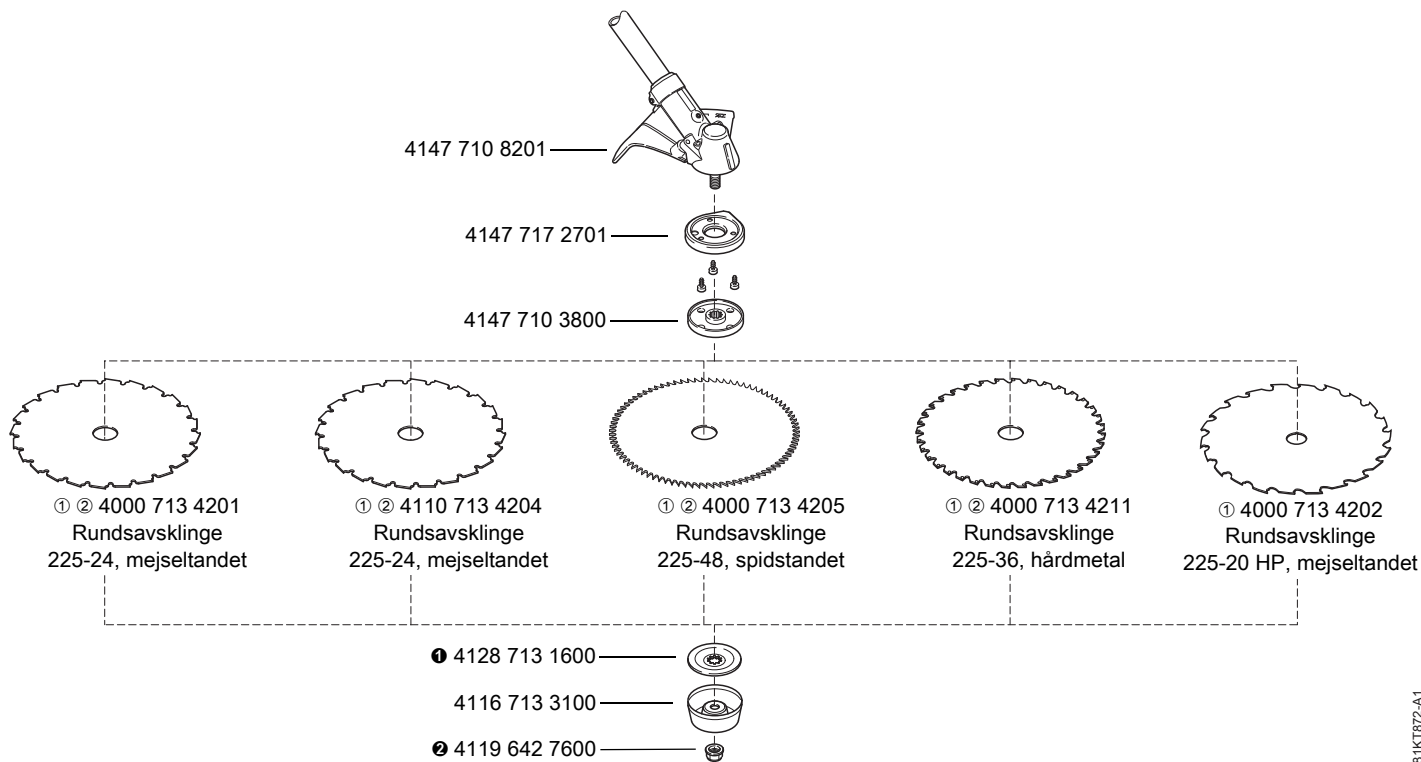

681KT872-A1

① Ikke tilladt på trimmere med specialhåndtag

❷ Ikke tilladt til FS 311

❶ + ❷ = 4147 007 1014

(a) FS 260 R, 460 R: side 67 (b) fra 2010 (c) FS 410 K, 460 K, 490 K: side 91

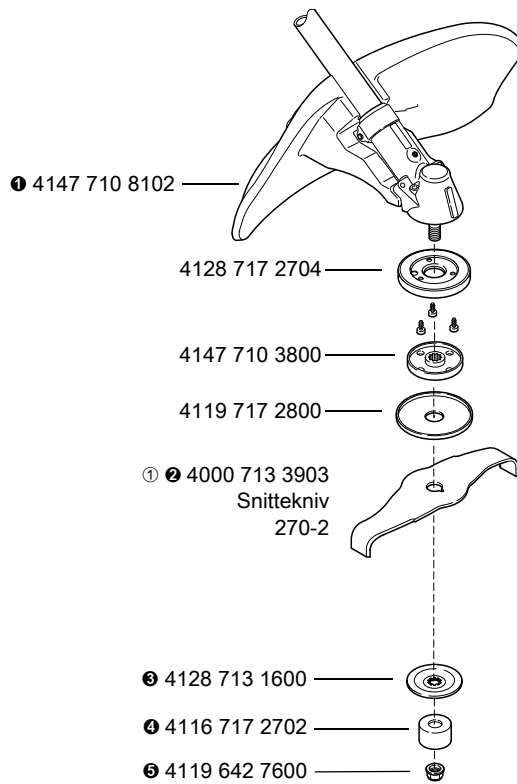

681KTB11 KN

❶ Ikke tilladt på trimmere med specialhåndtag

❶ + ❷ + ❸ = 4147 007 1011

❹ + ❺ = 4147 007 1014

(a) indtil 1987

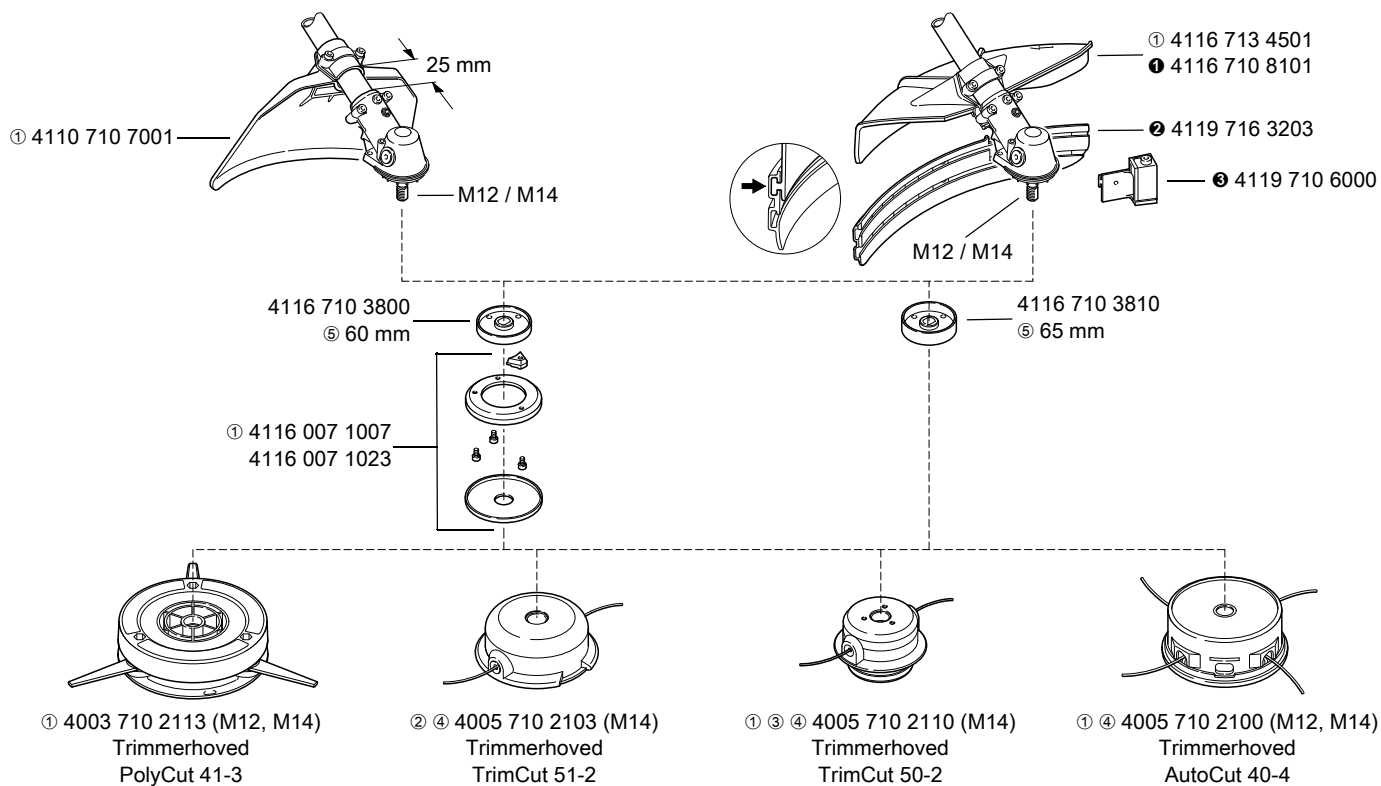

681KT533 KN

① Leveres ikke længere

② Til M12: 4003 710 2104 TrimCut 41-2

③ Til M12: 4003 710 2101 TrimCut 40-2

④ Anvend støjsvag trimmertråd inden for EU

⑤ diameter

① + ② + ③ = 4116 007 1016

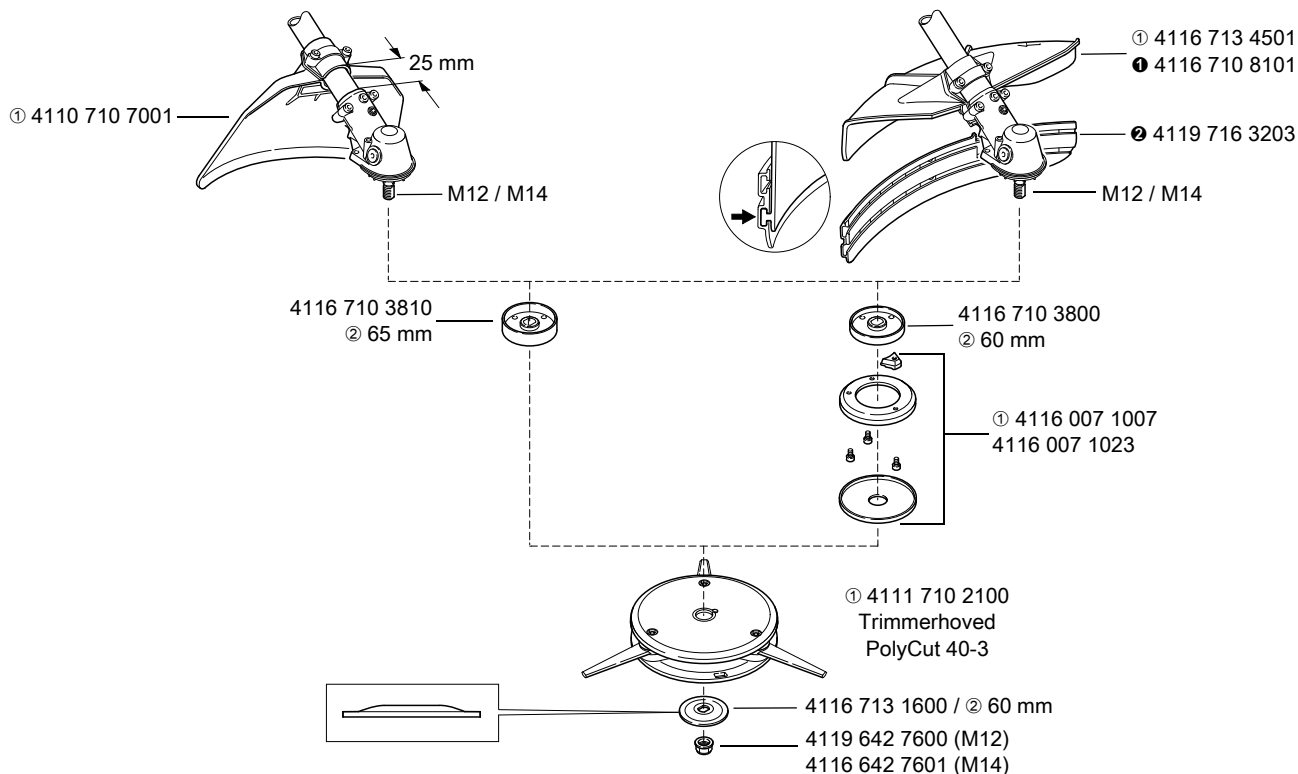

681KT814 KN

① Leveres ikke længere

② Diameter

① + ② = 4116 007 1016

(a) indtil 1987

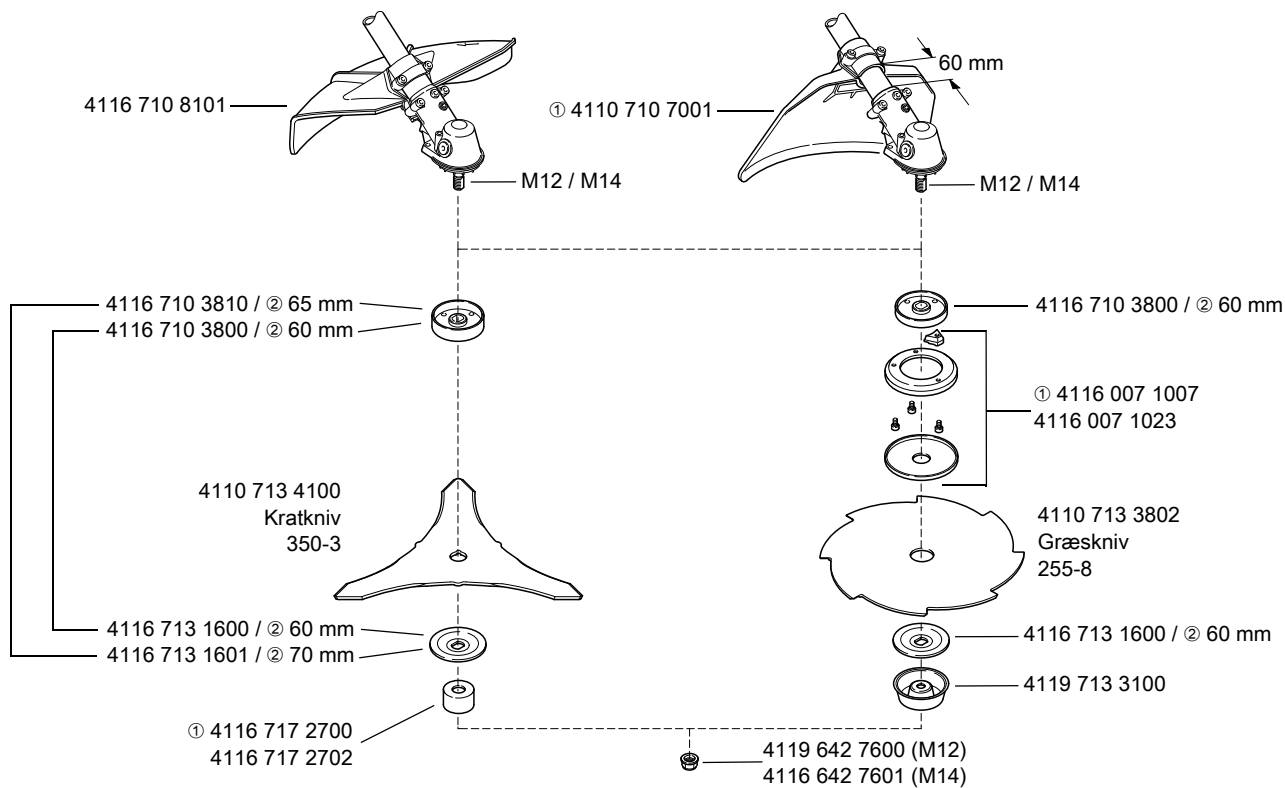

681KT534 KN

① Leveres ikke længere

② Diameter

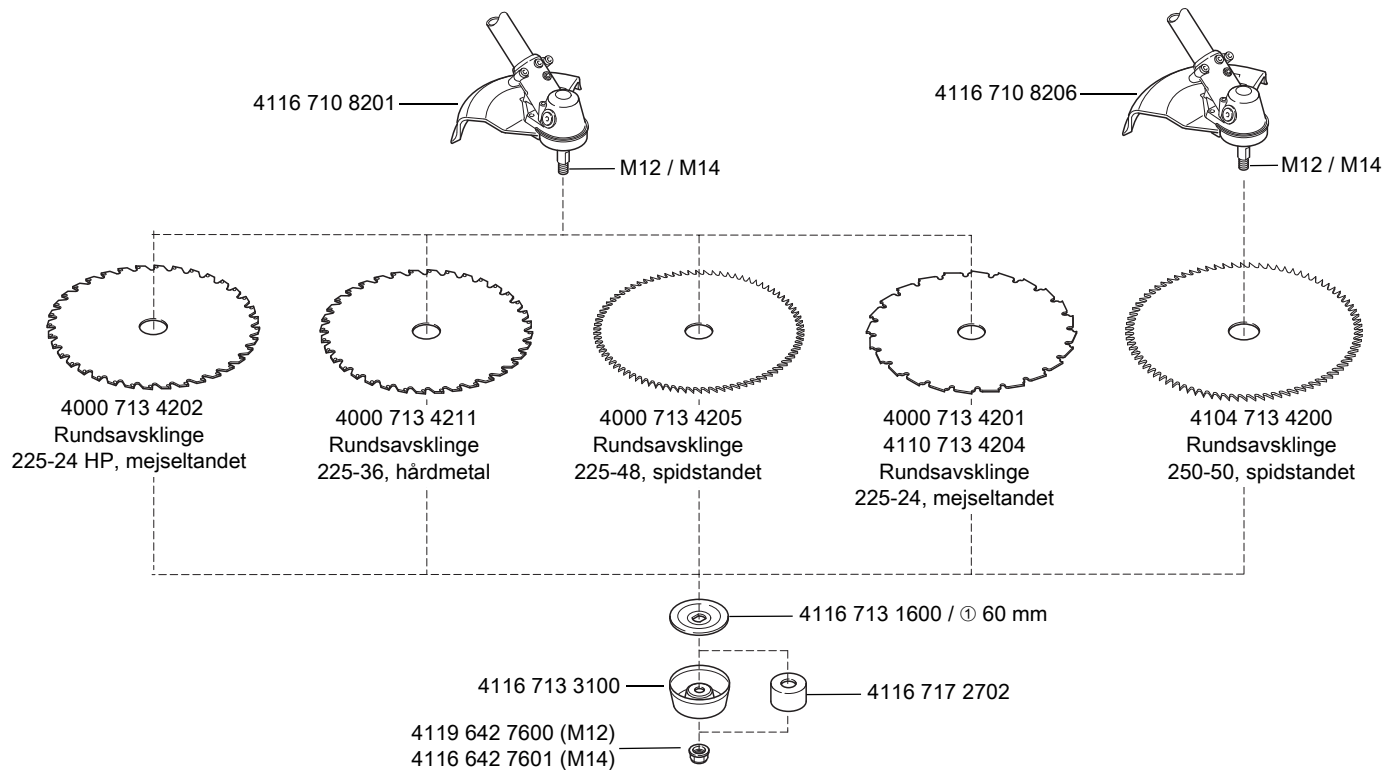

0000-GXX-5712-A0

① Diameter

(a) fra 2010 (b) FS 410, 460, 490: side 85 (c) FS 460 R: side 67

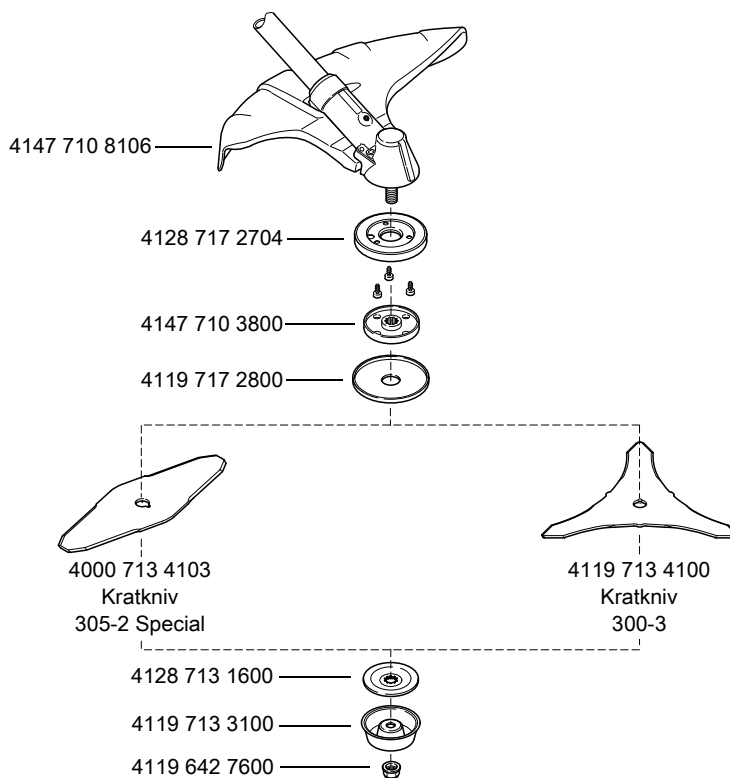

681KT813 KN

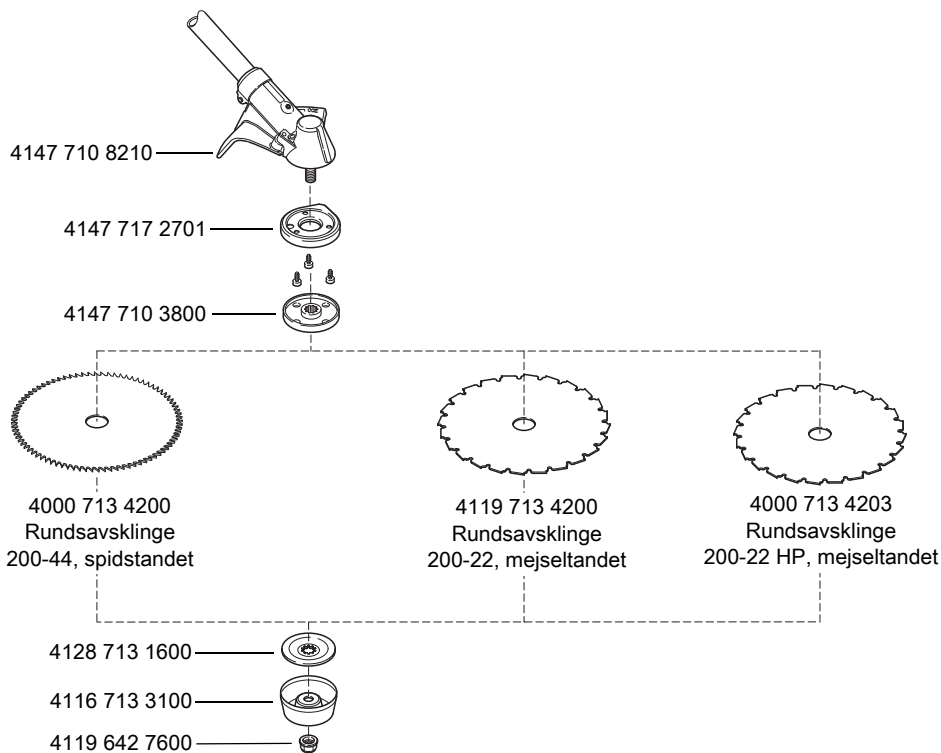

381KT513-A1

(a) fra 2010 (b) FS 410, 460, 490: side 85 (c) FS 460 R: side 67

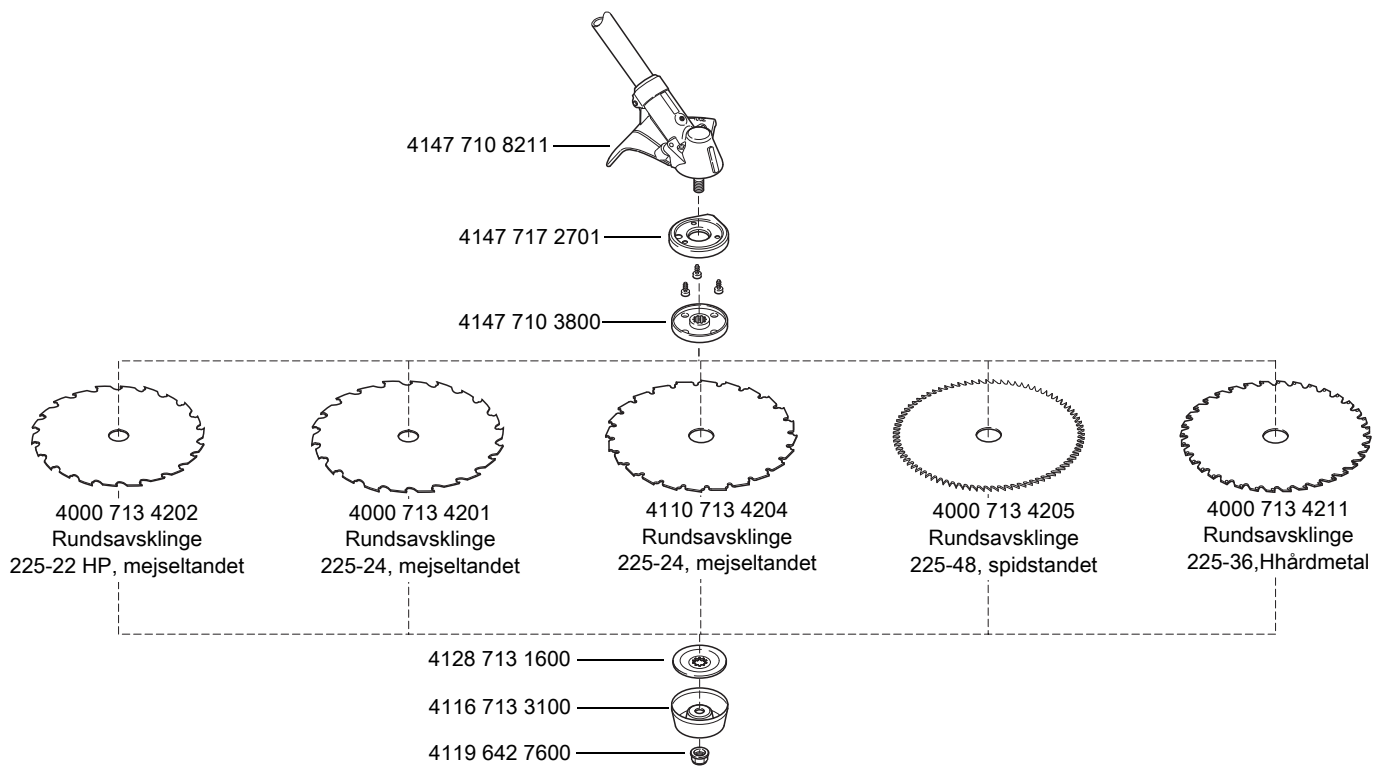

0000-GXX-5713-A0

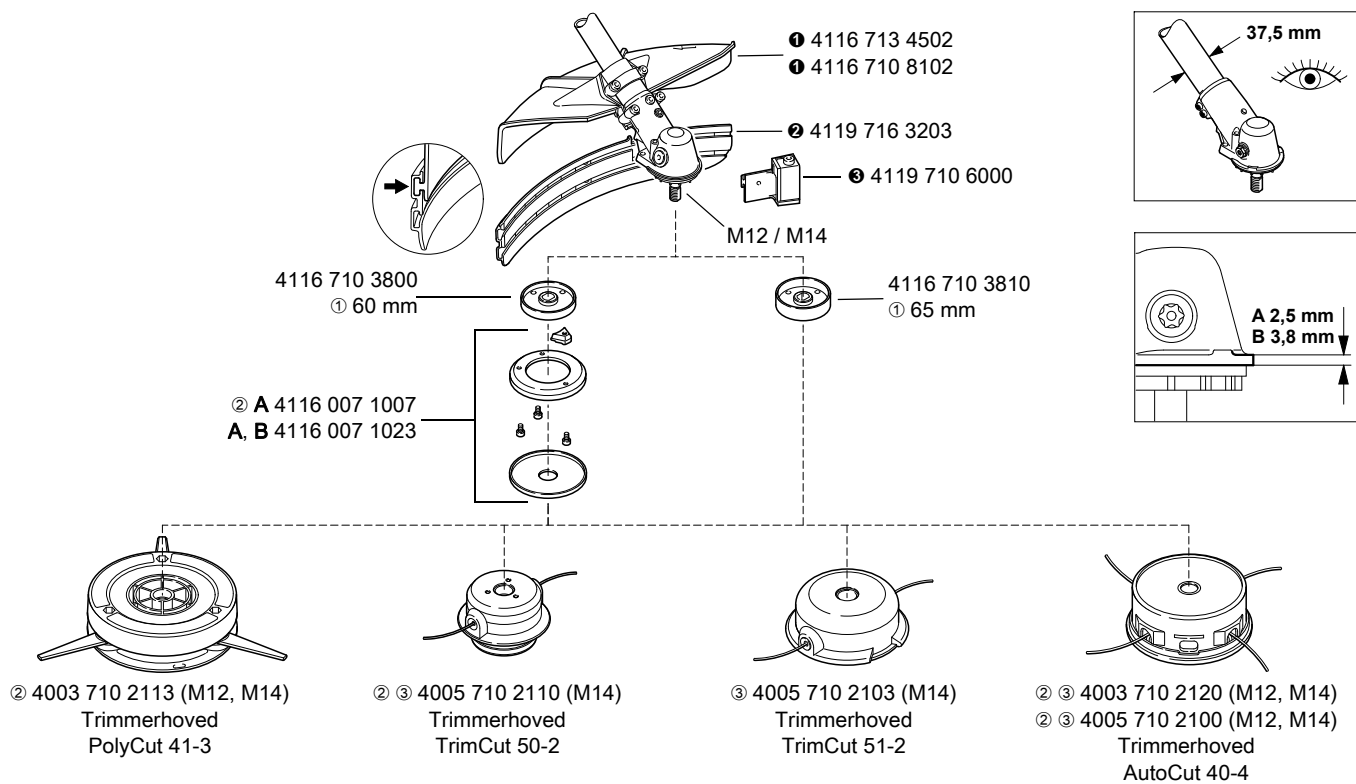

681KT566 KN

- ① Diameter
- ② Leveres ikke længere
- ③ Anvend støjsvag trimmertråd inden for EU
- ① + ② + ③ = 4116 007 1020

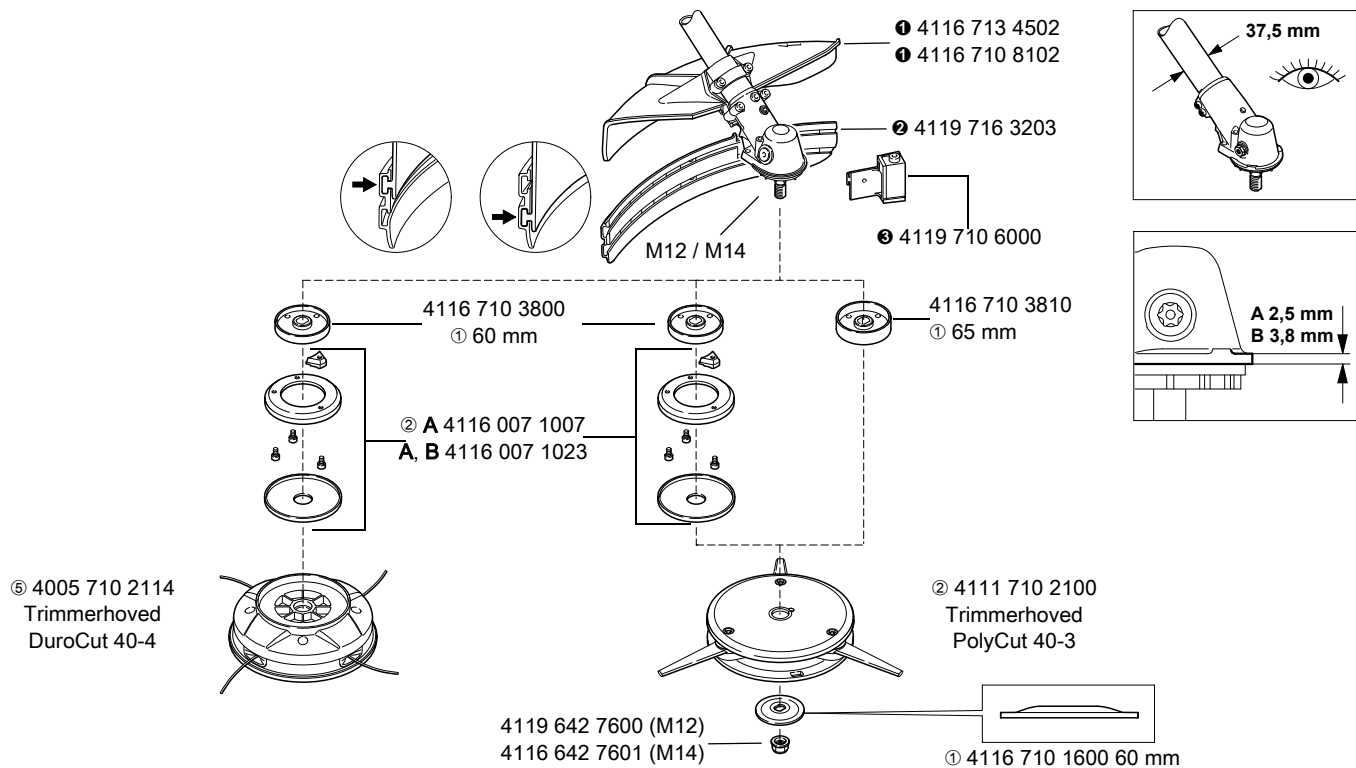

681KT816 KN

- ① Diameter
- ② Leveres ikke længere
- ③ Til DuroCut 40-4
- ④ Til PolyCut 40-3
- ⑤ Anvend støjsvag trimmertråd inden for EU
- ① + ② + ③ = 4116 007 1020

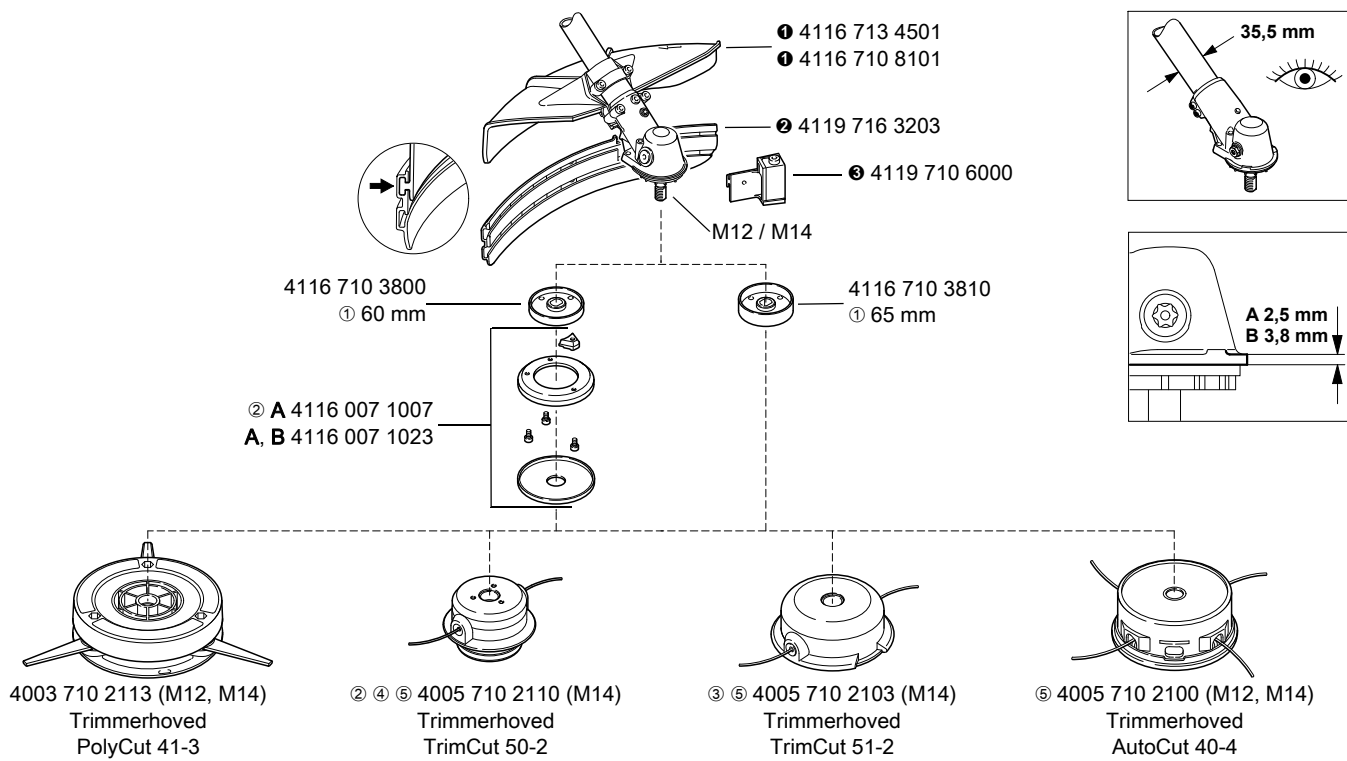

681KT817 KN

- ① Diameter
- ② Leveres ikke længere
- ③ Til M12: 4003 710 2104 TrimCut 41-2
- ④ Til M12: 4003 710 2101 TrimCut 40-2
- ⑤ Anvend støjsvag trimmertråd inden for EU
- 1 + 2 + 3 = 4116 710 1016**

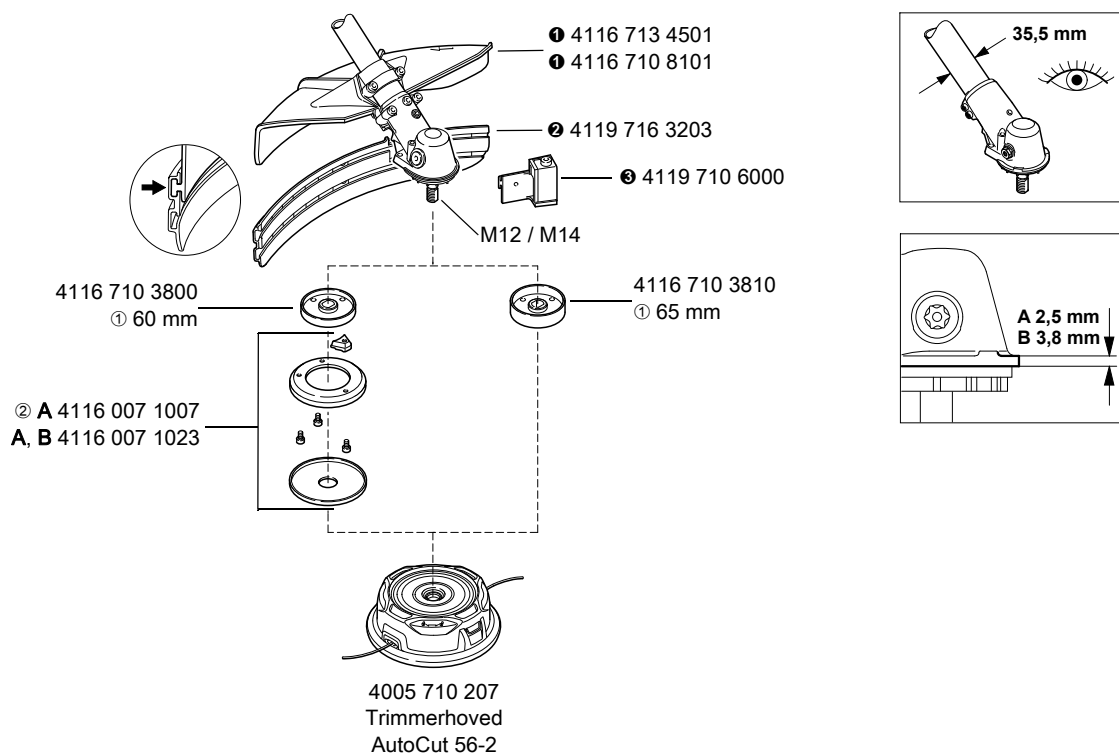

681KT1122 KN

- ① Diameter
- ② Leveres ikke længere
- 1 + 2 + 3 = 4116 710 1016**

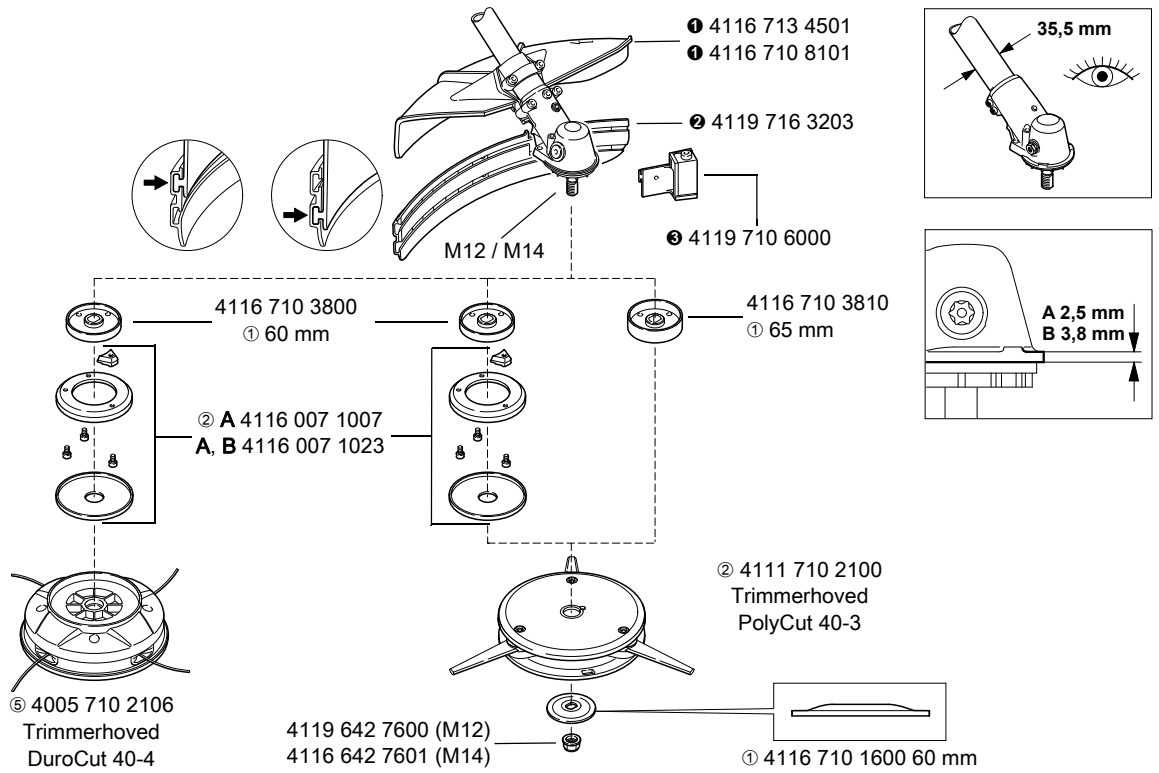

681KT18 KN

- ① Diameter
- ② Leveres ikke længere
- ③ Til DuroCut 40-4
- ④ Til PolyCut 40-3
- ⑤ Anvend støjsvag trimmertråd inden for EU
- 1 + 2 + 3 = 4116 710 1016**

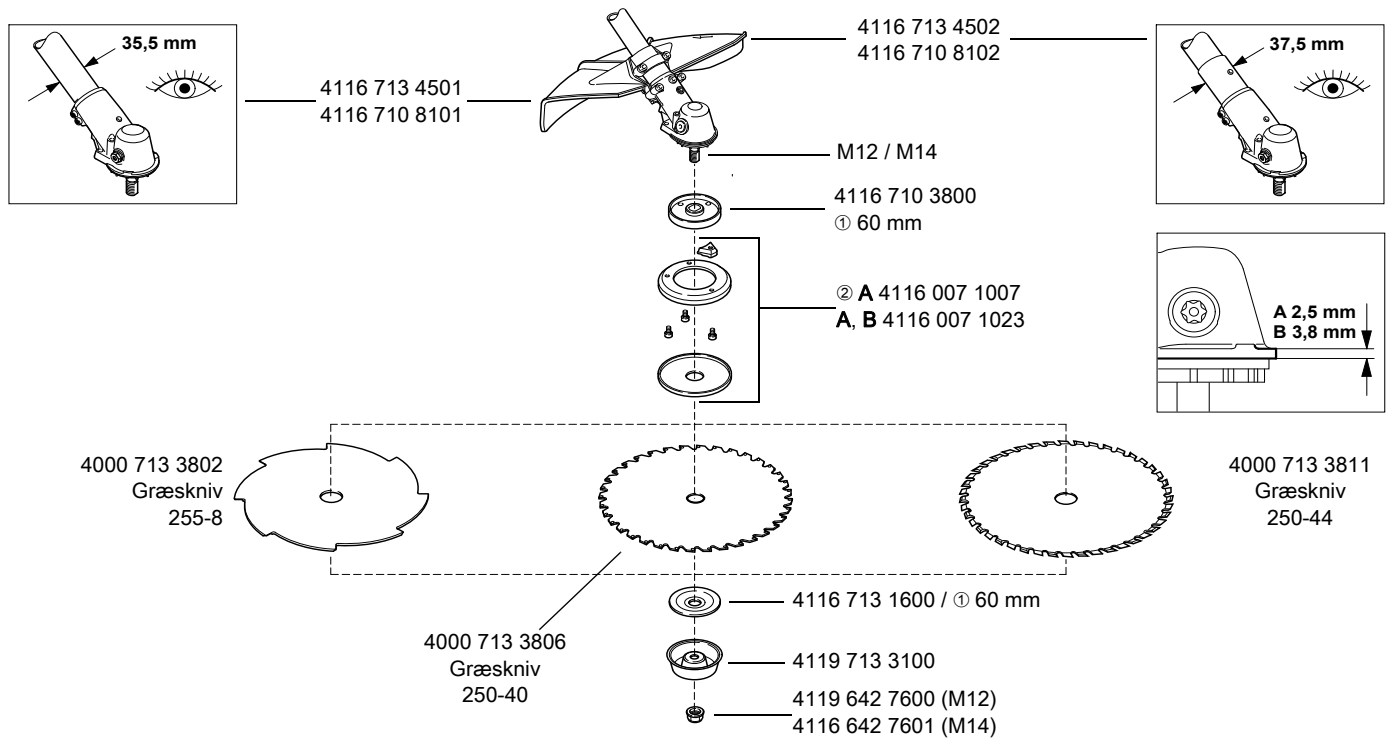

681KT1121 KN

- ① Diameter
- ② Leveres ikke længere

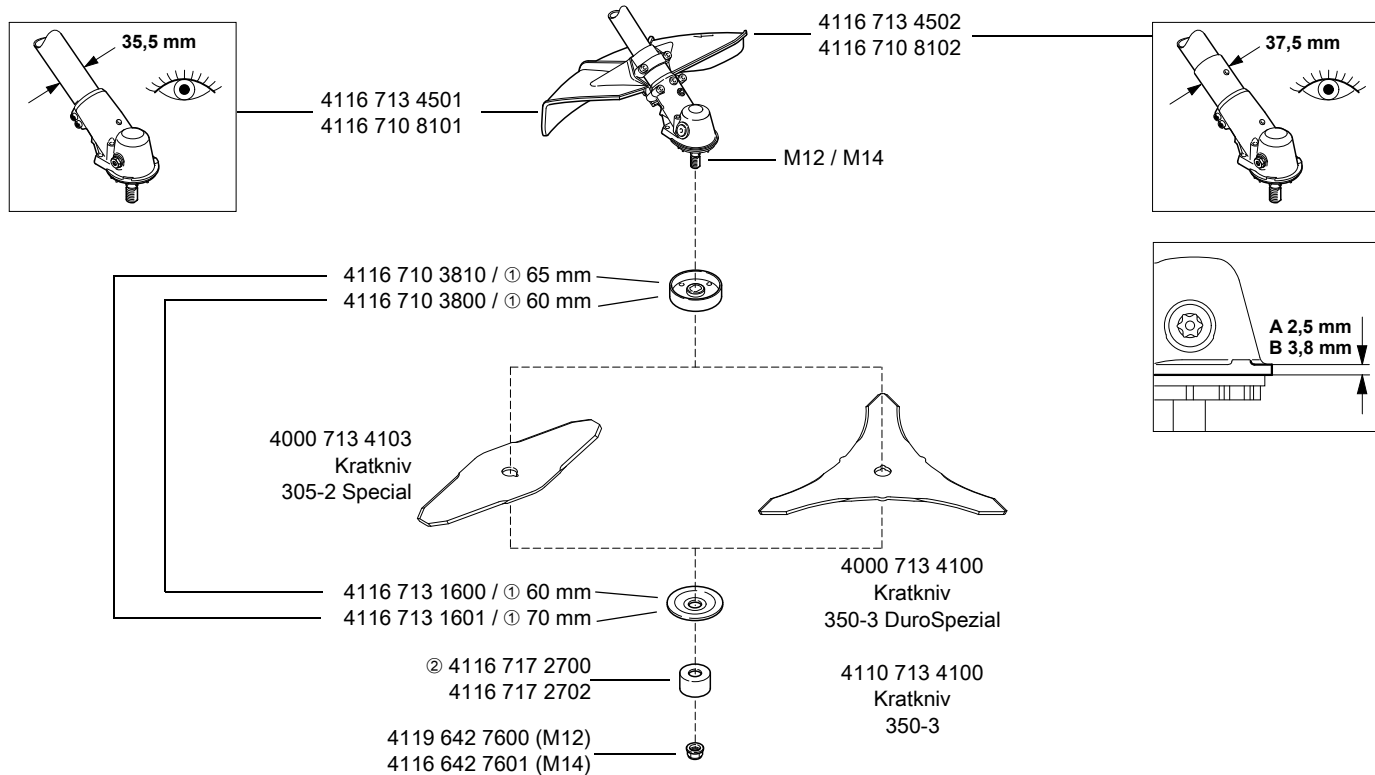

681KT579 KN

① Diameter

② Leveres ikke længere

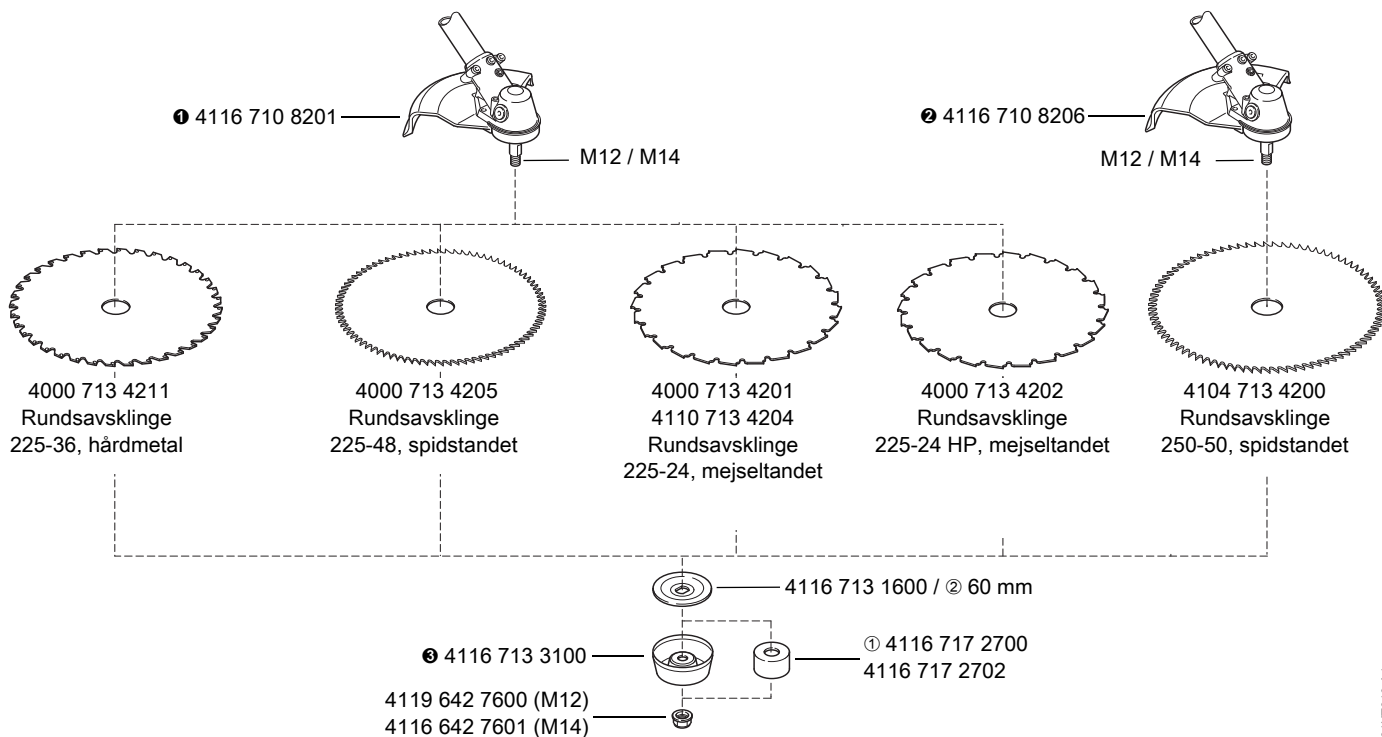

681KT819-A1

① Leveres ikke længere

② Diameter

① + ③ + Transportbeskyttelse = 4116 007 1019

② + ③ + transportbeskyttelse = 4116 007 1018

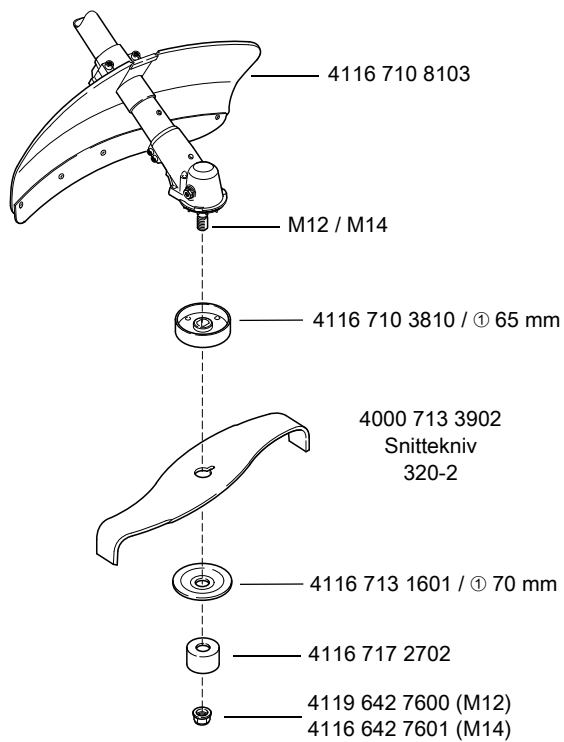

681KT560 KN

① Diameter

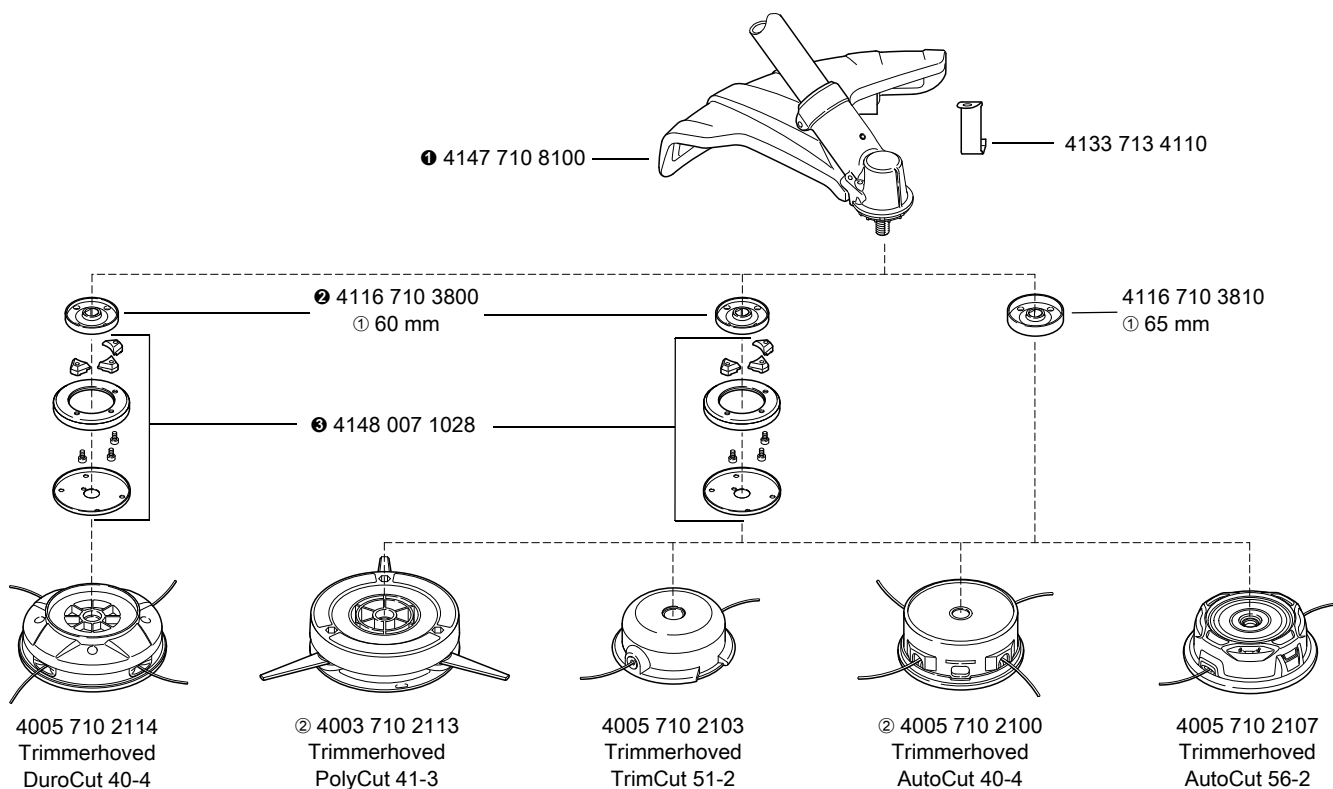

681KT1086 KN

① Diameter

② Leveres ikke længere

① + ② + ③ = 4148 007 1027

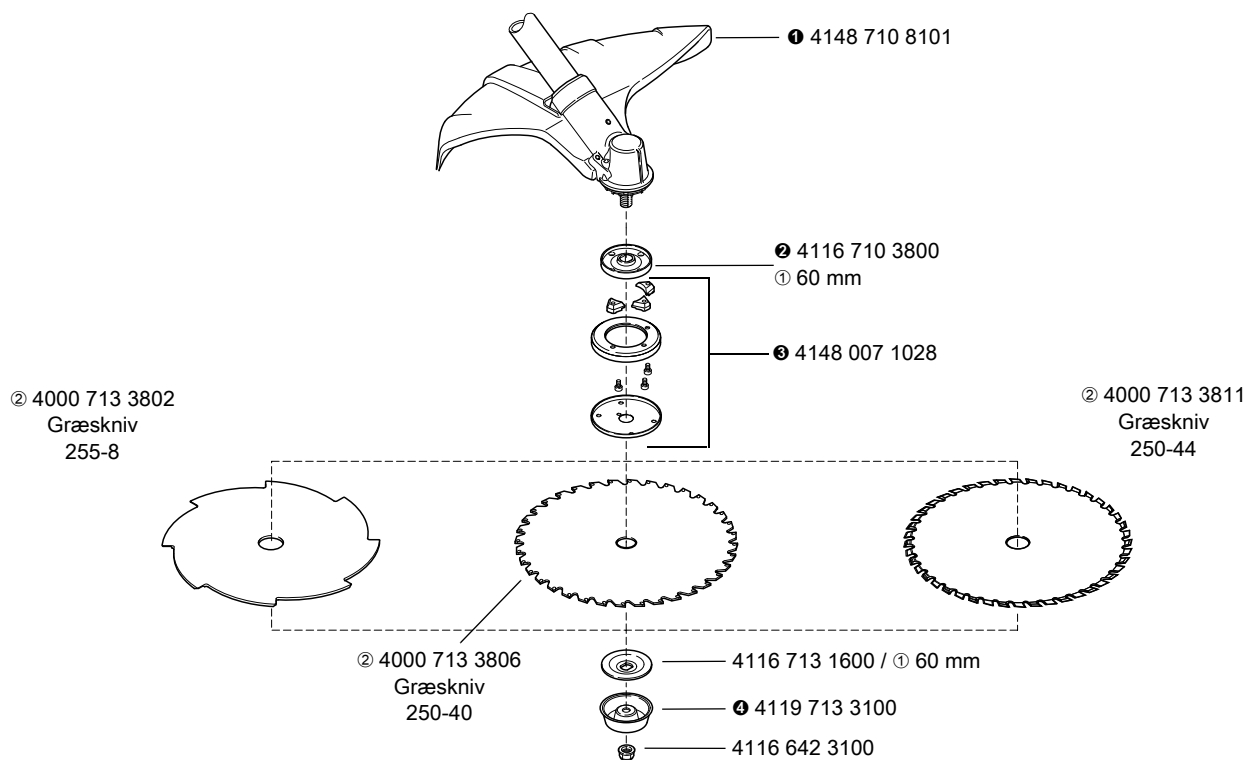

681KT1103 KN

① Diameter

② Ikke tilladt på trimmere med specialhåndtag

① + ② + ③ + ④ = 4148 007 1024

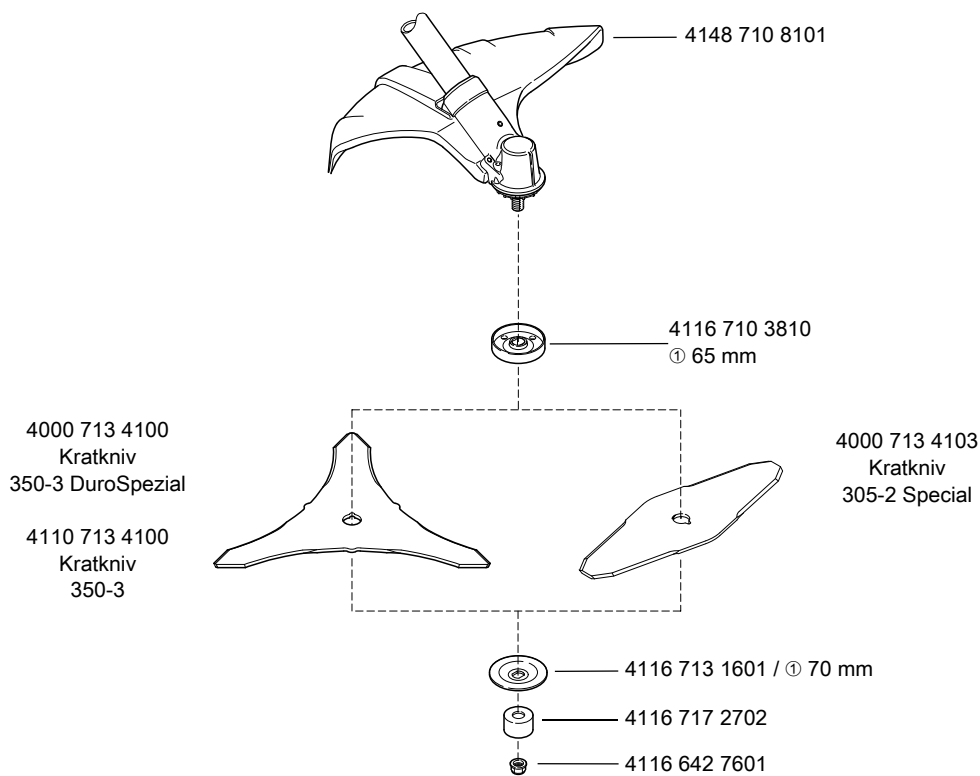

681KT906 KN

① Diameter

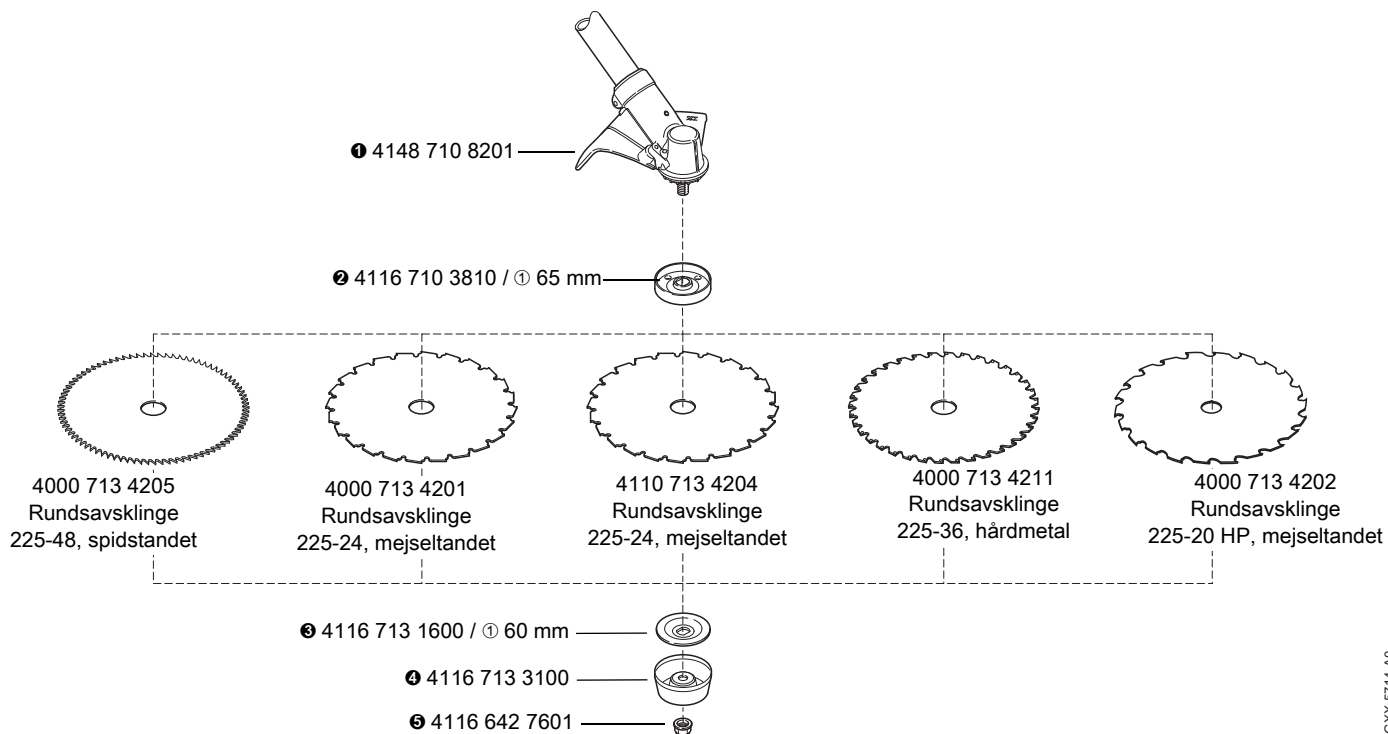

0000-G-XX-5714-A0

① Diameter

① + ② + ③ + ④ + ⑤ + Transportbeskyttelse = 4148 007 1022

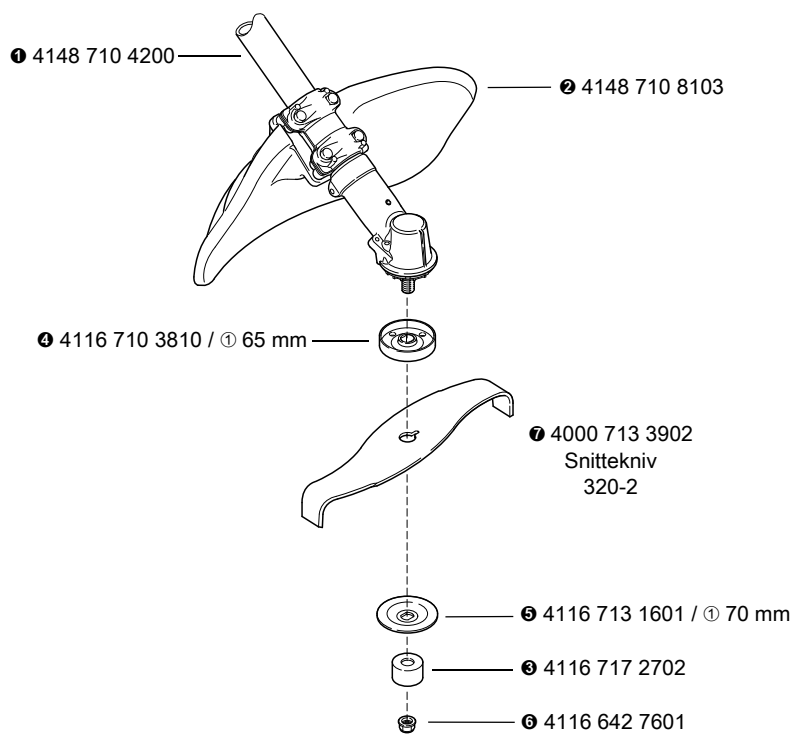

681KT653 KN

$\text{\textcircled{1}}$ Diameter

4 + 5 + 6 = 4148 007 1009

1 + 2 + 3 + 7 = 4148 007 1012

1 + 2 + 3 = 4148 007 1021

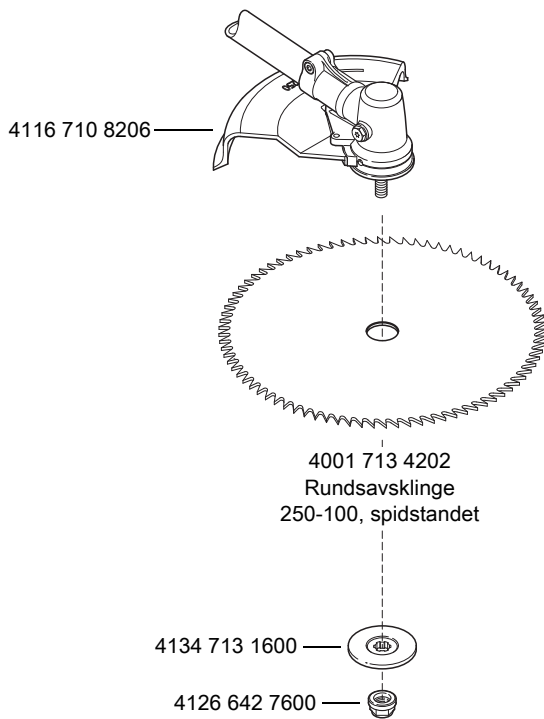

0000-GXX-8291-A0

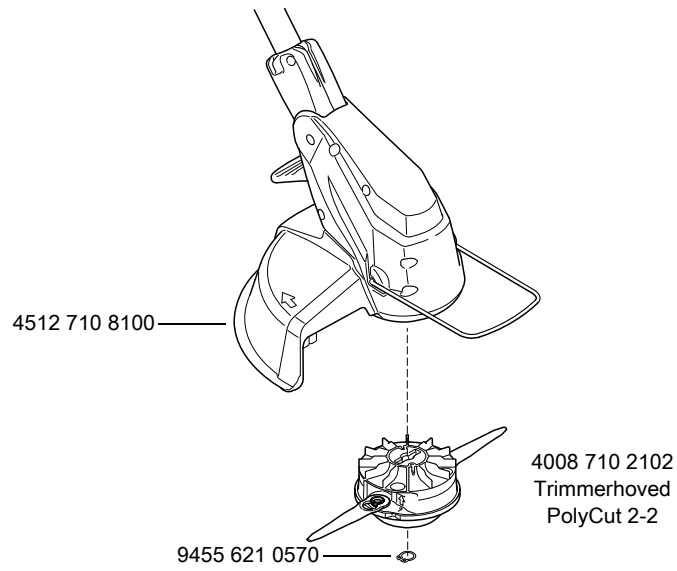

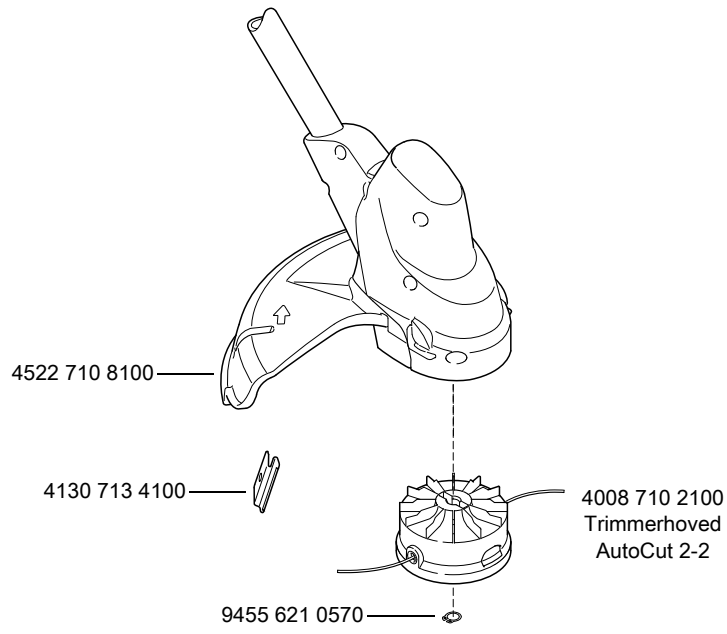

0000-GXX-3620-A0

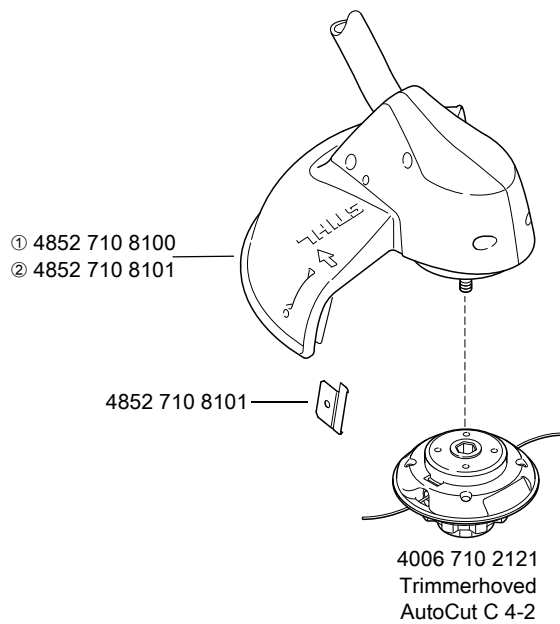

681KT806 KN

① FSA 65

② FSA 85

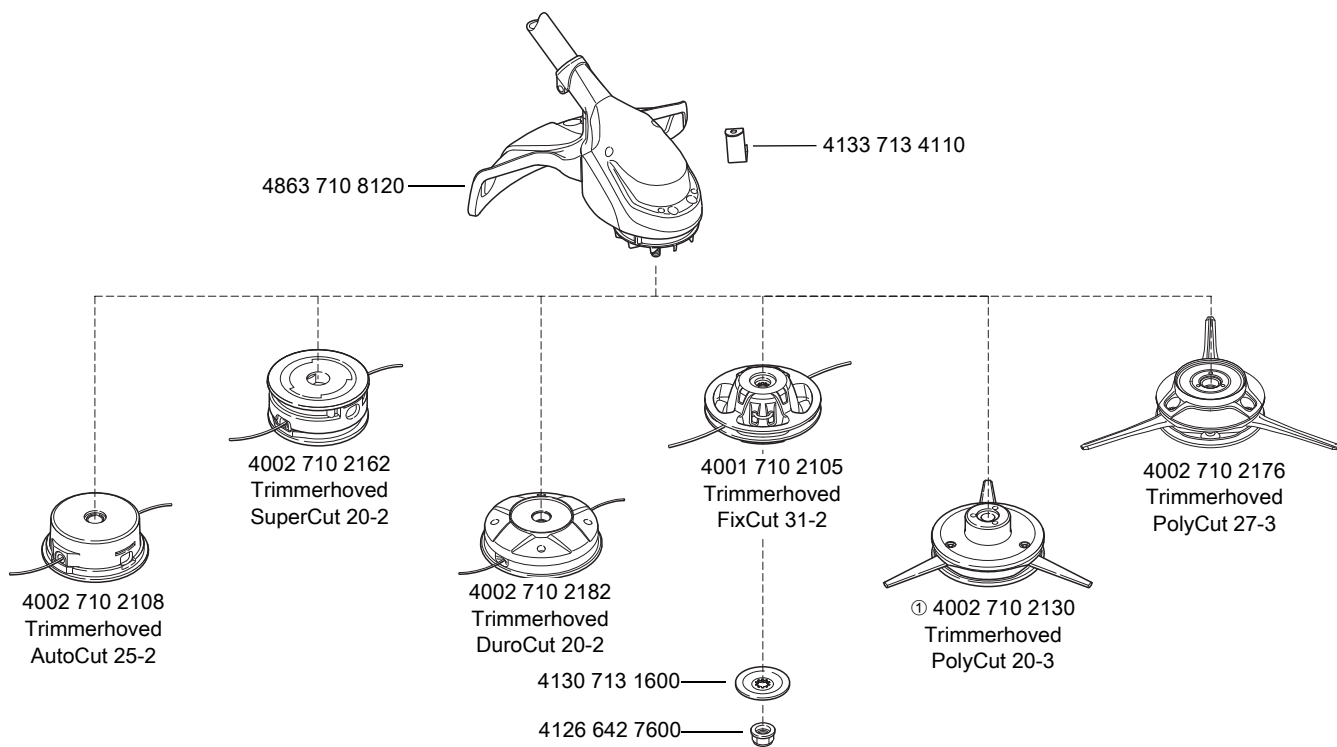

0000-GXX-5715-A0

① Leveres ikke længere

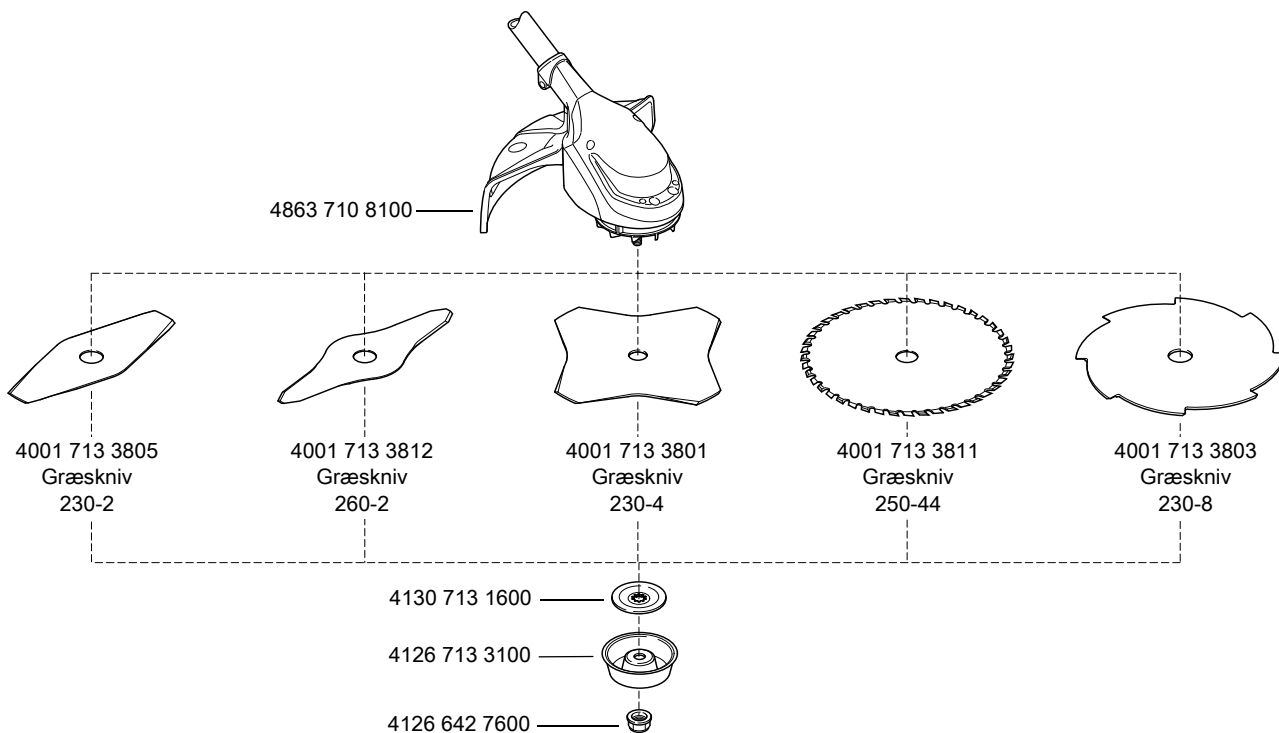

681KT1088 KN

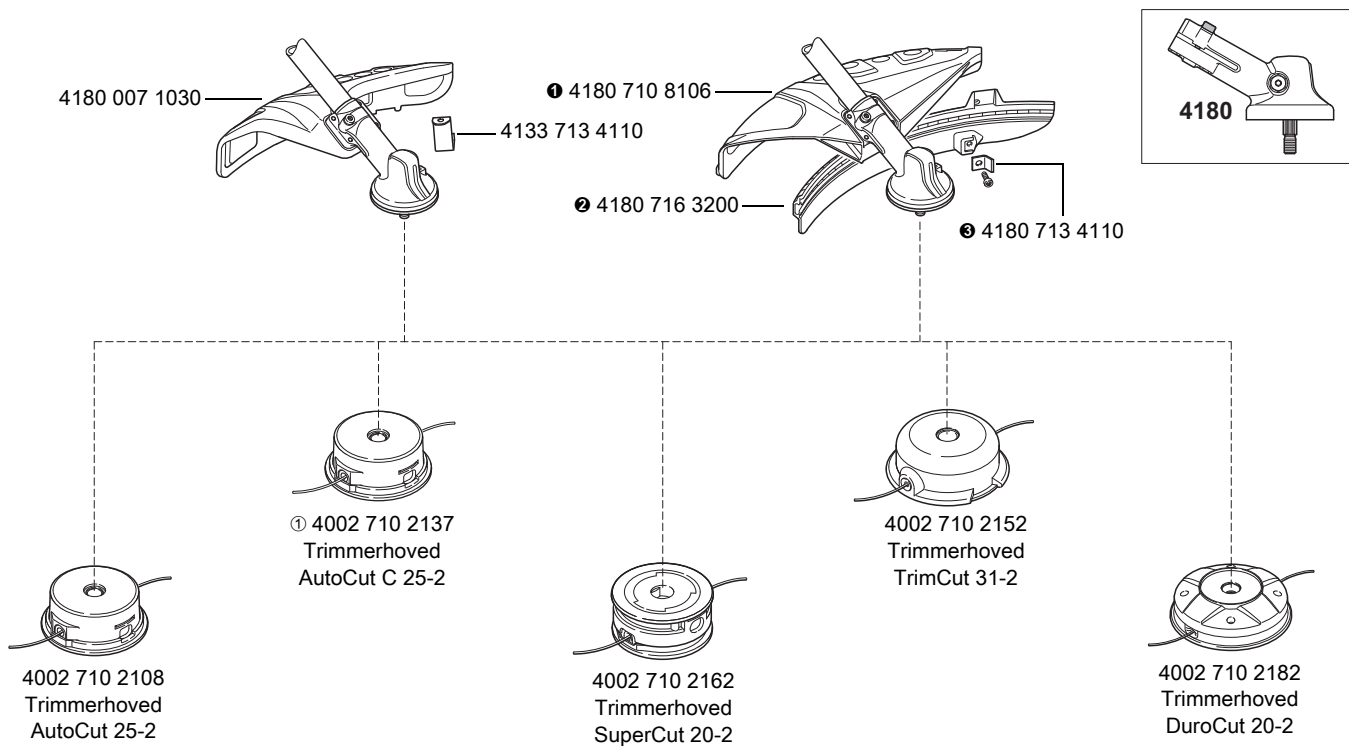

0000-GXX-5716-A0

① Leveres ikke længere

❶ + ❷ + ❸ = 4180 007 1028

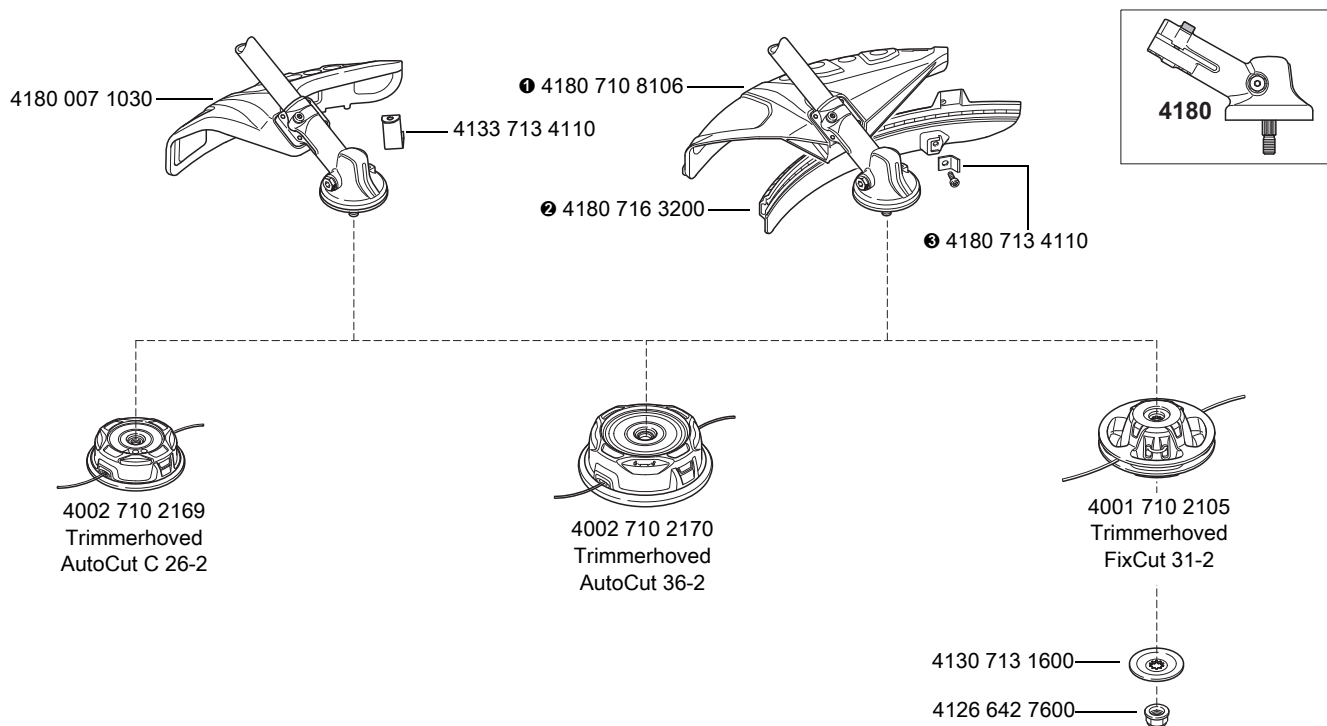

0000-GXX-5717-A0

① Leveres ikke længere

❶ + ❷ + ❸ = 4180 007 1028

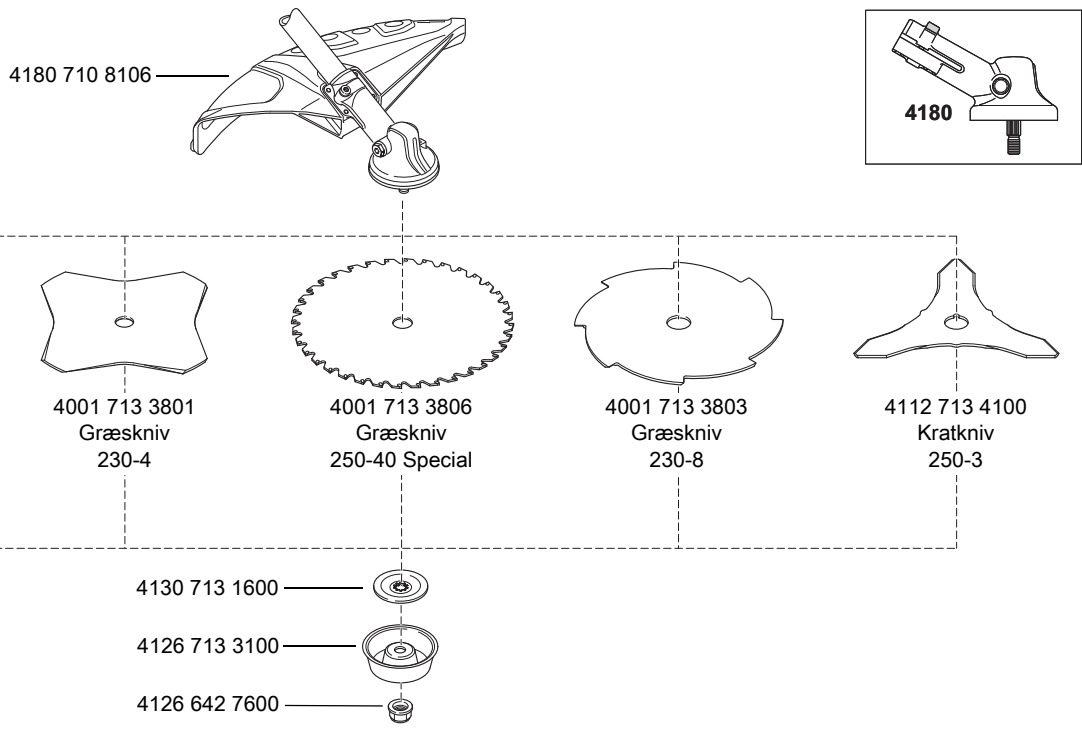

0000-GXX-3464-A0

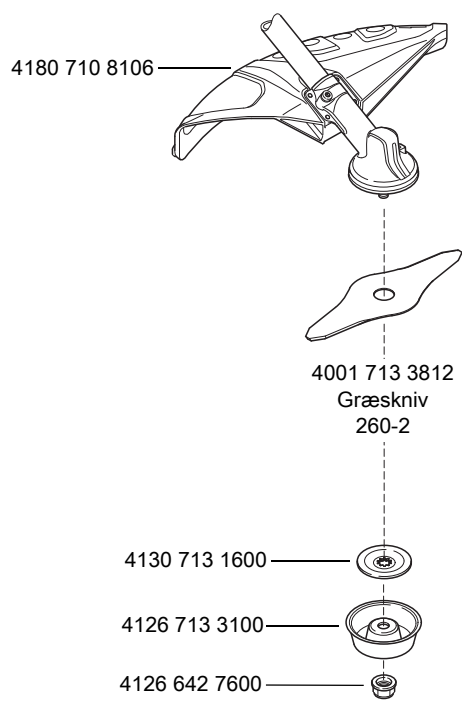

0000-GXX-5719-A0

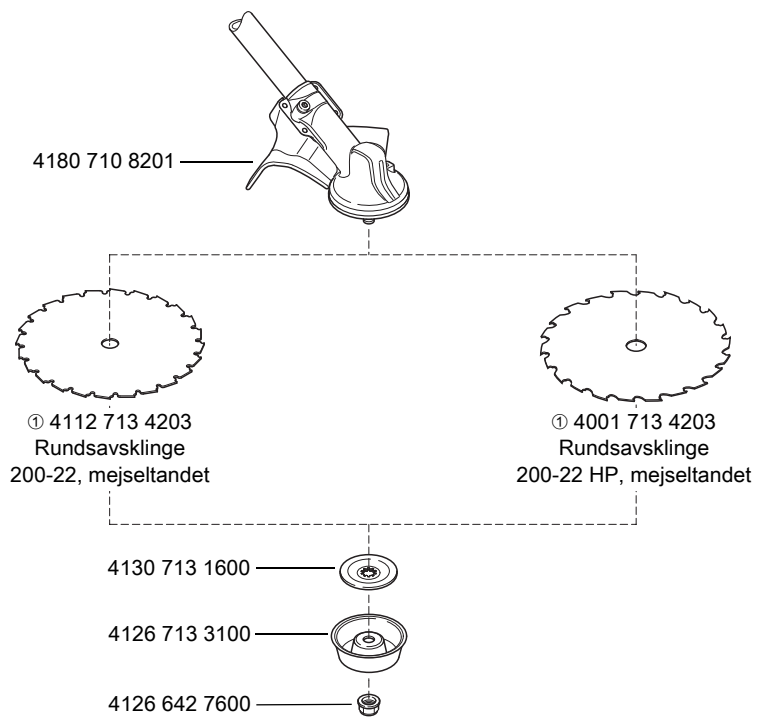

0000-GXX-5720-A0

① Ikke tilladt på trimmere med specialhåndtag

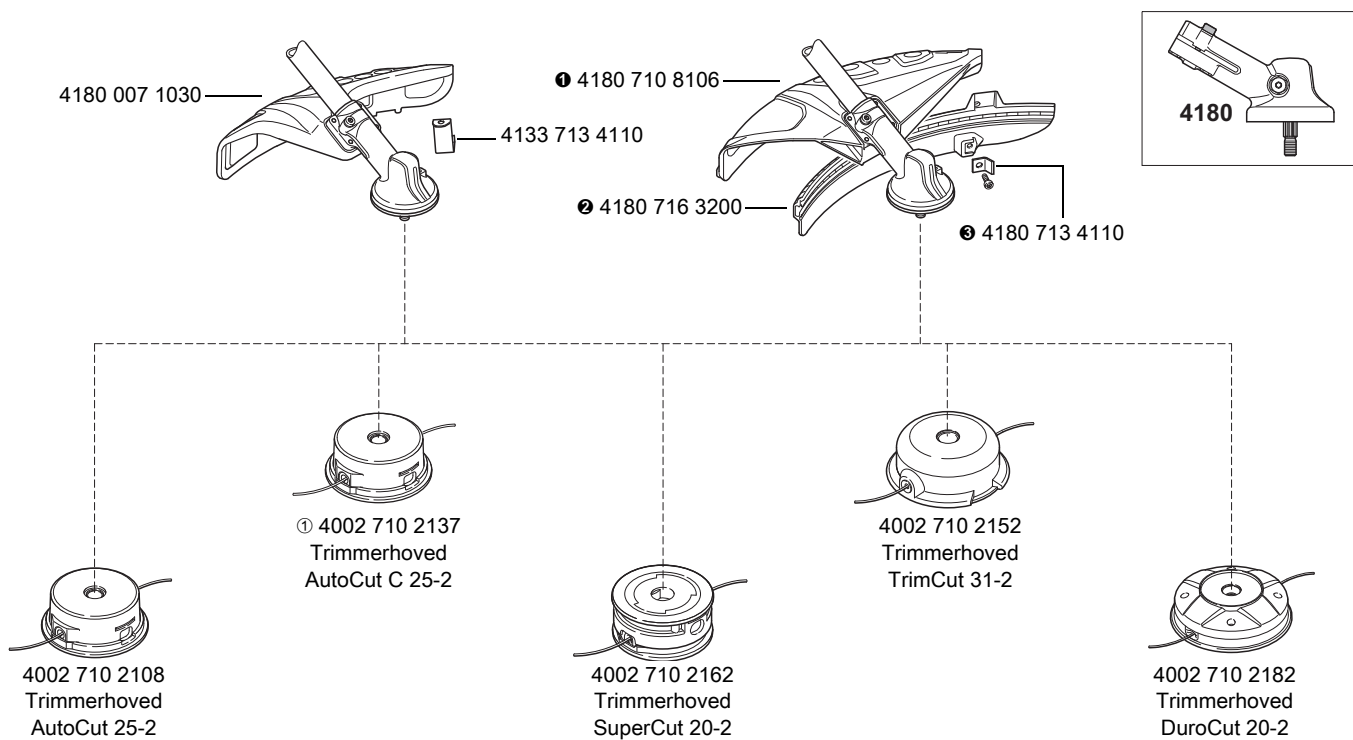

0000-GXX-5716-A0

① Leveres ikke længere

① + ② + ③ = 4180 007 1028

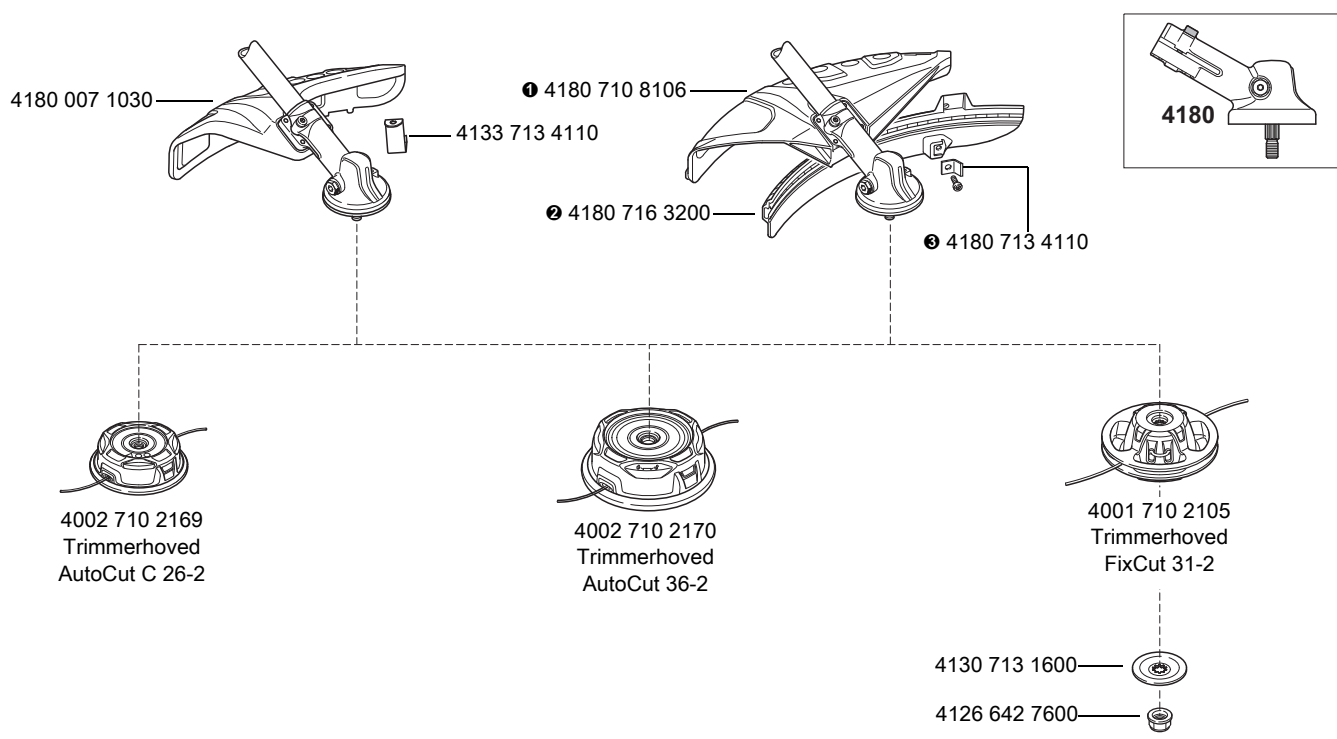

0000-GXX-5717-A0

① + ② + ③ = 4180 007 1028

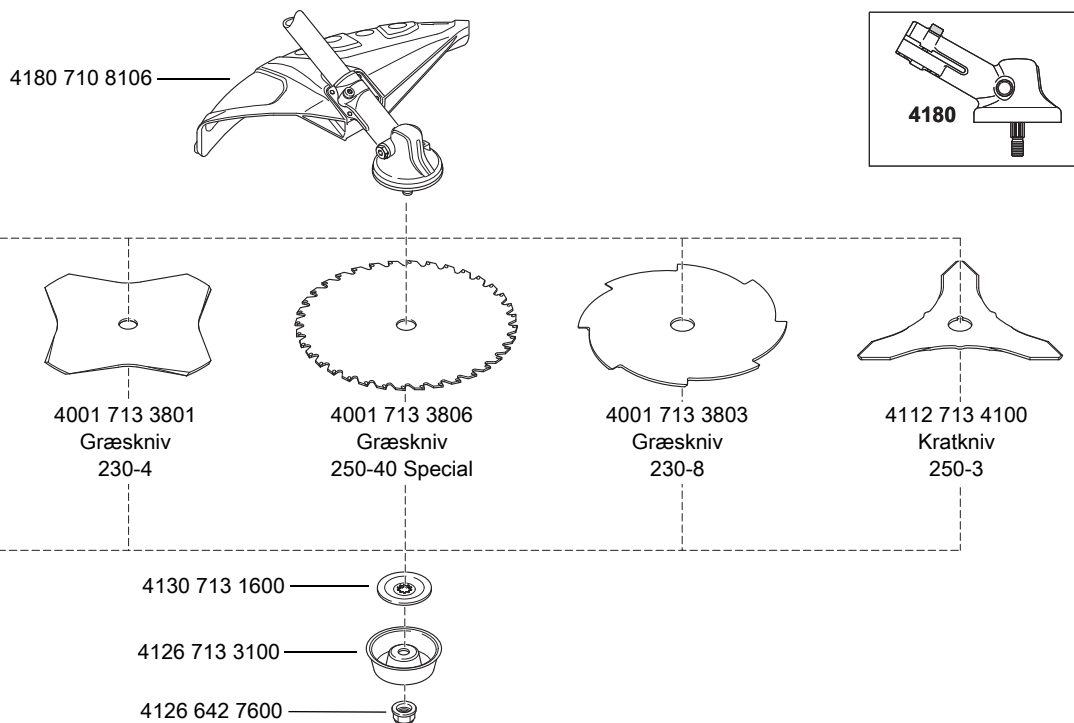

0000-GXX-3464-A0

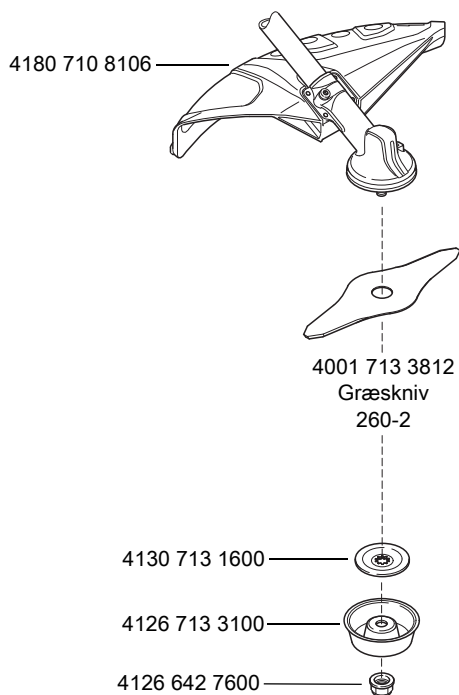

0000-GXX-5719-A0

(a) fra 2015

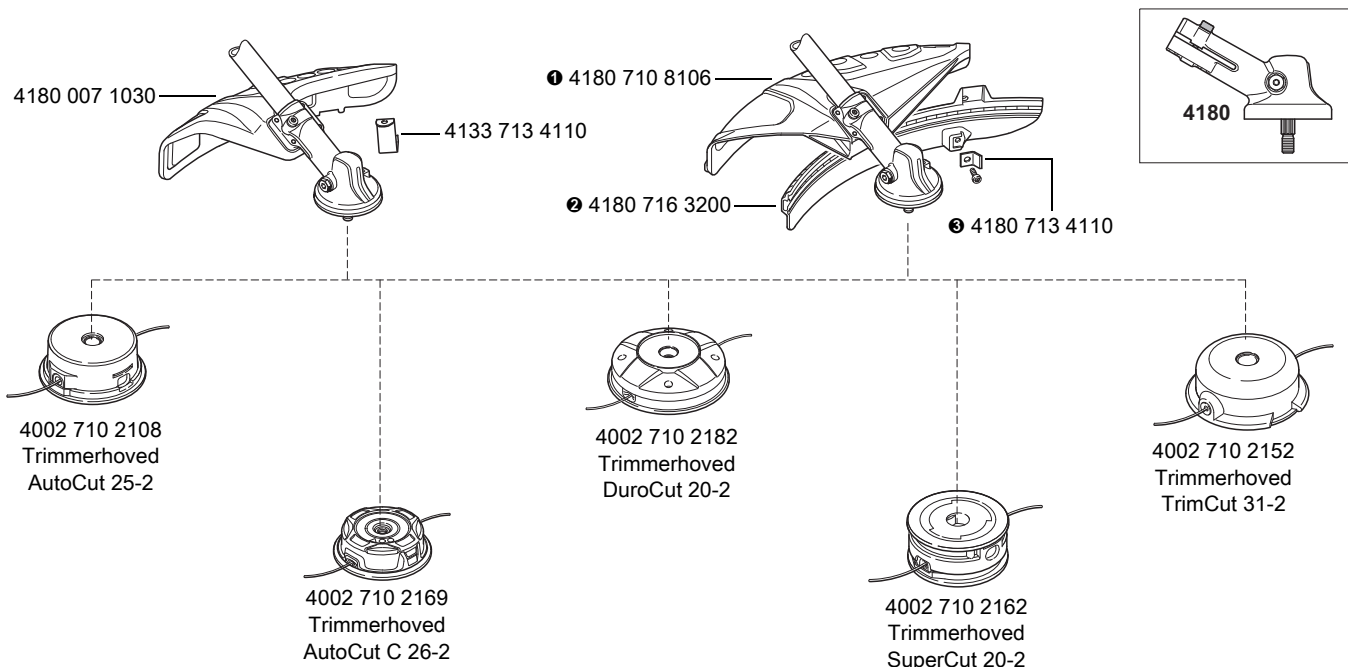

0000-GXX-8227-A0

❶ + ❷ + ❸ = 4180 007 1028

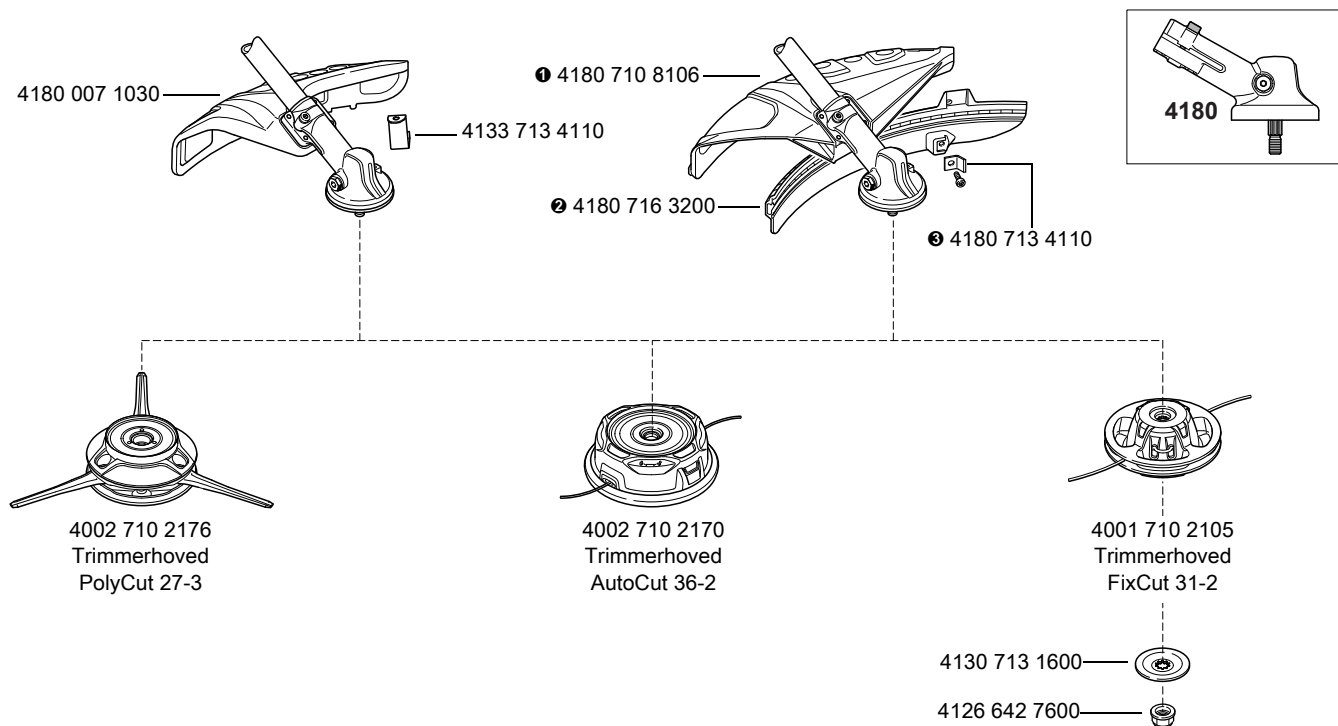

0000-GXX-9171-A0

❶ + ❷ + ❸ = 4180 007 1028

(a) fra 2015

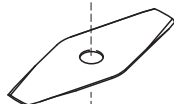
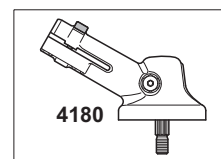
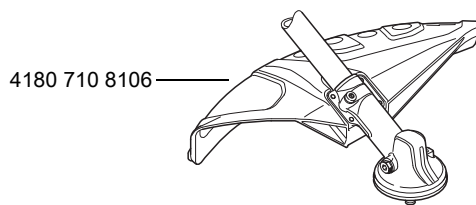

4001 713 3805
Græskniv
230-2



4001 713 3801
Græskniv
230-4



4001 713 3803
Græskniv
230-8

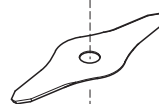

4001 713 3812
Græskniv
260-2



4112 713 4100
Kratkniv
250-3

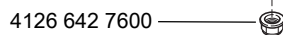
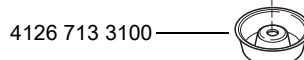
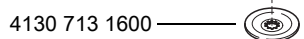

0000-GXX-6229-A0

FSE 31

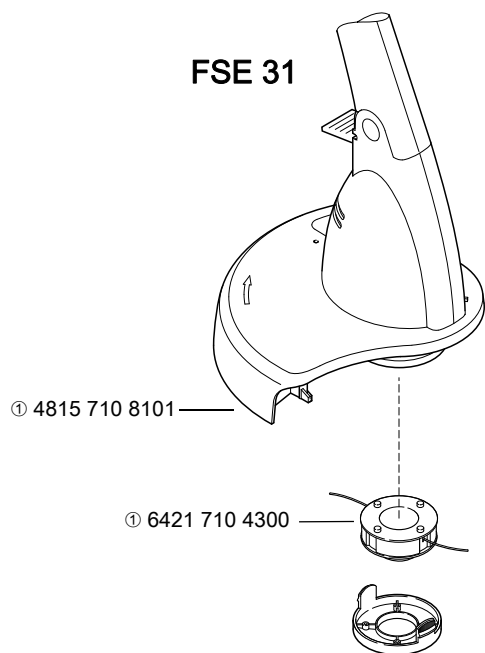

FSE 41

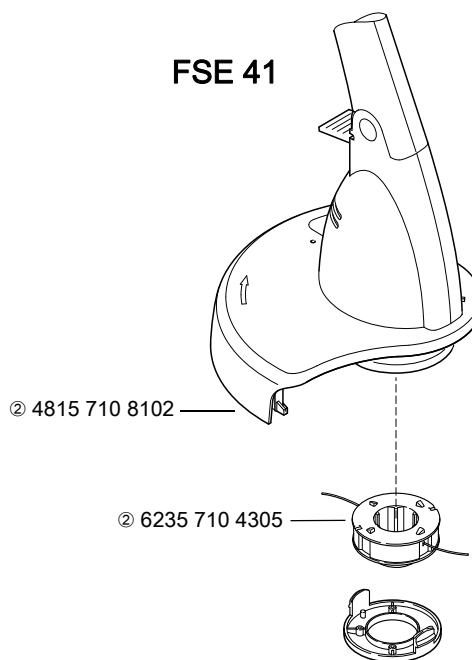

① FSE 31

② FSE 41

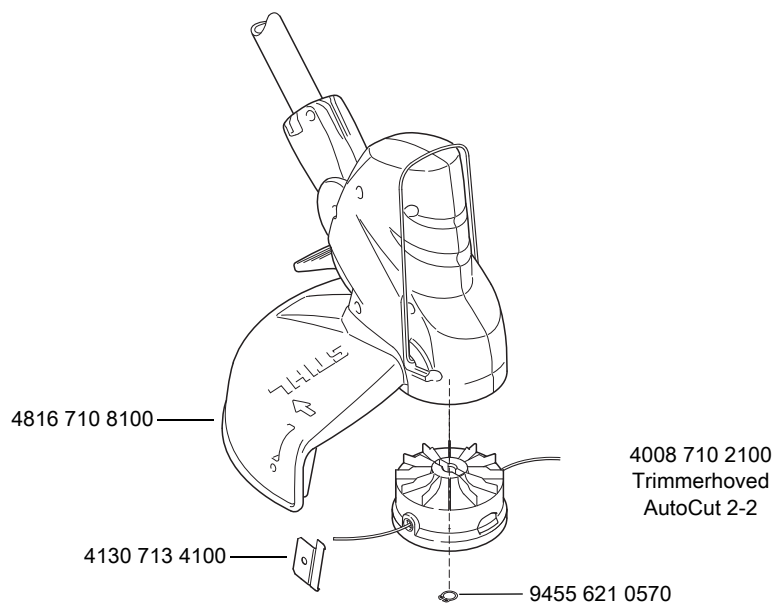

681KT796-A1

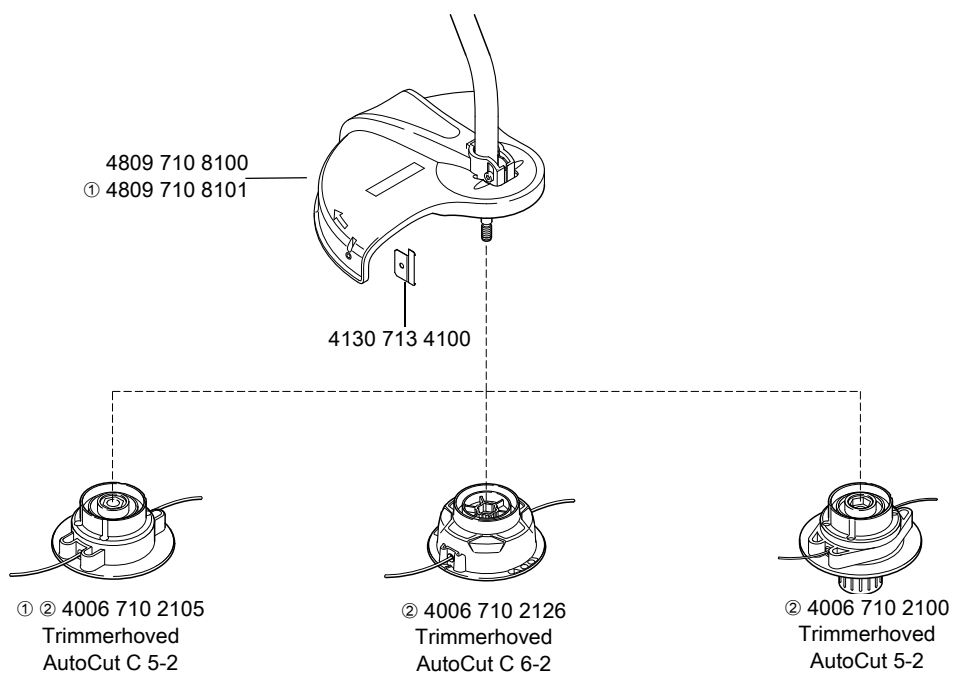

0000-GXX-3471-A0

① Leveres ikke længere

② Anvend støjsvag trimmertråd

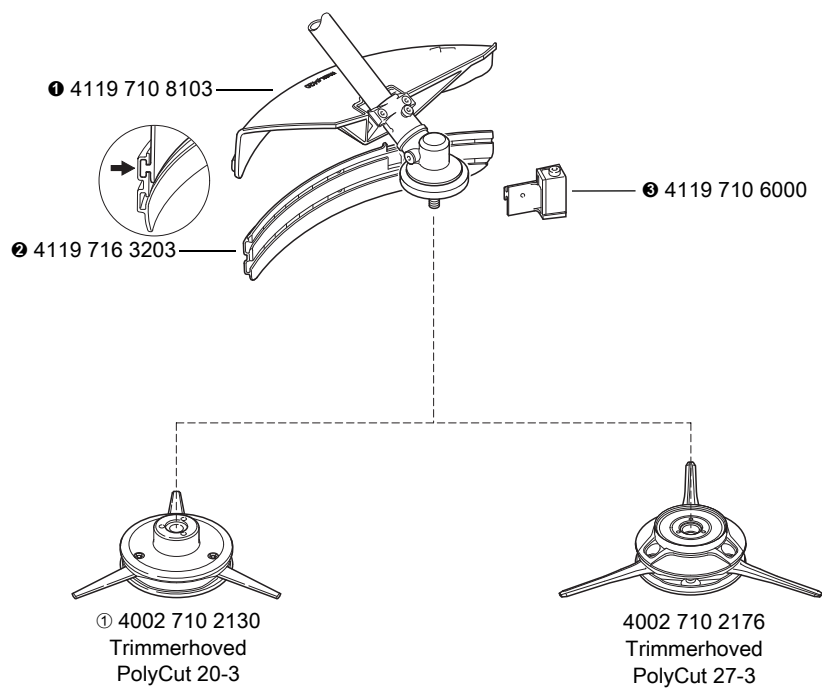

0000-GXX-5744-A0

① Leveres ikke længere

① + ② + ③ = 4119 007 1027

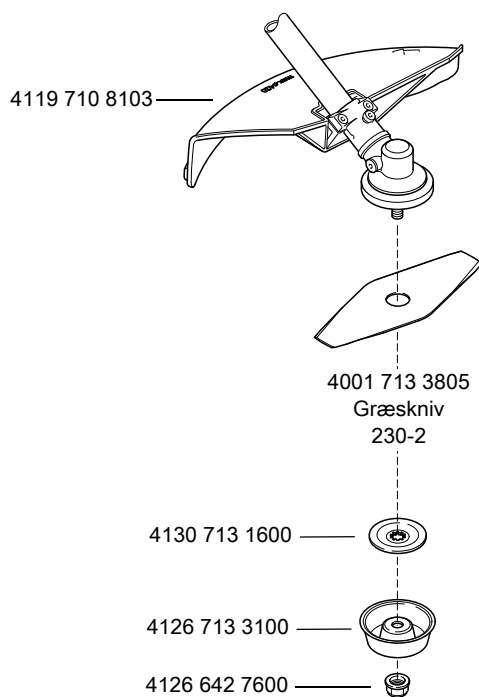

681KT585 KN

(a) fra 2017

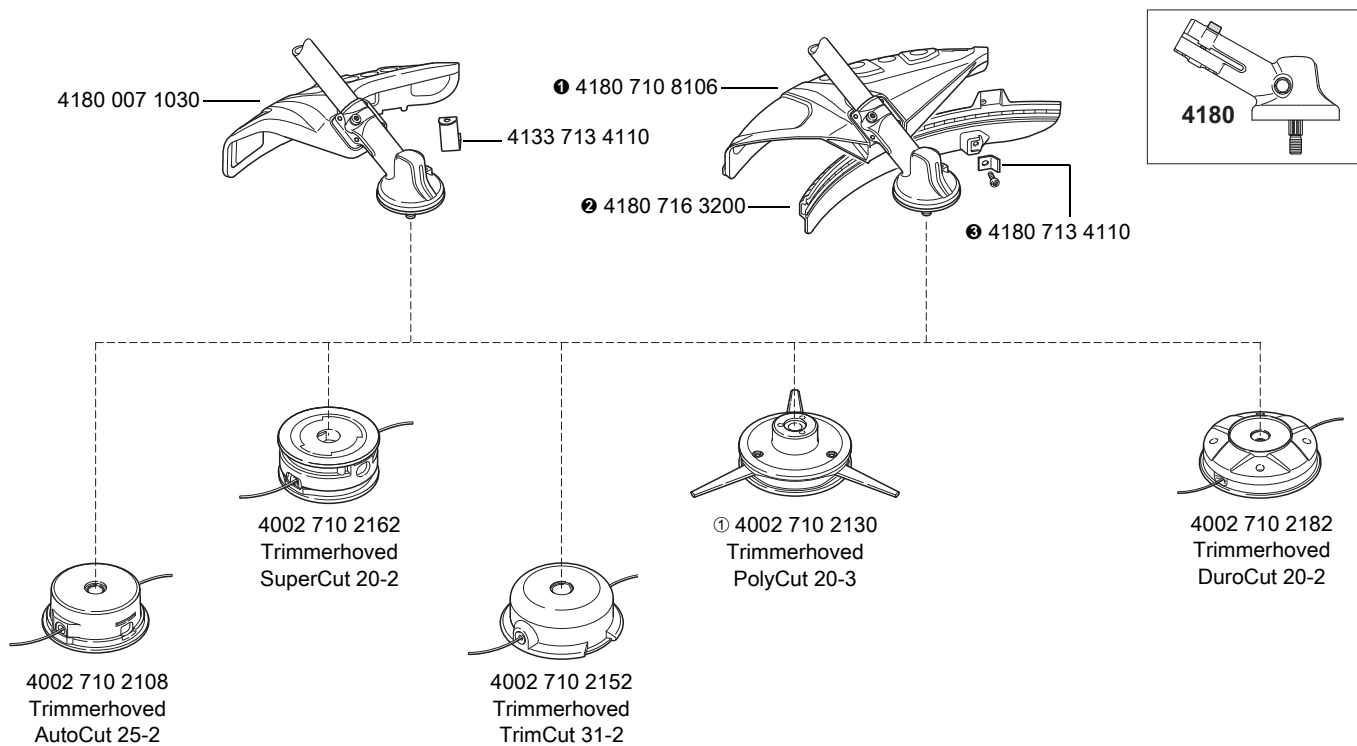

0000-GXX-5553-A0

① Leveres ikke længere

① + ② + ③ = 4180 007 1028

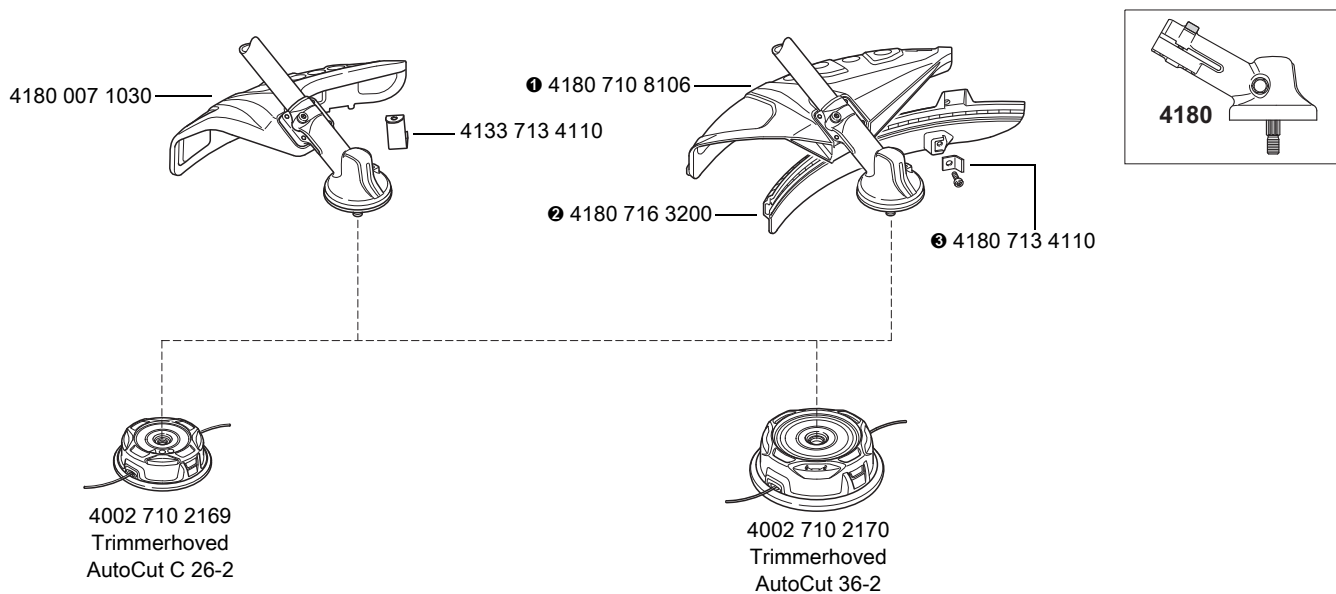

0000-GXX-5552-A0

① + ② + ③ = 4180 007 1028

(a) fra 2017

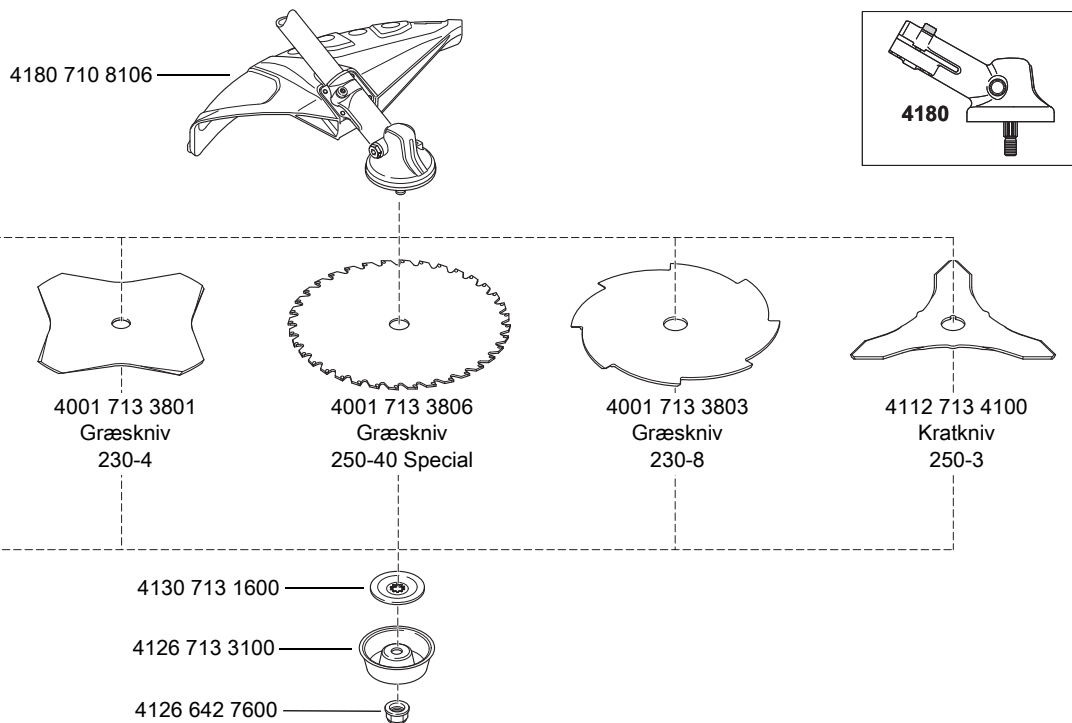

0000-GXX-5551-A0

❶ + ❷ + ❸ = 4180 007 1028

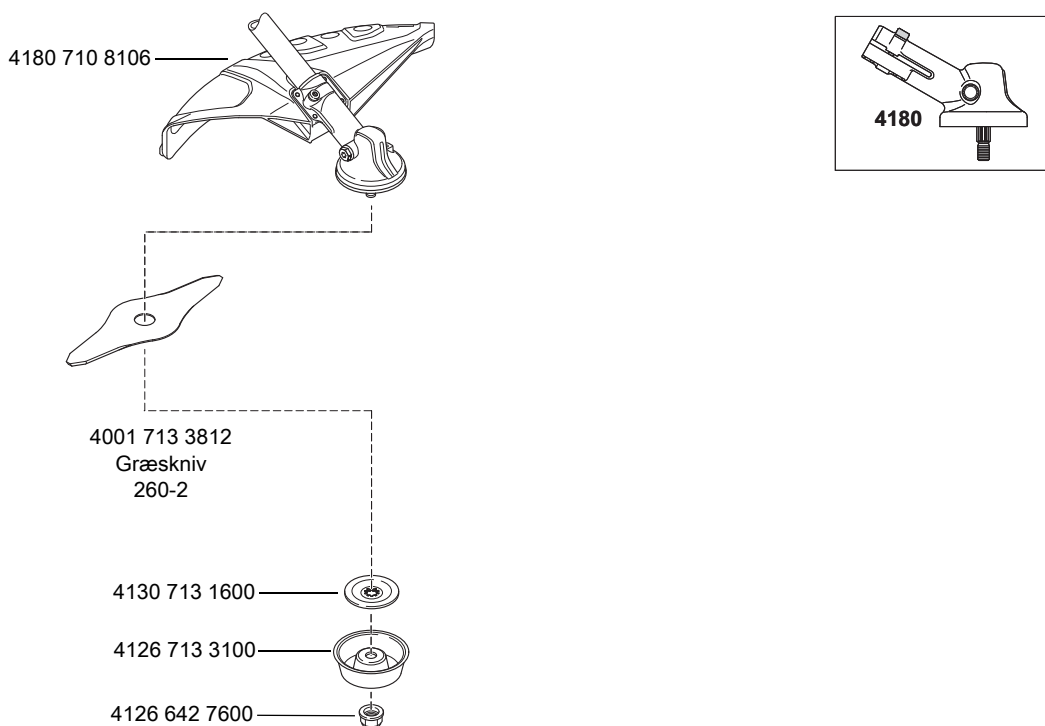

0000-GXX-5550-A0

(a) fra 2017

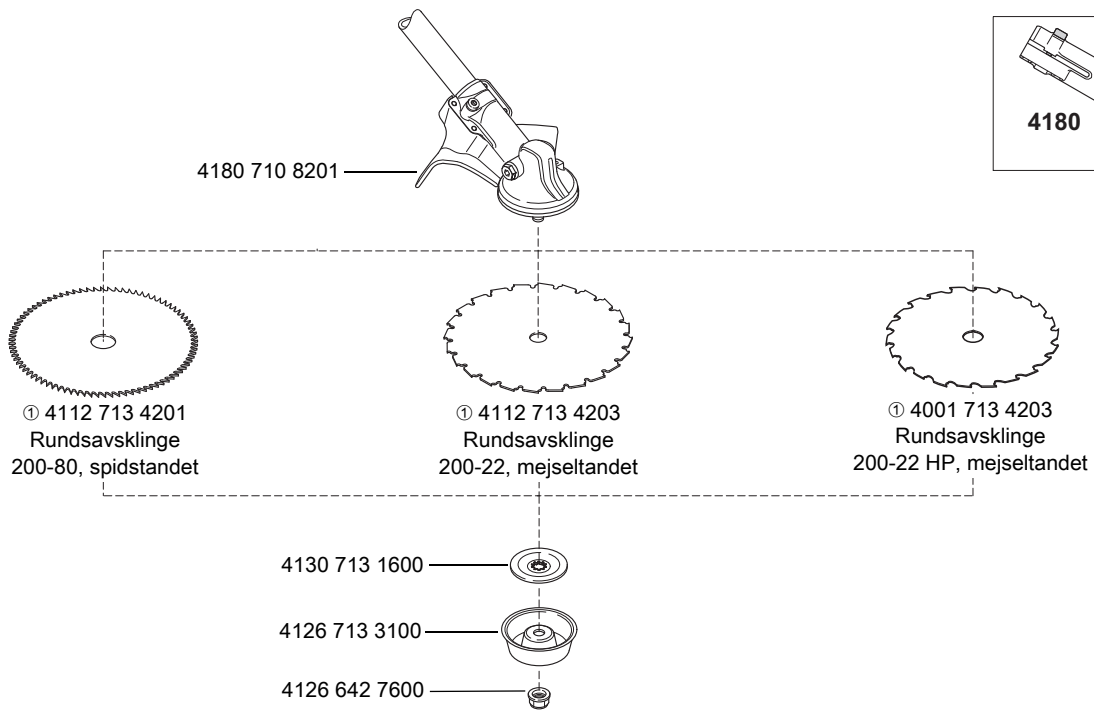

0000-GXX-5547-A0

① Ikke tilladt på trimmere med specialhåndtag

① Ikke tilladt på redskaber med specialhåndtag

(a) indtil 2017

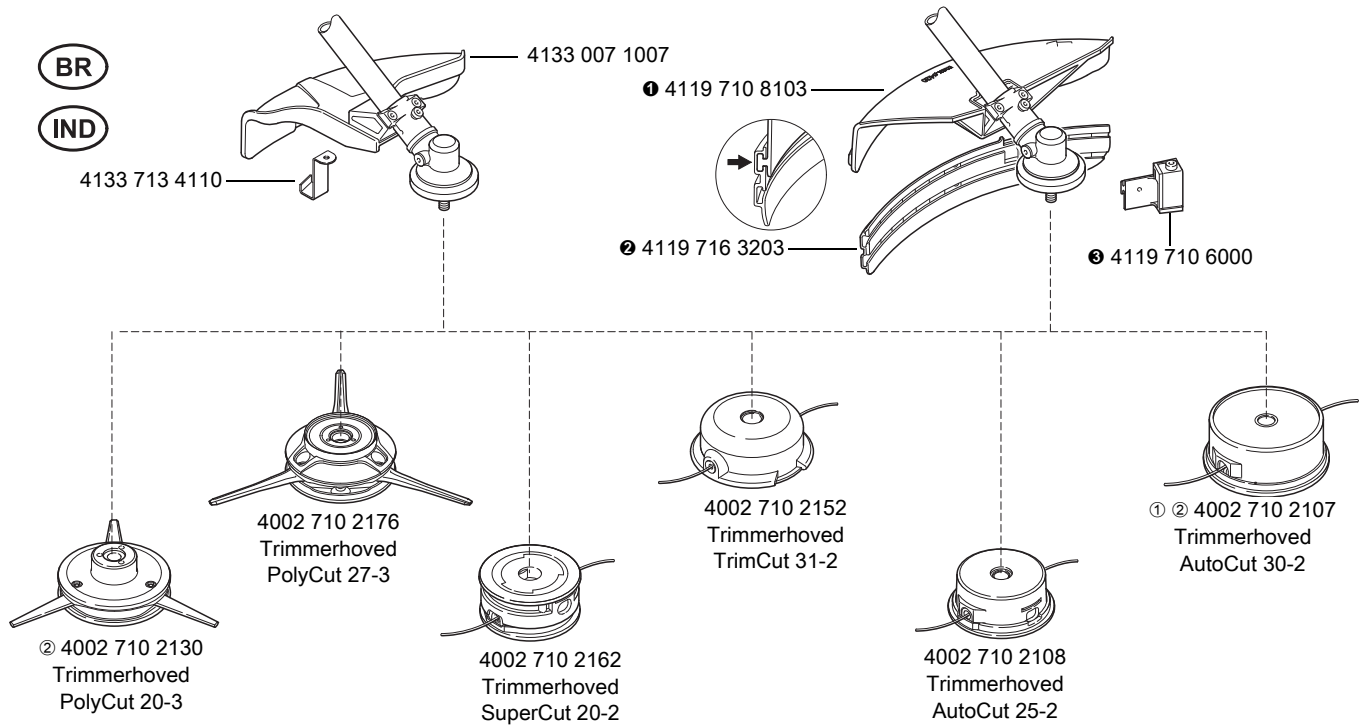

0000-GXX-5745-A0

② Ikke tilladt til KA 85, KR 85

② Leveres ikke længere

① + ② + ③ = 4119 007 1027

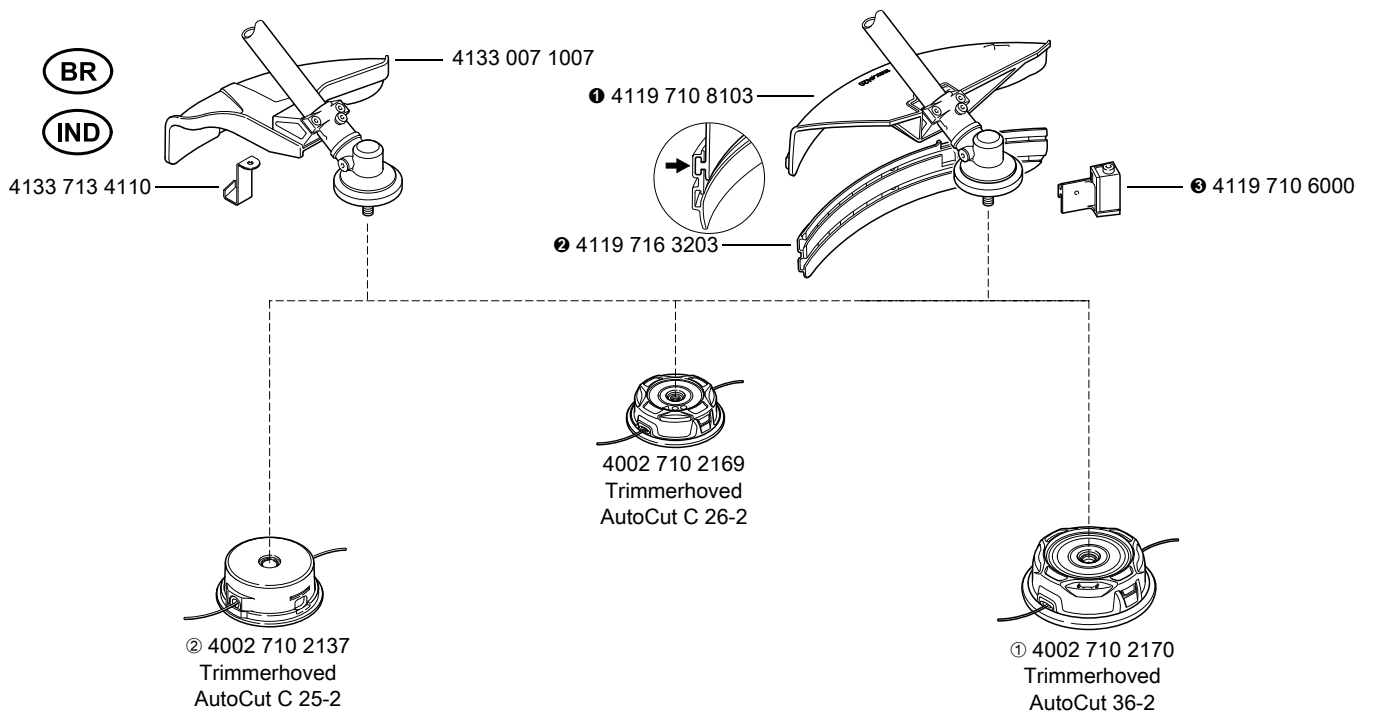

0000-GXX-3472-A0

② Ikke tilladt til KA 85, KR 85

② Leveres ikke længere

① + ② + ③ = 4119 007 1027

(a) indtil 2017

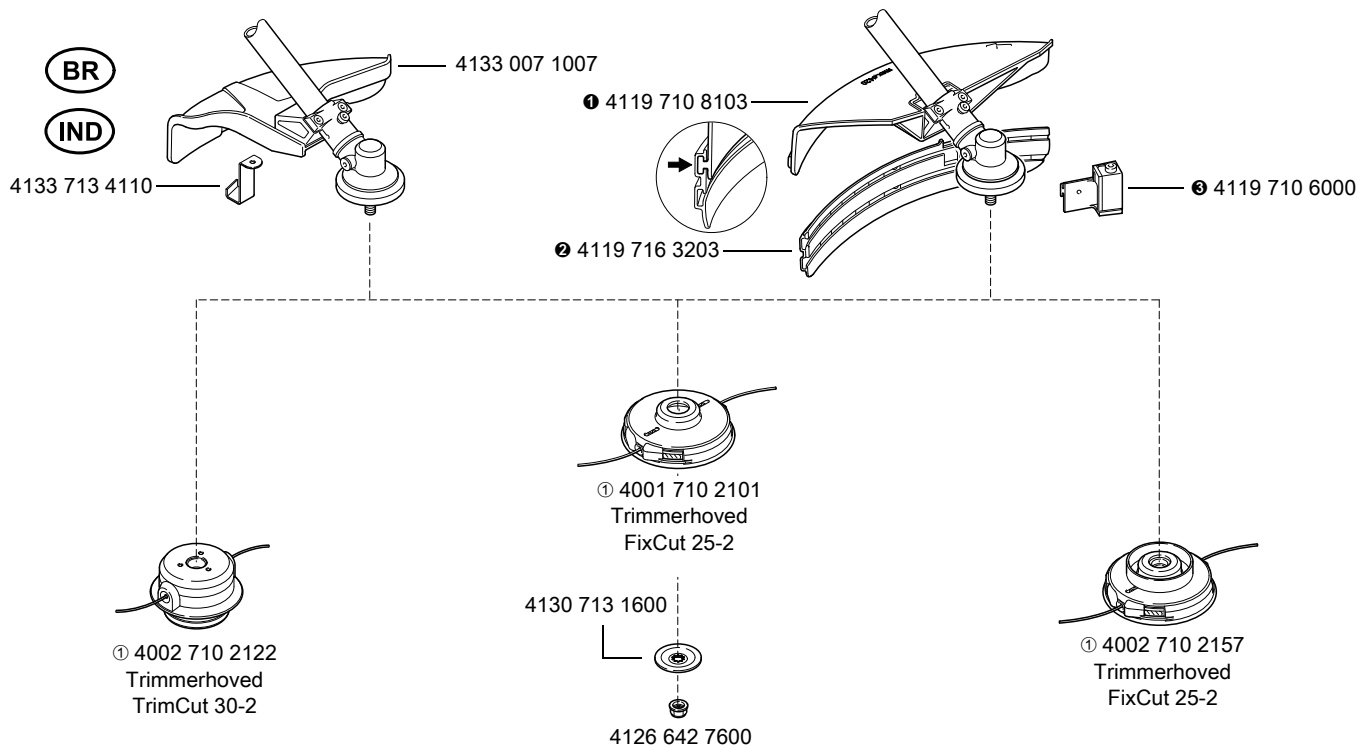

0 000-GXX-3473-A0

① Leveres ikke længere

① + ② + ③ = 4119 007 1027

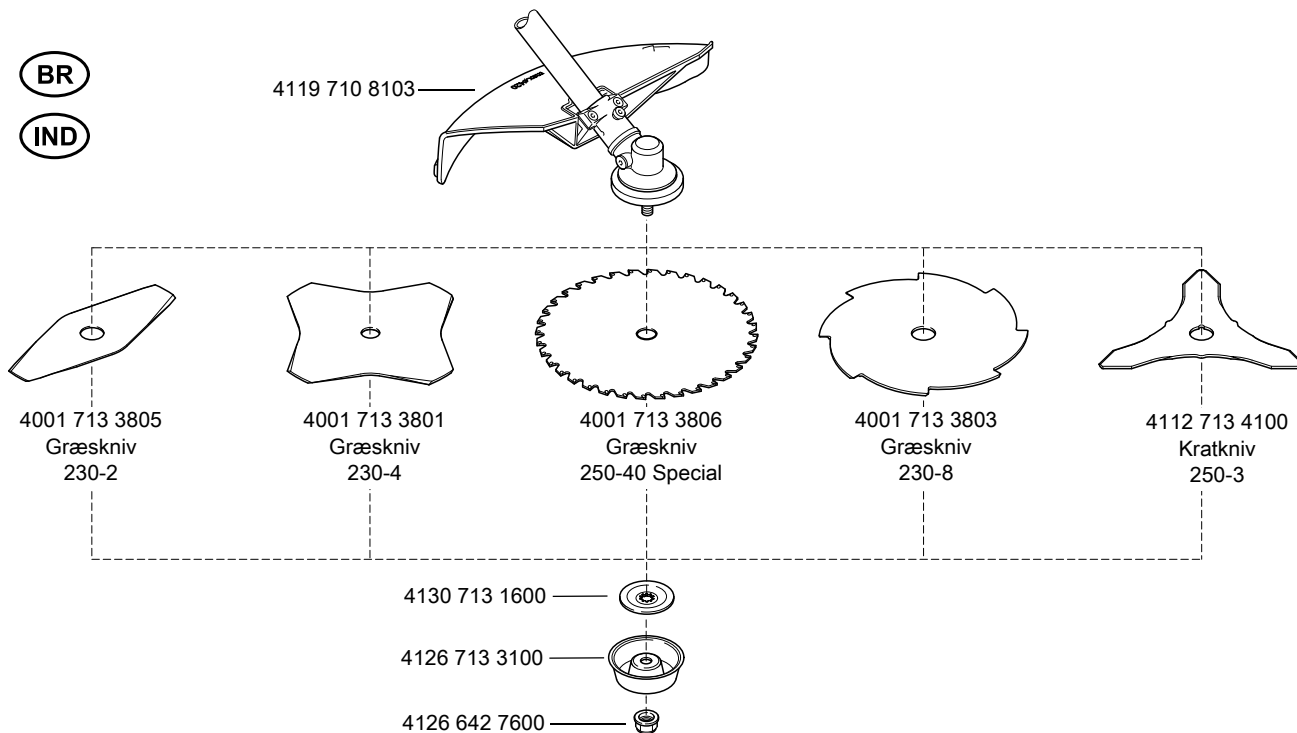

381KT1001 KN

(a) indtil 2017

BR

IND

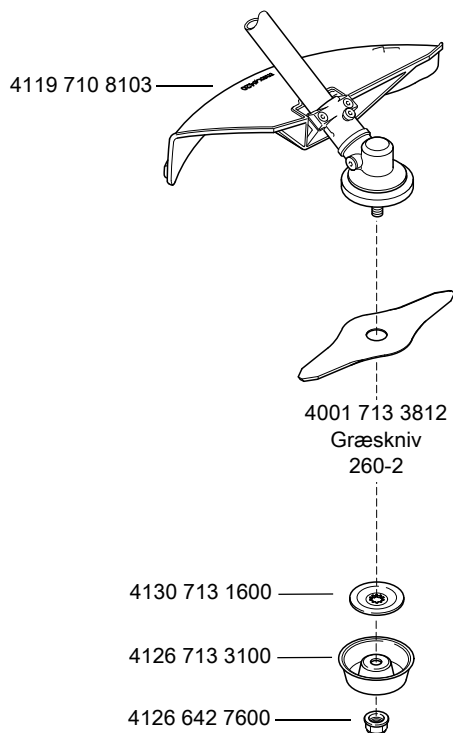

681KT1090-KN

BR

IND

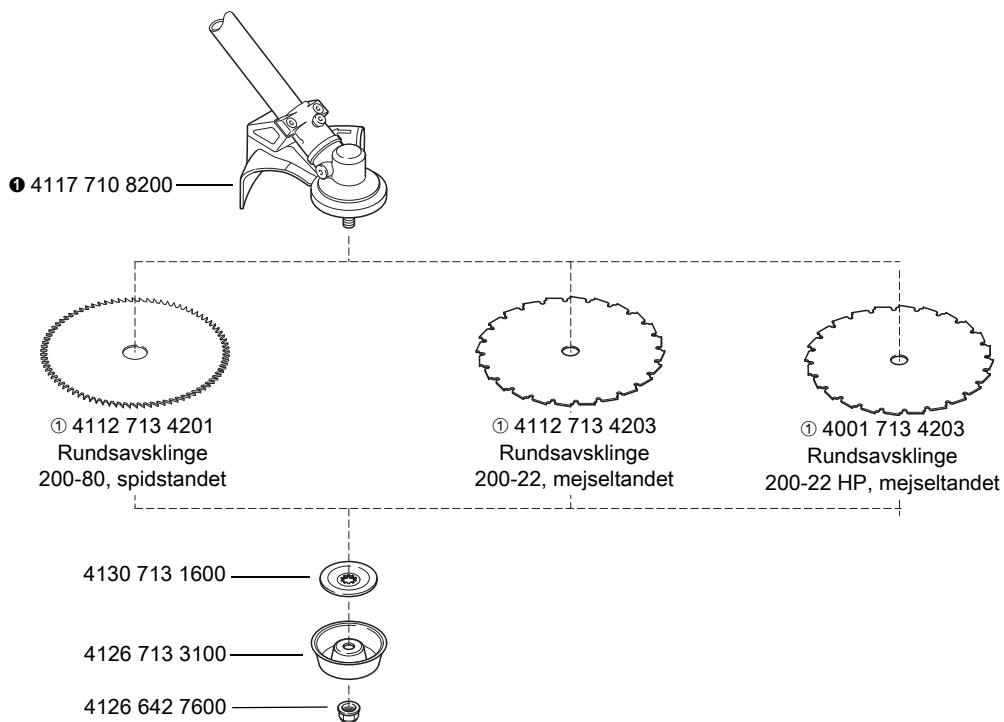

381KT1002-A1

❶ Ikke tilladt på redskaber med specialhåndtag

❶ + transportbeskyttelse = 4126 007 1002

(a) fra 2015

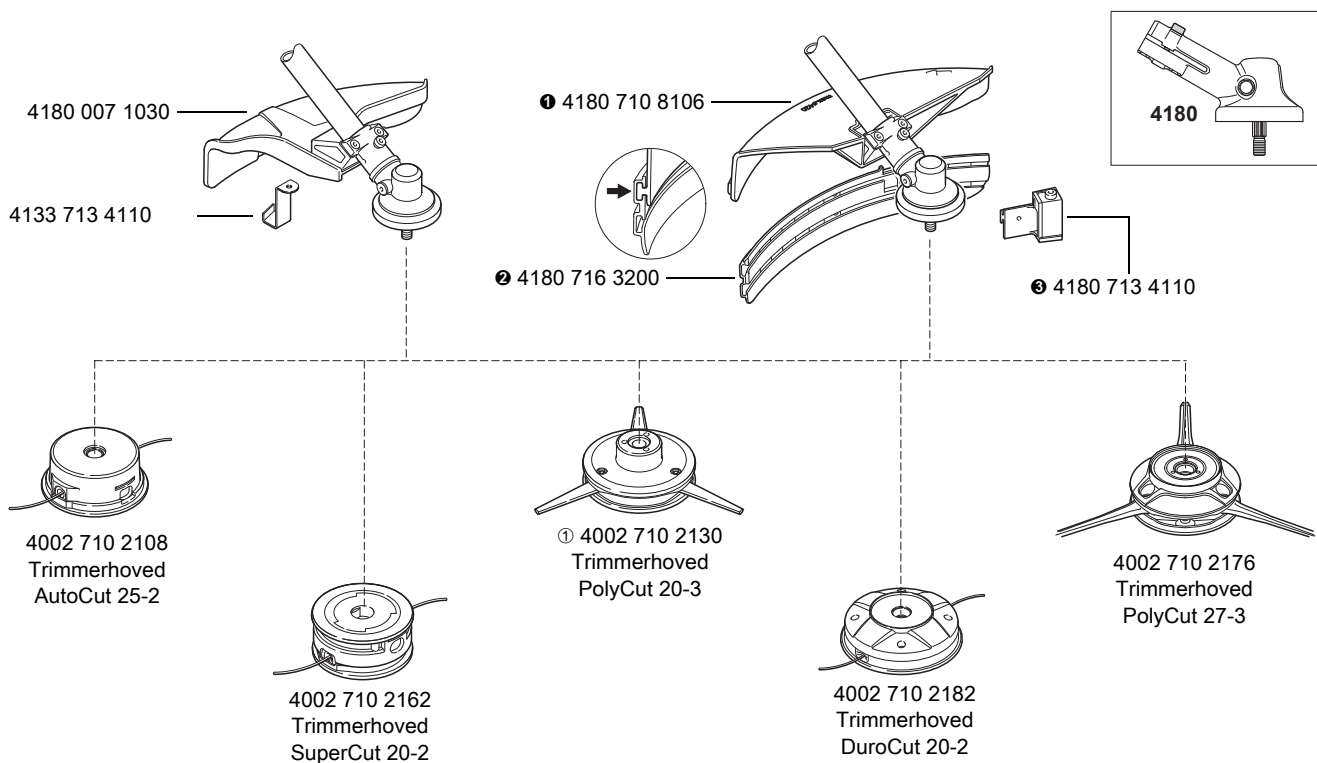

0000-GXX-5747-A0

① Leveres ikke længere

① + ② + ③ = 4180 007 1028

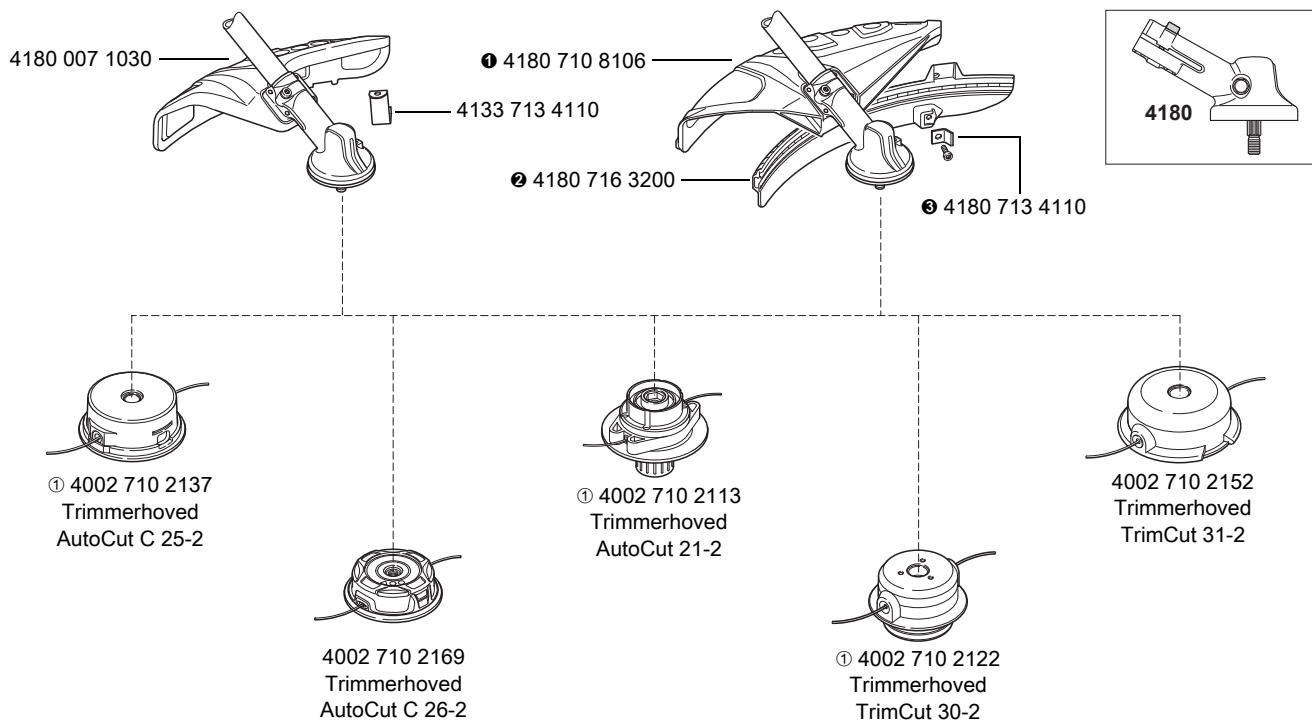

0000-GXX-3474-A1

① Leveres ikke længere

① + ② + ③ = 4180 007 1028

(a) fra 2015

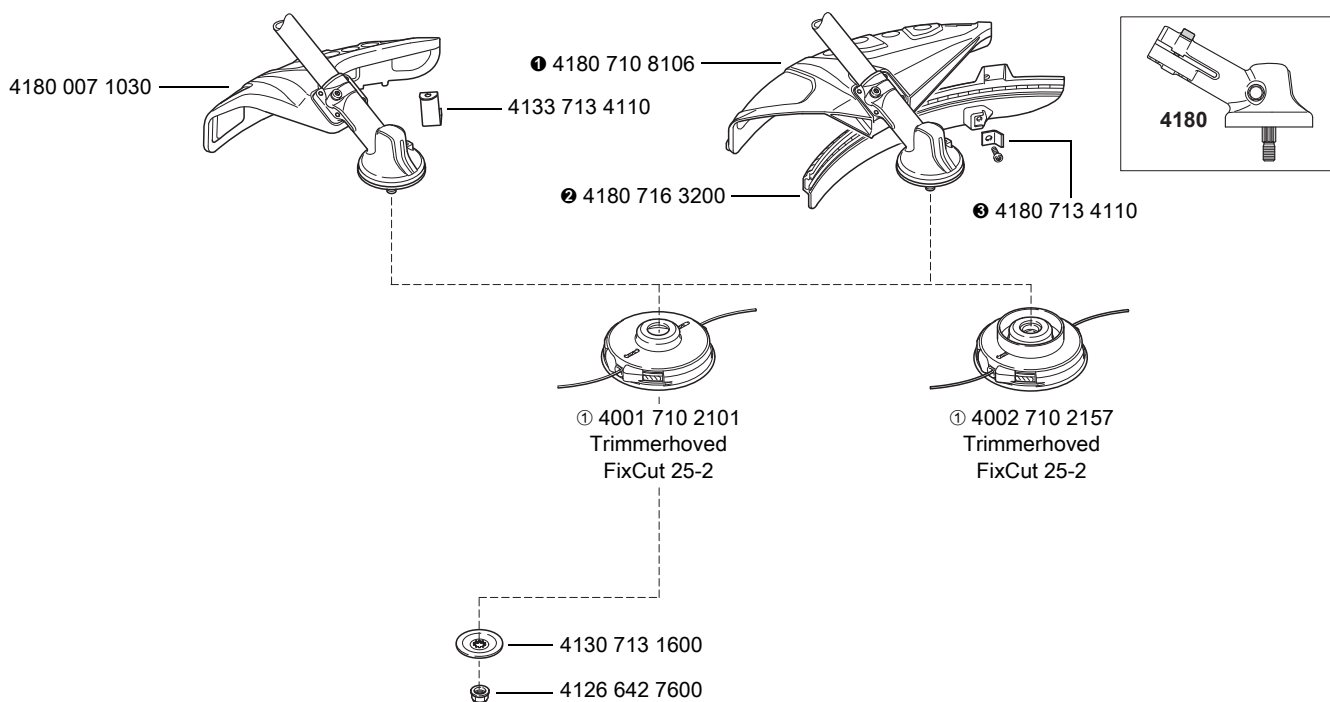

681KT992-A1

① Leveres ikke længere

① + ② + ③ = 4180 007 1028

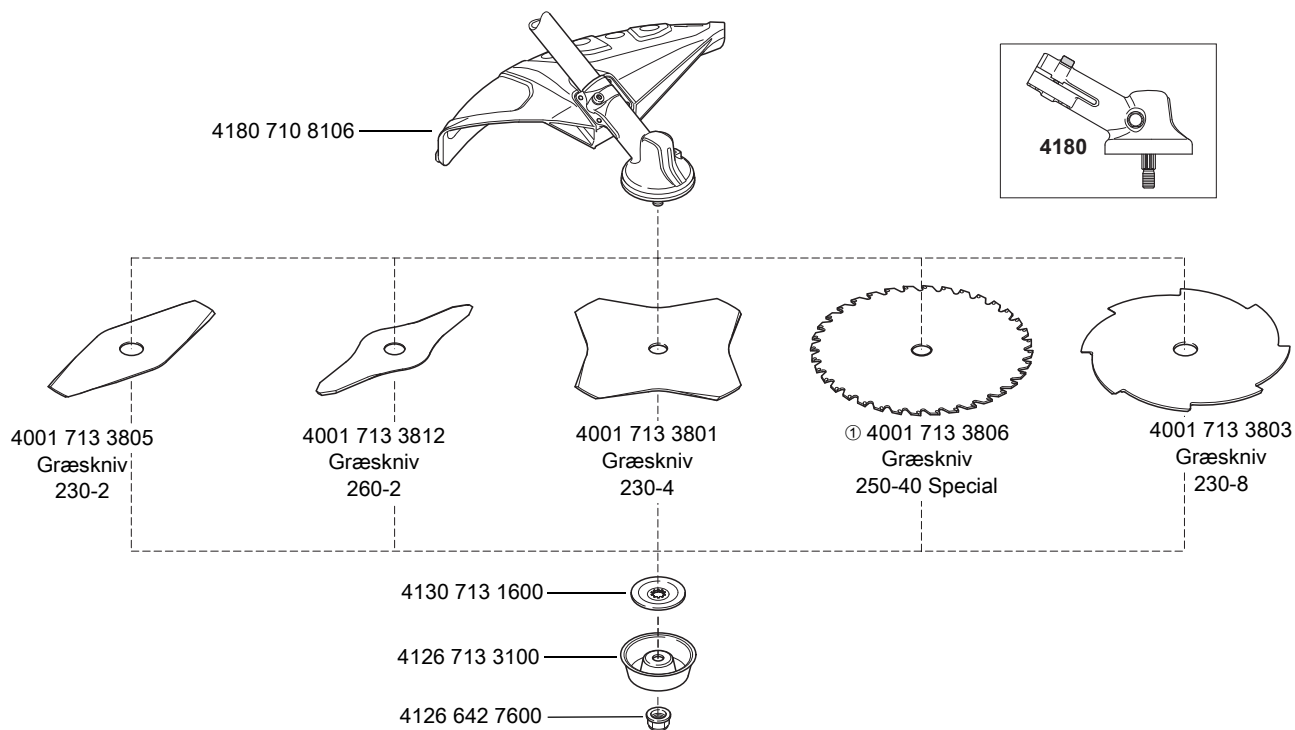

① Ikke tilladt til KM 56

381KT1091 KN

(a) indtil 2015

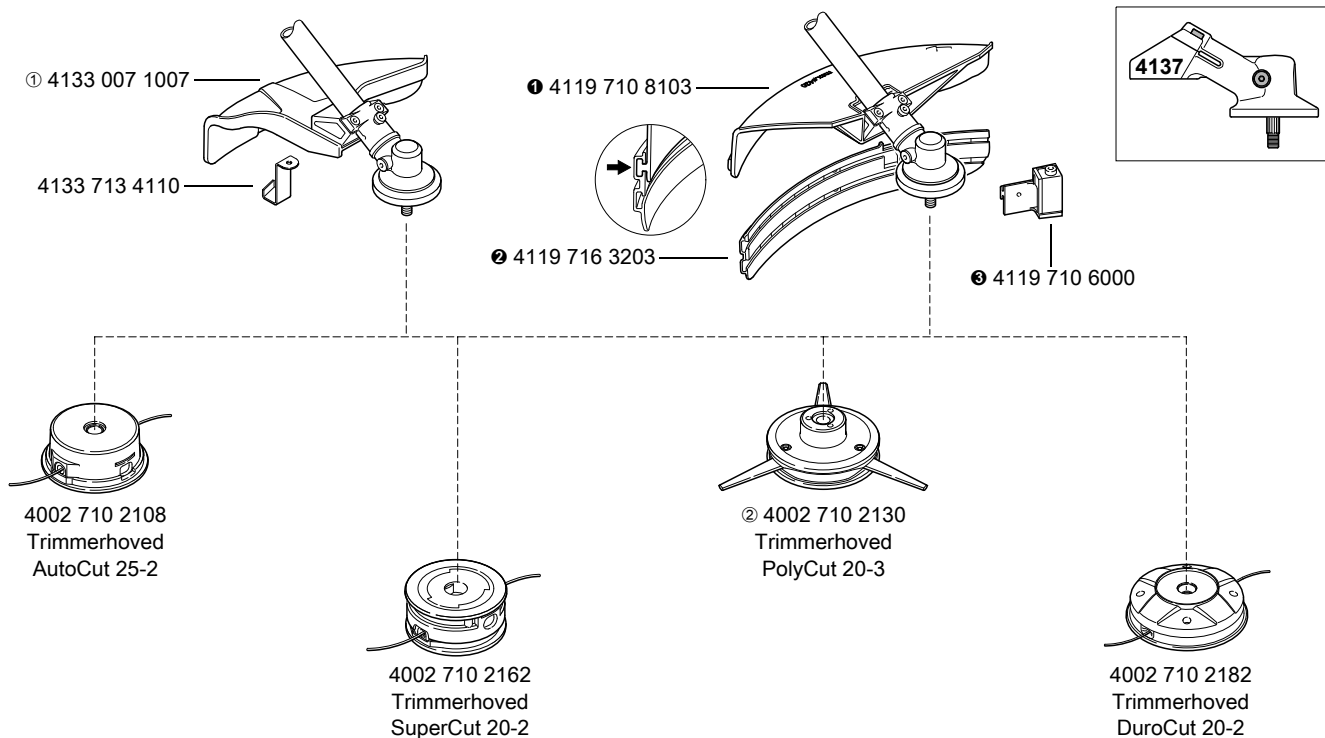

681KT805 KN

① Kun tilladt i AUS, NZL: 4133 007 1008

② Leveres ikke længere

① + ② + ③ = 4119 007 1027

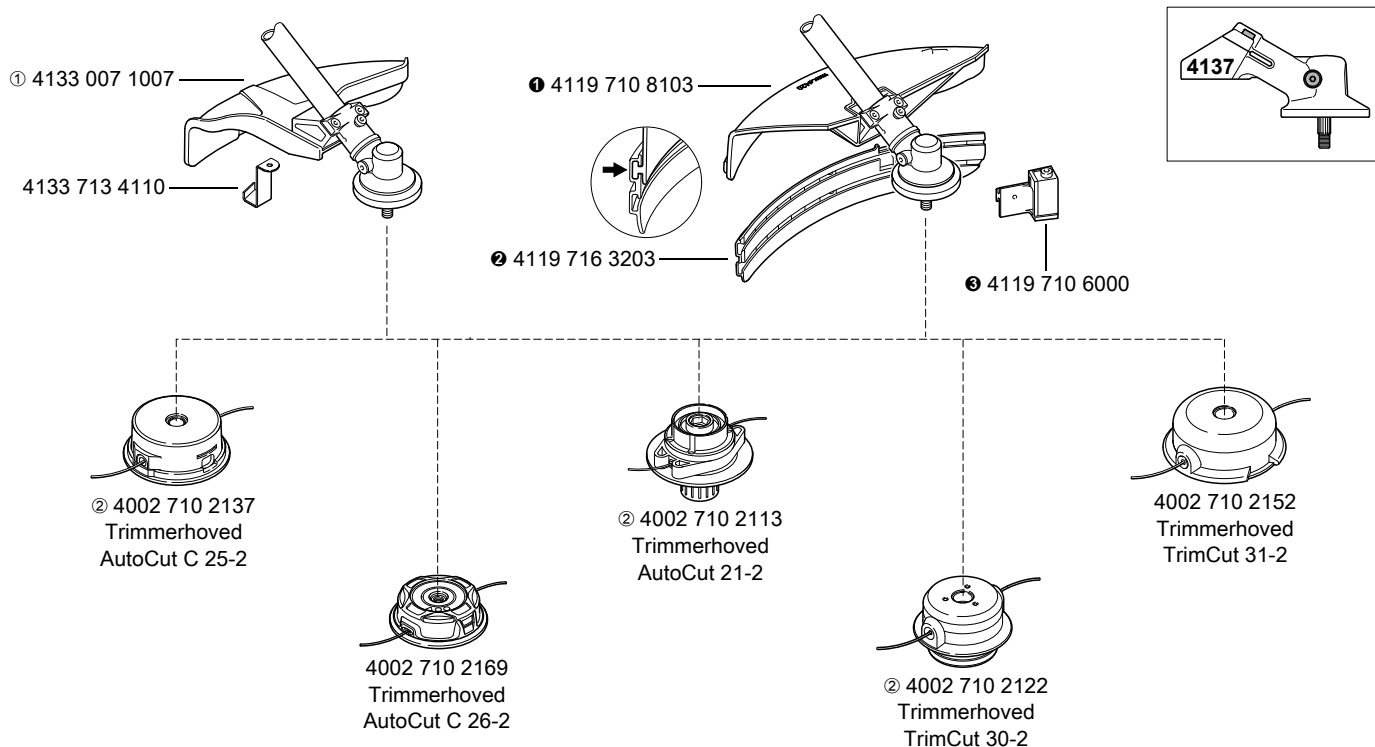

0000-GXX-3475-A0

① Kun tilladt i AUS, NZ: 4133 007 1008

② Leveres ikke længere

① + ② + ③ = 4119 007 1027

(a) indtil 2015

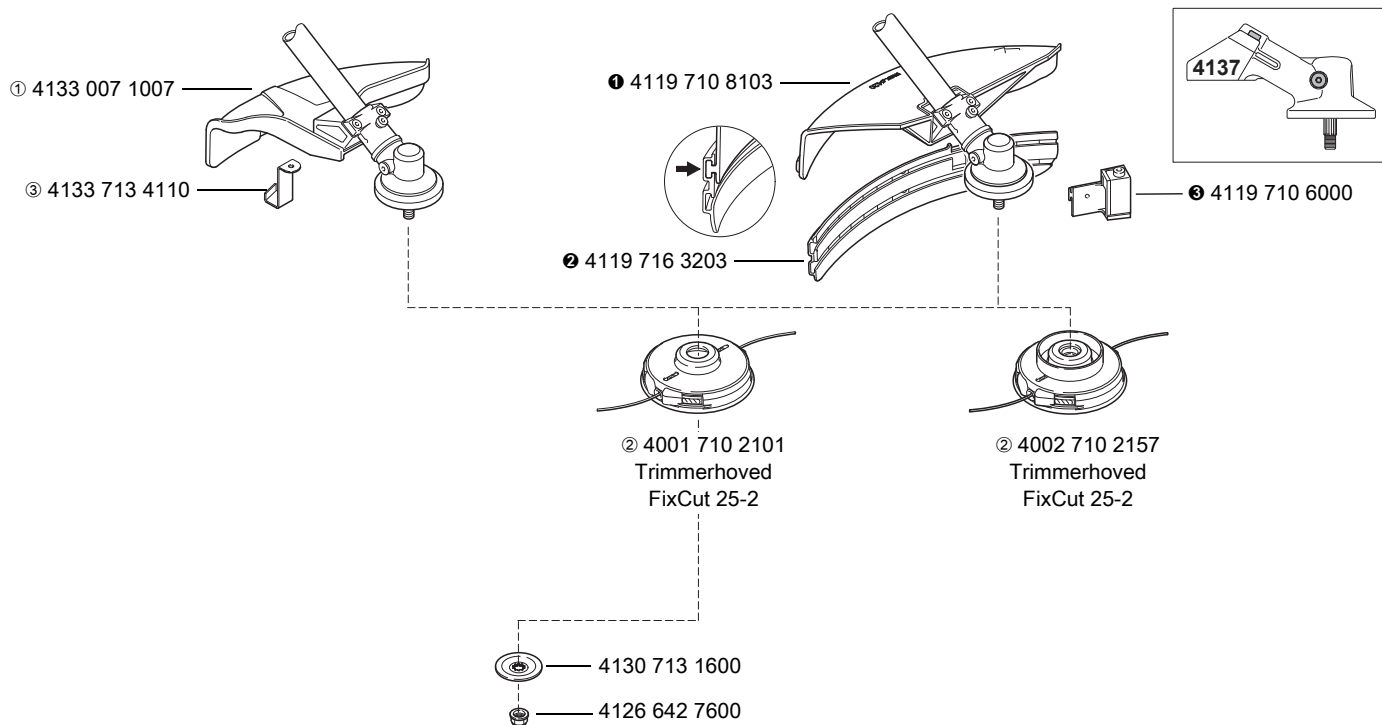

681KT913-A1

① Kun tilladt i AUS, NZ: 4133 007 1008

② Leveres ikke længere

❶ + ❷ + ❸ = 4119 007 1027

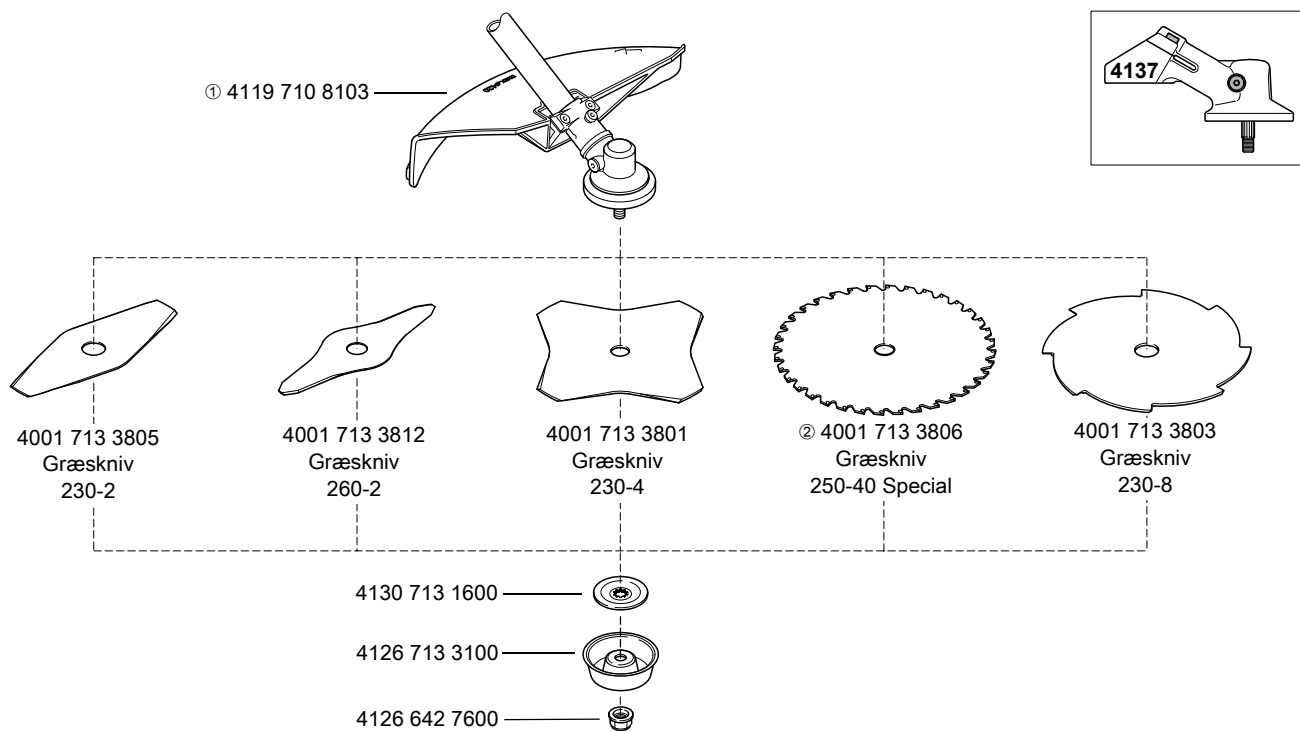

681KT1092-KN

① Beskyttelse til AUS, NZ, se billedet med "AUS, NZ"

② Ikke tilladt til KM 56

(a) indtil 2015

AUS NZ

4133 007 1008

4133 713 4110

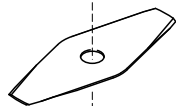
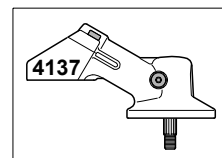
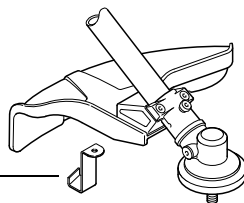

4001 713 3805
Græskniv
230-2

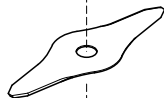

4001 713 3812
Græskniv
260-2

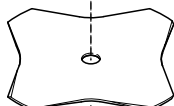

4001 713 3801
Græskniv
230-4

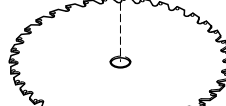

4001 713 3806
Græskniv
250-40 Special

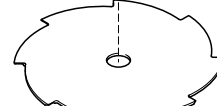

4001 713 3803
Græskniv
230-8

4130 713 1600



4126 713 3100



4126 642 7600



661KT1093 KN

(a) fra 2018

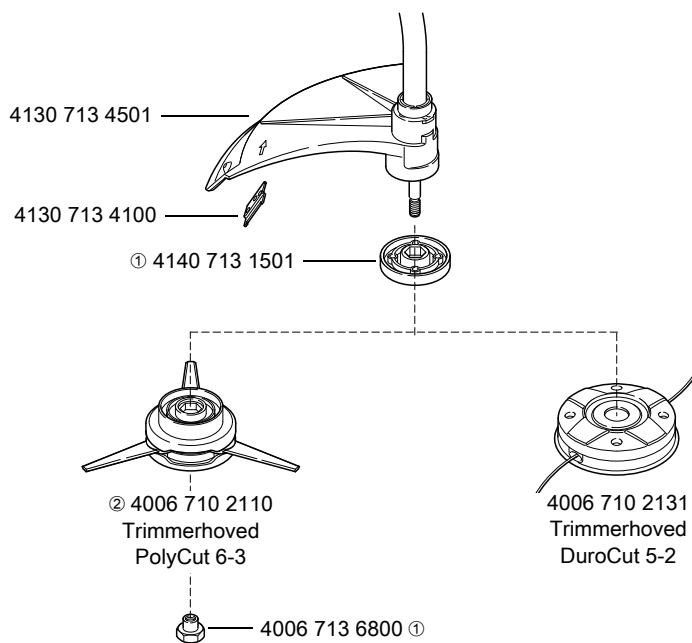

0000-GXX-8902-A0

① Delen leveres ikke sammen med trimmerhovedet

② Leveres ikke længere

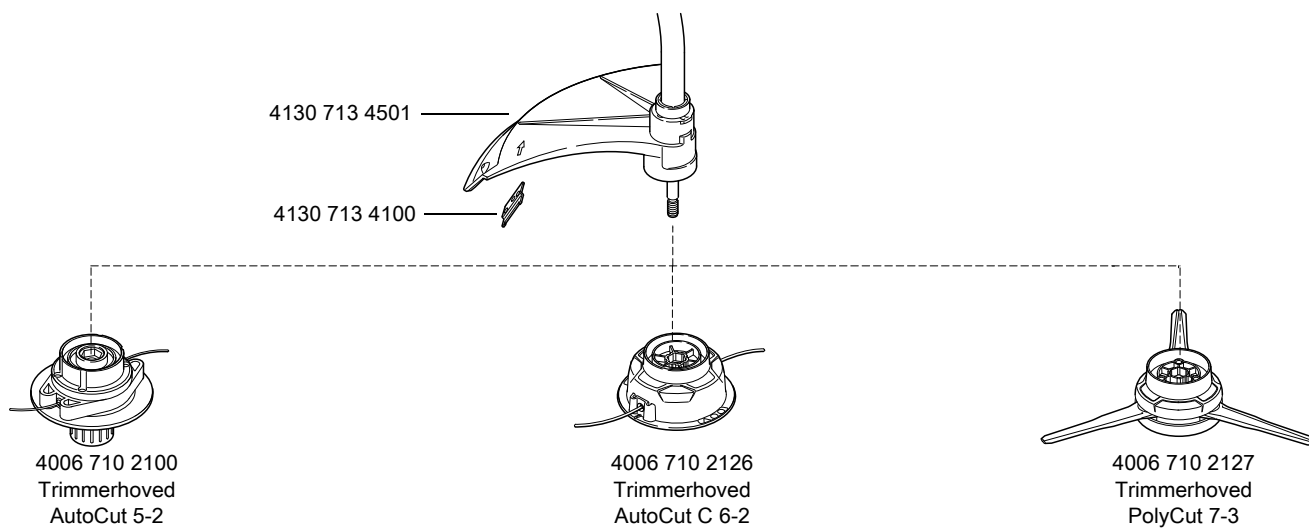

0000-GXX-8903-A0

(a) indtil 2017

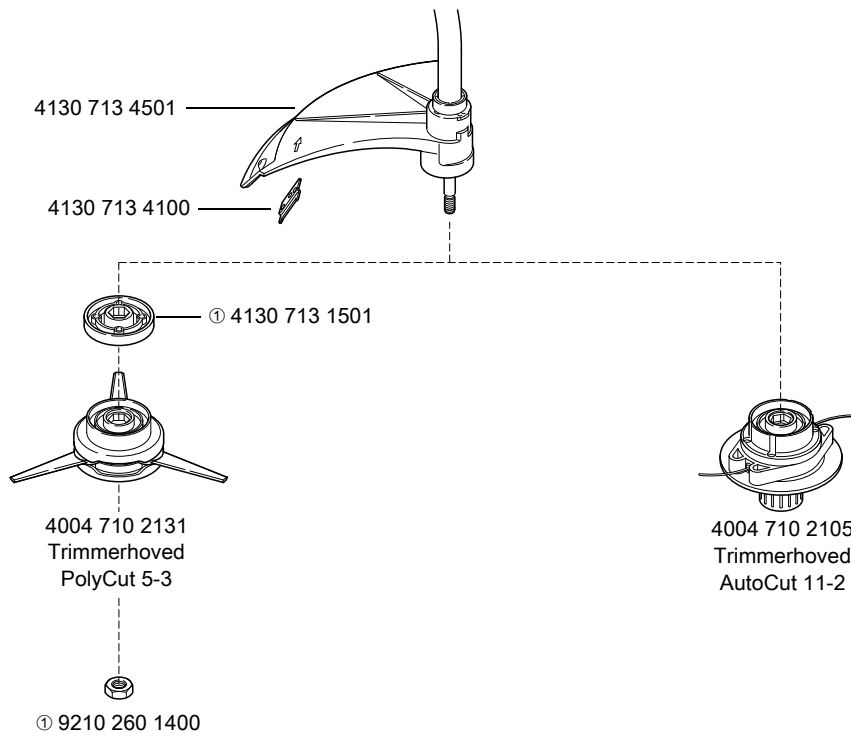

681KT923 KN

① Denne del leveres sammen med trimmerhovedet

(a) fra 2015

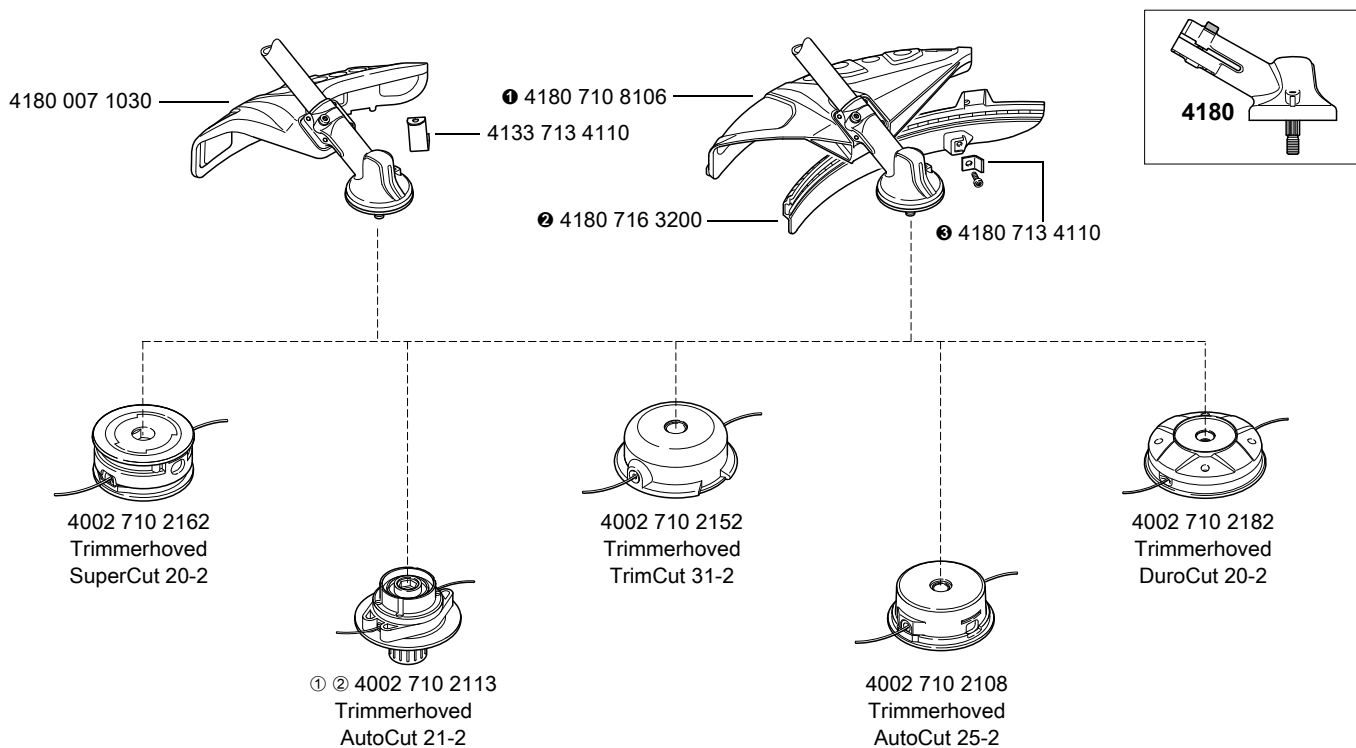

681KT994 KN

① Ikke tilladt til KM 130, 131

② Leveres ikke længere

① + ② + ③ = 4180 007 1028

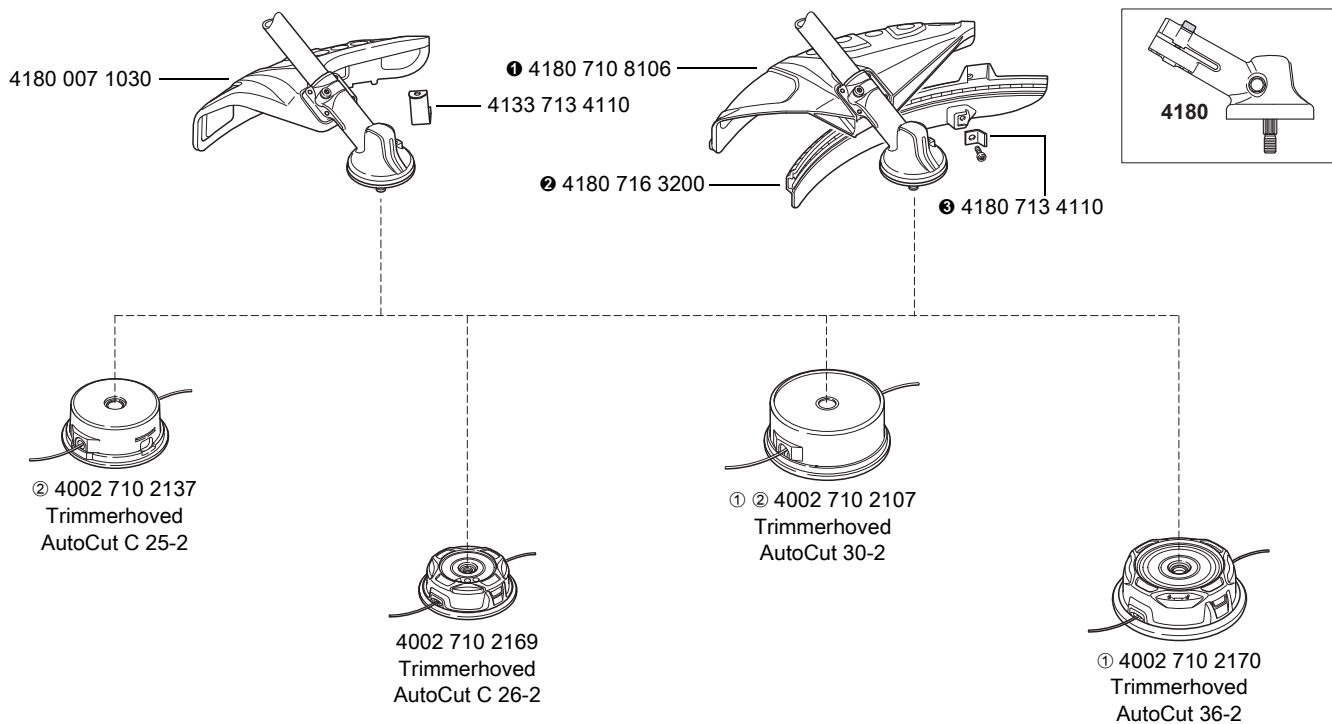

0000-GXX-3476-A1

① Ikke tilladt til KM 130, 131

② Leveres ikke længere

① + ② + ③ = 4180 007 1028

(a) fra 2015

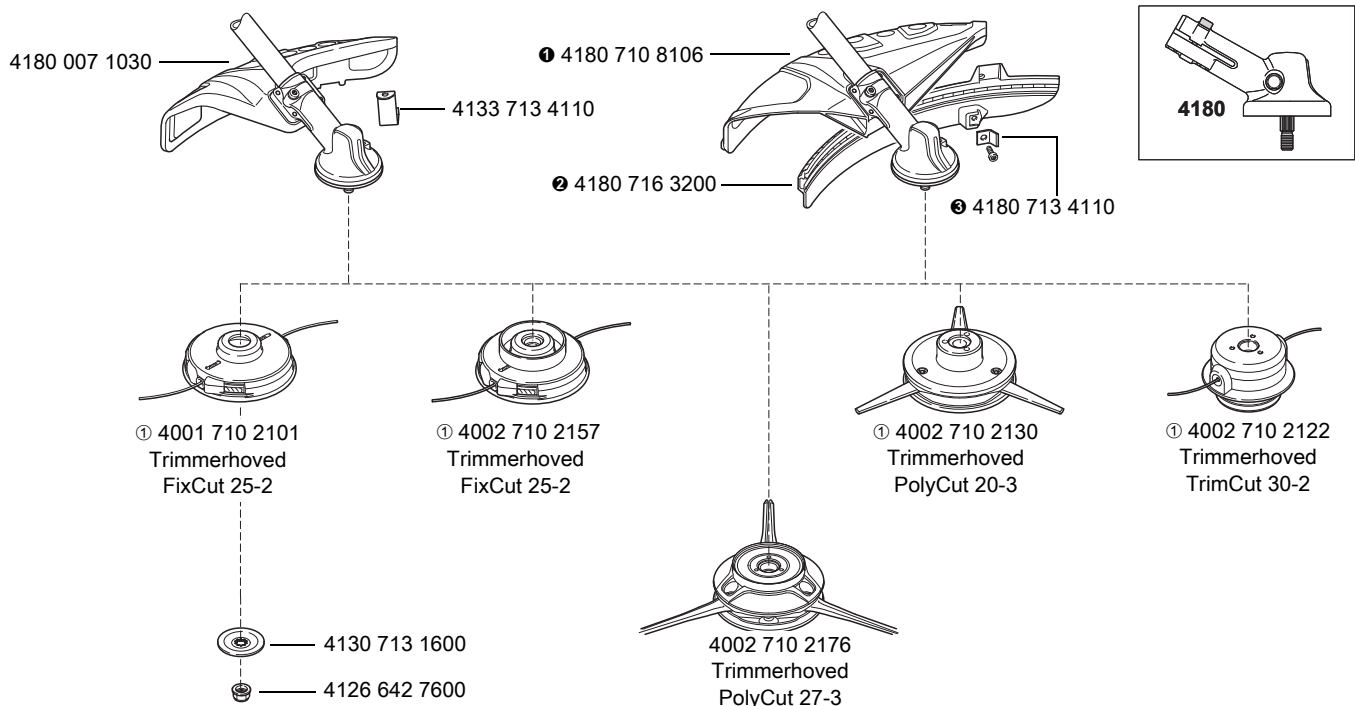

0000-GXX-5748-A0

① Leveres ikke længere

① + ② + ③ = 4180 007 1028

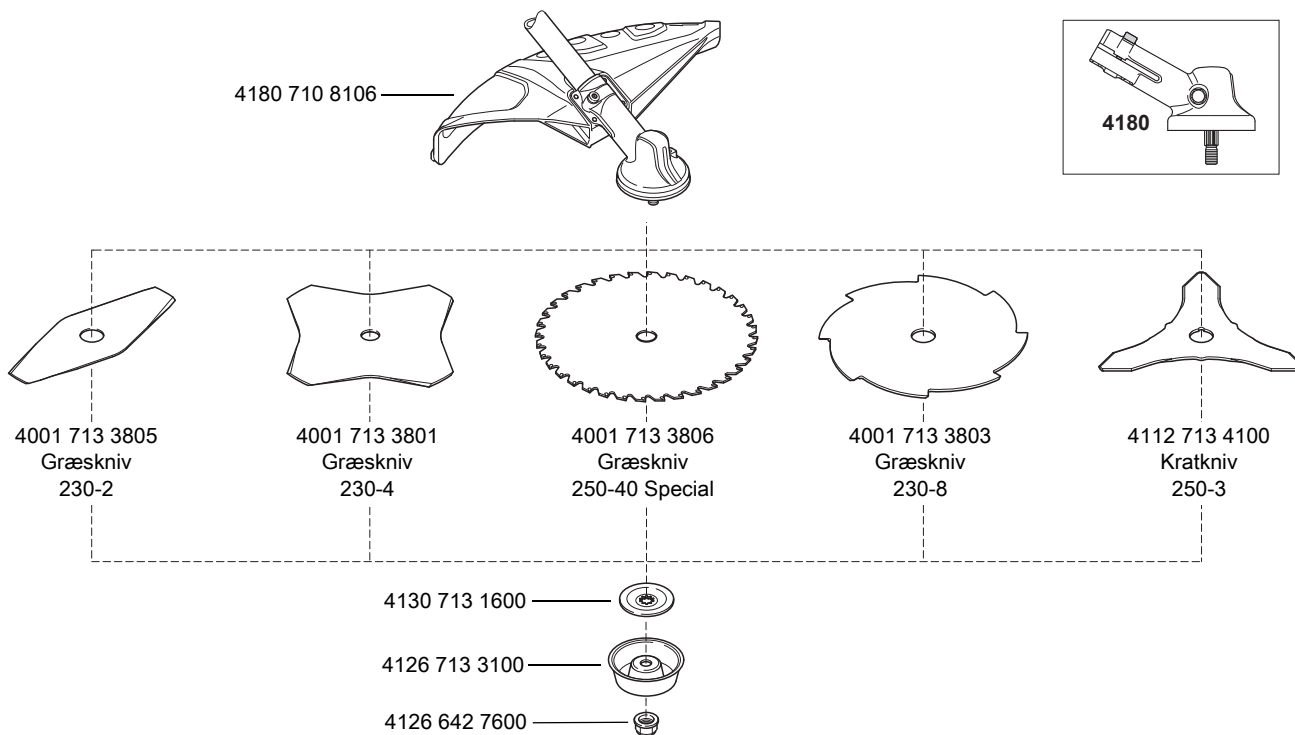

681KT987-A1

(a) fra 2015

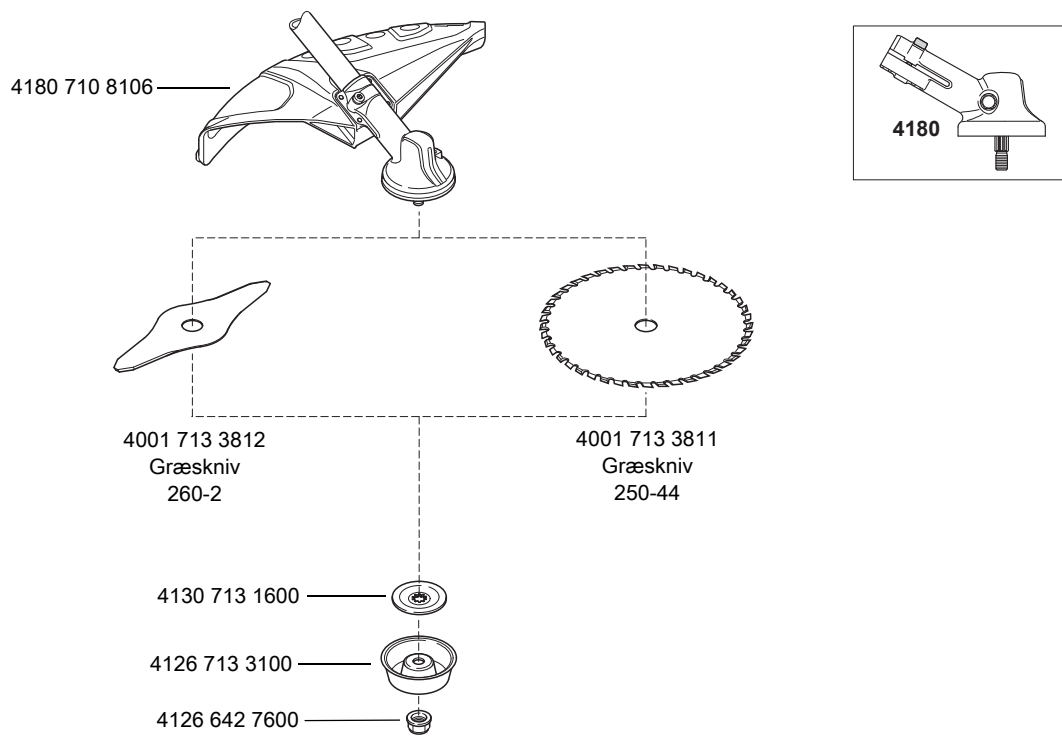

681KT1095-A1

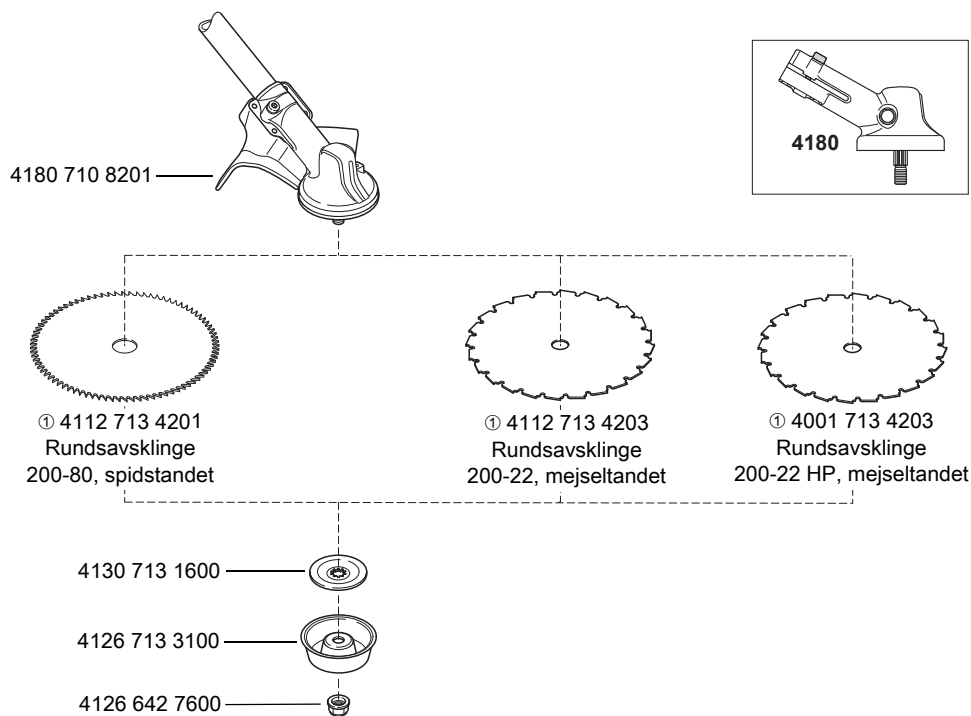

681KT998-A1

① Ikke tilladt på trimmere med specialhåndtag

(a) indtil 2015

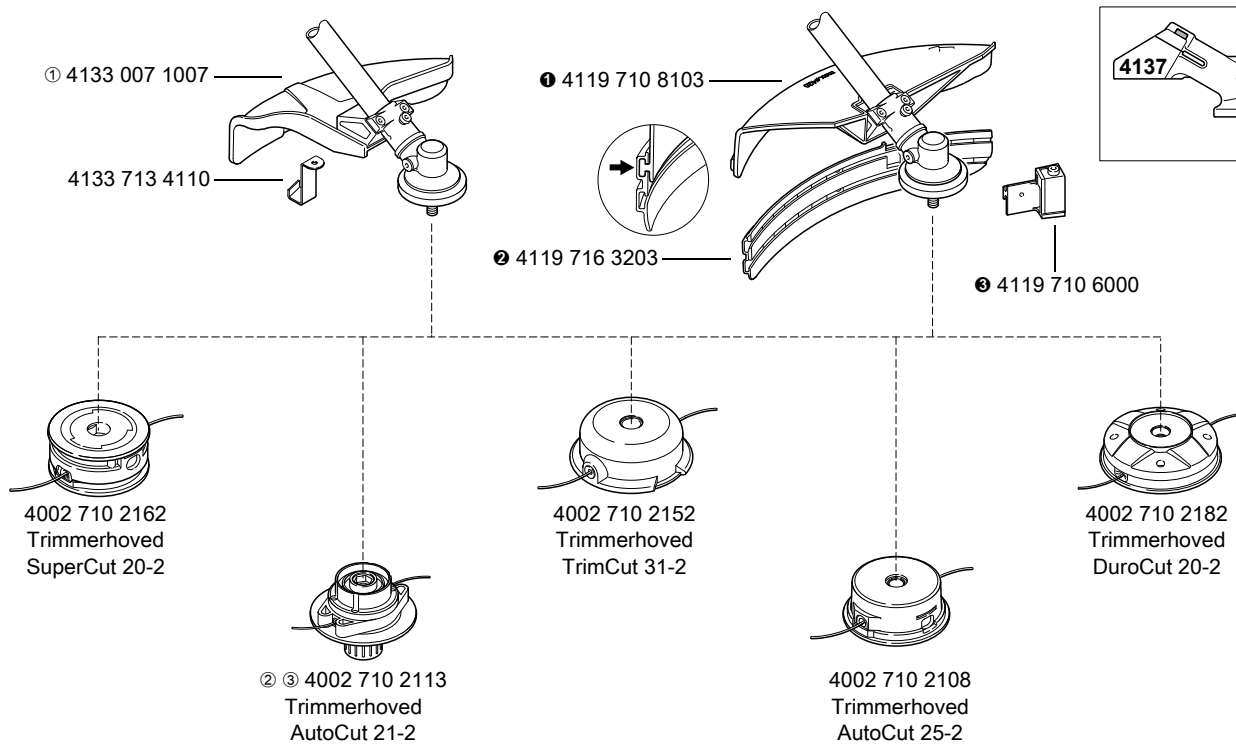

681KT915 KN

① Kun tilladt i AUS, NZ: 4133 007 1008

① + ② + ③ = 4119 007 1027

② Ikke tilladt til KM 130

③ Leveres ikke længere

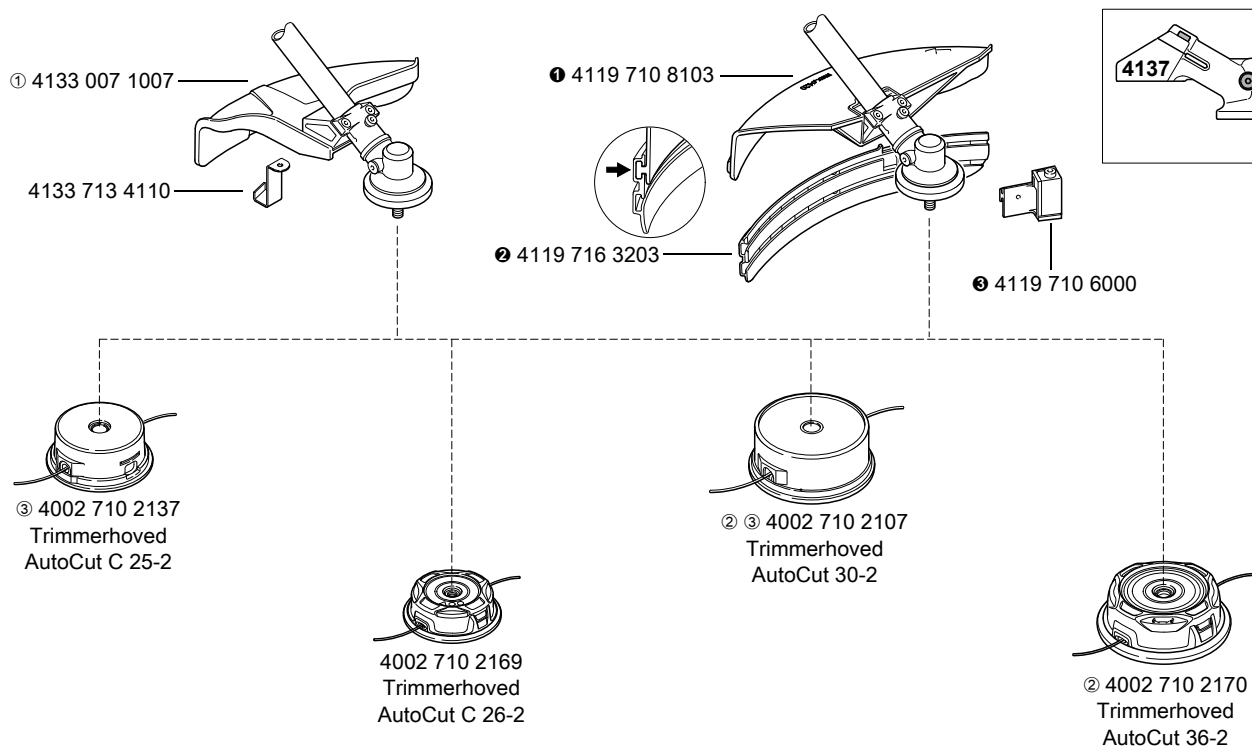

1000-GXX-3478-A0

① Kun tilladt i AUS, NZ: 4133 007 1008

① + ② + ③ = 4119 007 1027

② Kun tilladt til KM 130

③ Leveres ikke længere

(a) indtil 2015

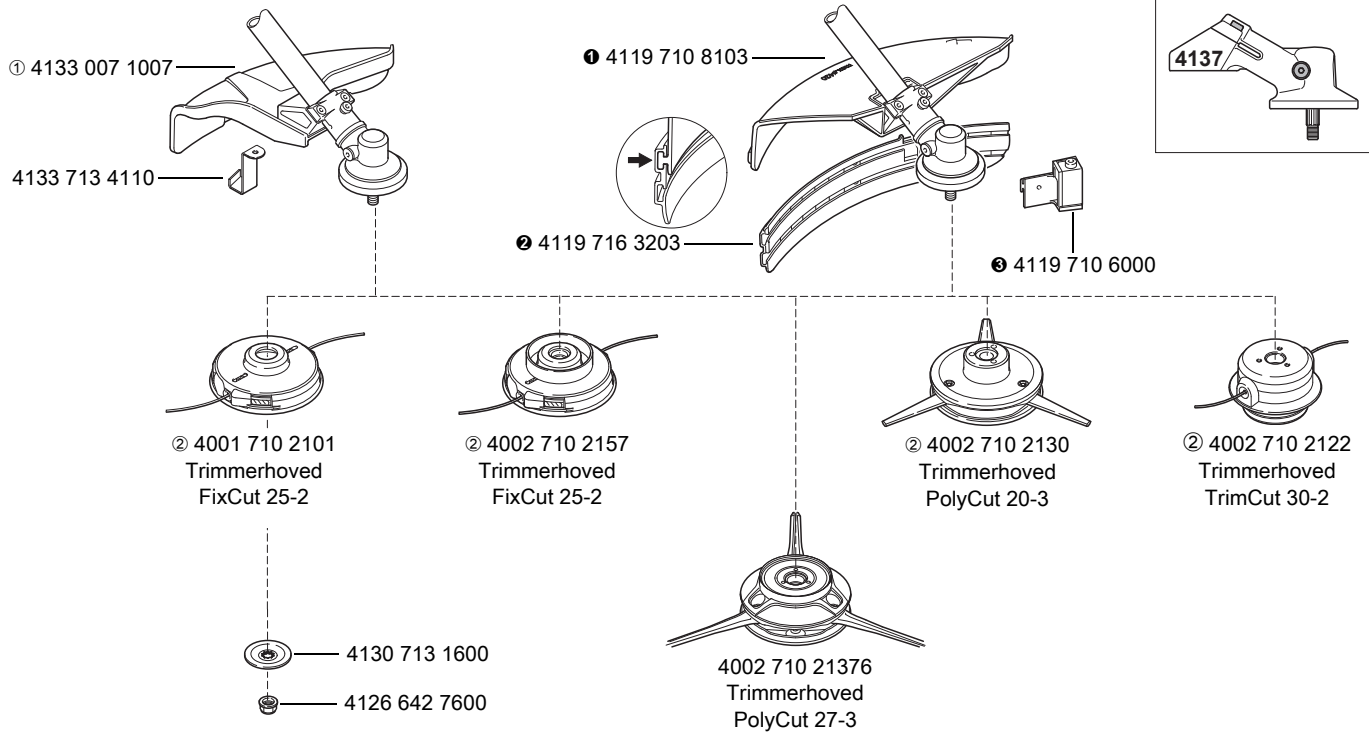

0000-GXX-5749-A1

① Kun tilladt i AUS, NZ: 4133 007 1008

② Leveres ikke længere

① + ② + ③ = 4119 007 1027

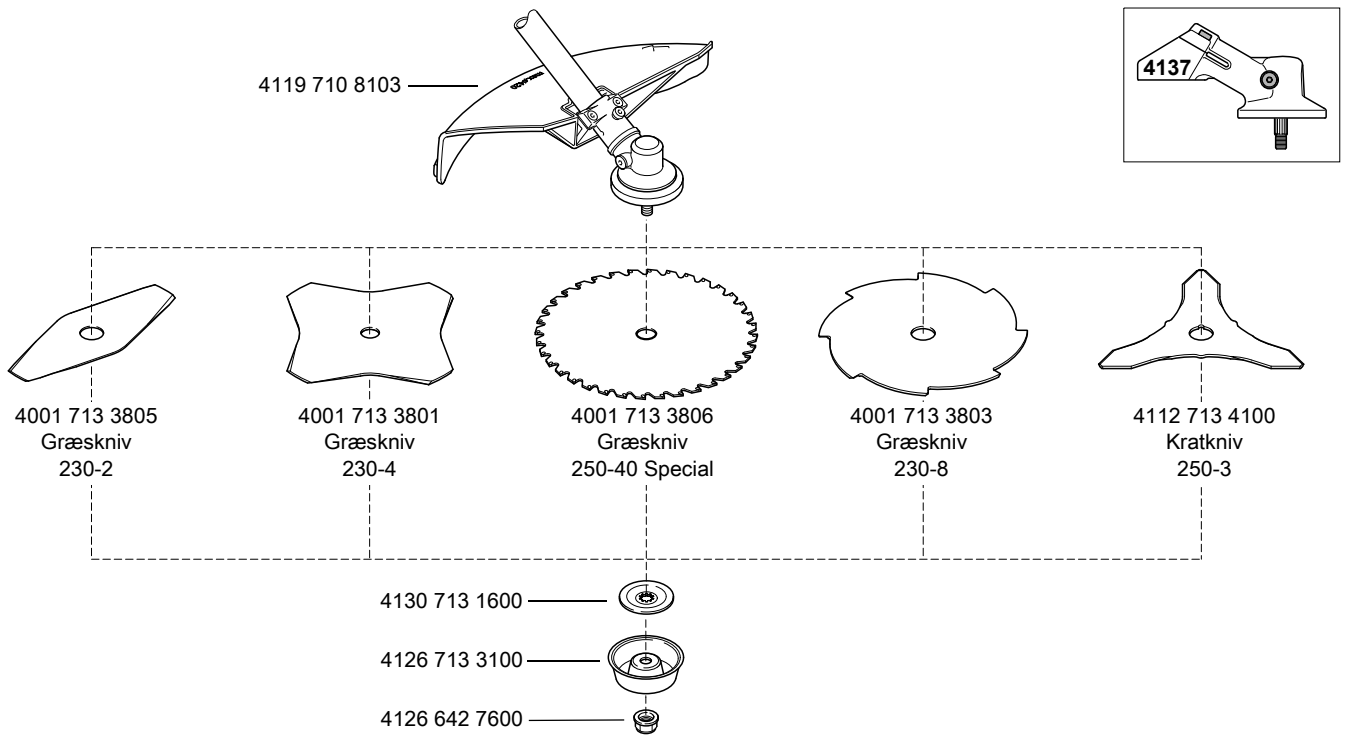

681KT918 KN

(a) indtil 2015

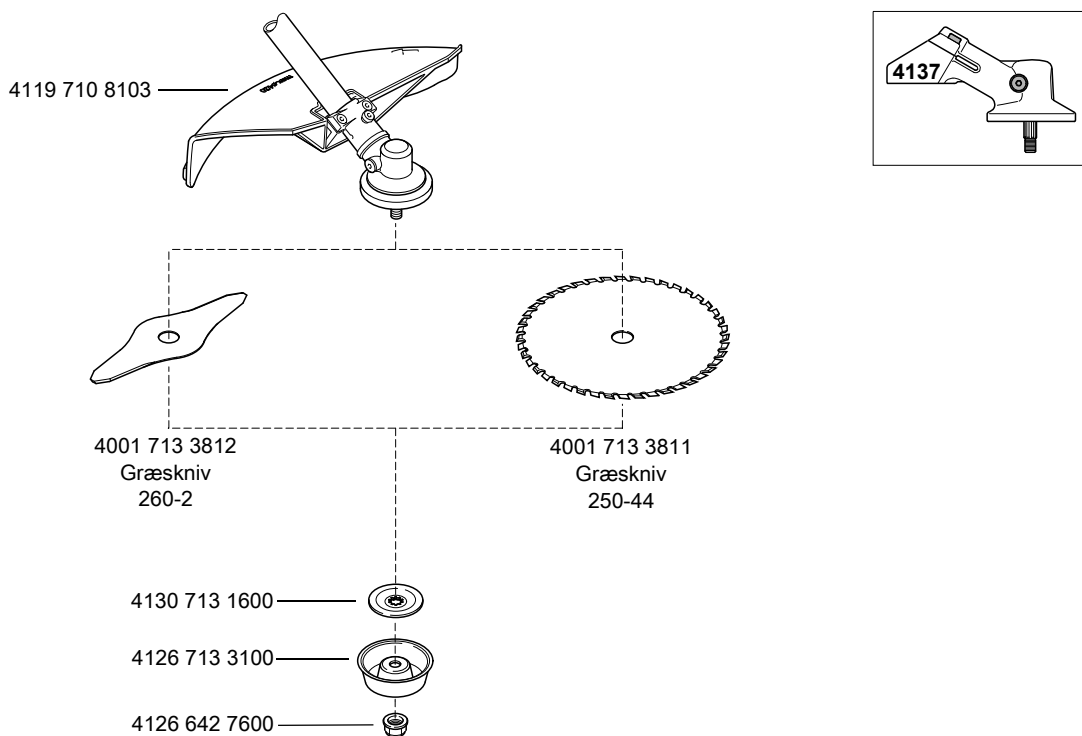

681KT1097 KN

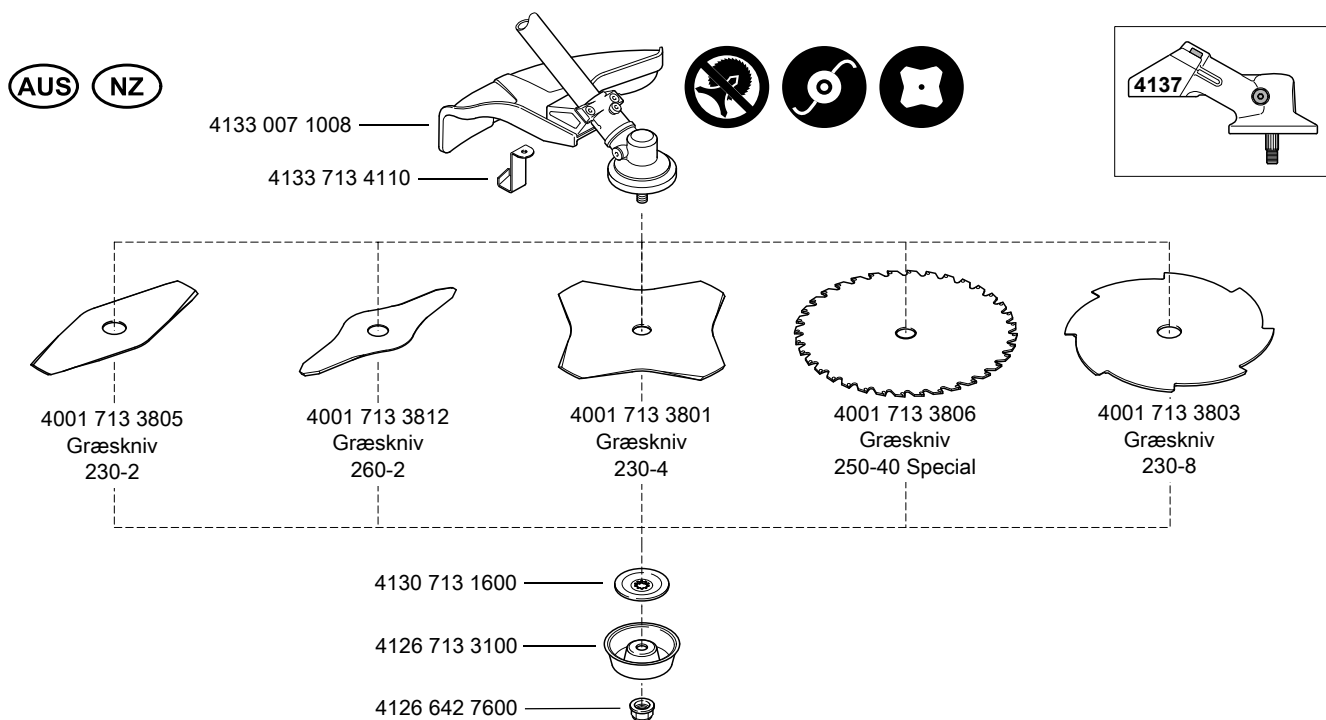

681KT1098 KN

AUS NZ

4133 007 1008

4133 713 4110

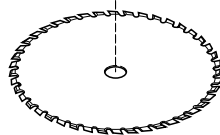
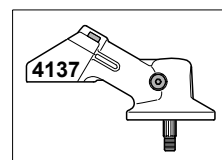
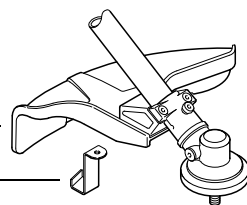

4001 713 3812

Græskniv

250-44

4130 713 1600



4126 713 3100



4126 642 7600



681KT1123 KN

❶ 4117 710 8200

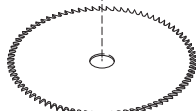
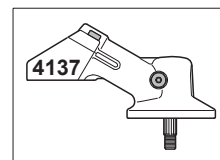
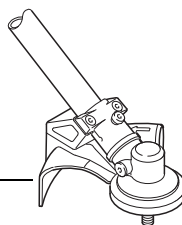

❶ 4112 713 4201
Rundsavsklinge
200-80, spidstandet

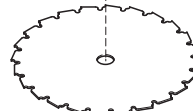

❶ 4112 713 4203
Rundsavsklinge
200-22, mejseltandet

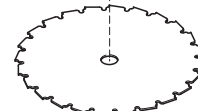

❶ 4001 713 4203
Rundsavsklinge
200-22 HP, mejseltandet

4130 713 1600



4126 713 3100



4126 642 7600



681KT920-A1

❶ Ikke tilladt på trimmere med specialhåndtag

❶ + transportbeskyttelse = 4126 007 1002 ❶

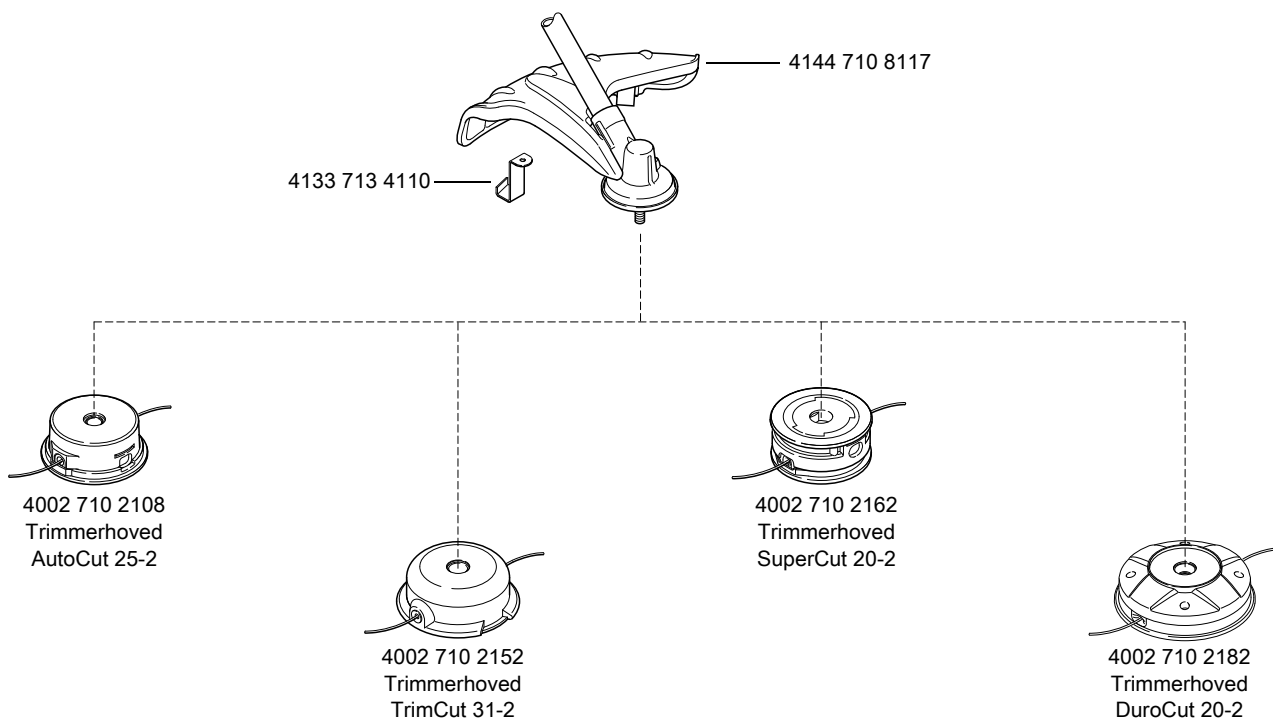

681KT933 KN

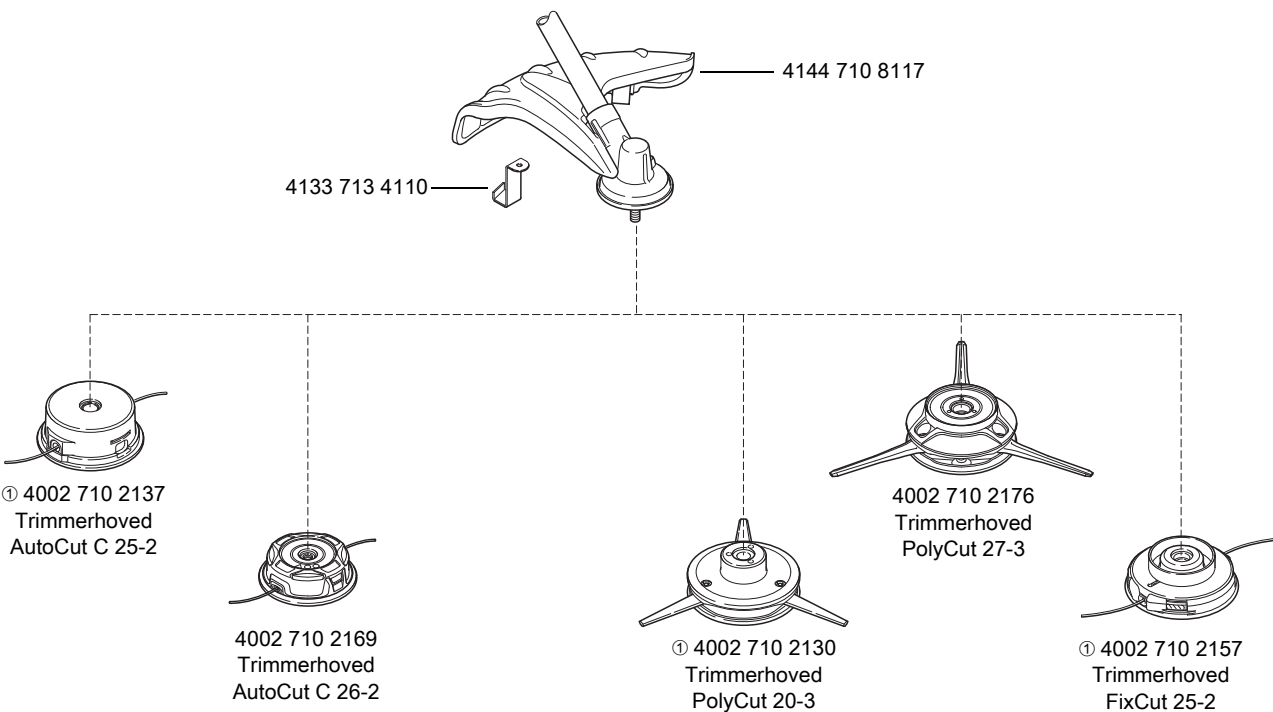

0000-GXX-5750-A0

① Leveres ikke længere

Polymatic 40-2

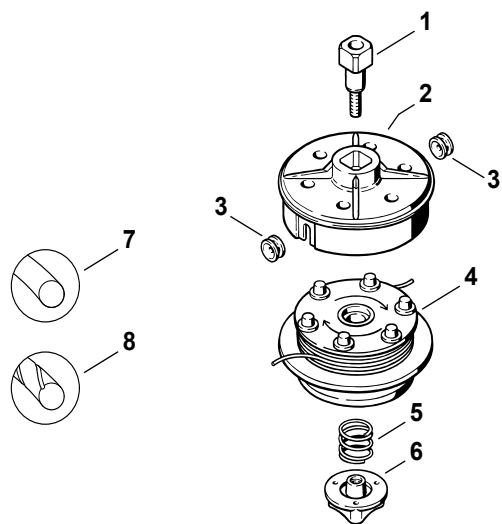

681KT682 SC

Nr.	Delnummer	Mængde	Betegnelse
	4003 710 2100	1	Trimmerhoved Polymatic 40-2 (C)
			□ 1 - 8
1	4003 713 6500	1	Kraveskrue
2	4110 713 3600	1	Spolehus
3	4110 713 8300	2	Hylse
4	4110 713 3000	1	Spoleindsats
5	0000 997 2300	1	Trykfeder
6	4110 713 6801	1	Stjernemøtrik venstre side
7		2	Rund trimmertråd Ø 2,4 mm x 2,5 m (D)
	0000 930 2338	1	Rund trimmertråd Ø 2,4 mm x 14,6 m (A,B)
	0000 930 2528	1	Rund trimmertråd Ø 2,4 mm x 15 m (A,B)
8		2	Rund trimmertråd, støjsvag Ø 2,4 mm x 2,5 m (B)
	0000 930 2419	1	Rund trimmertråd, støjsvag Ø 2,4 mm x 14 m (A,B)

TrimCut 30-2

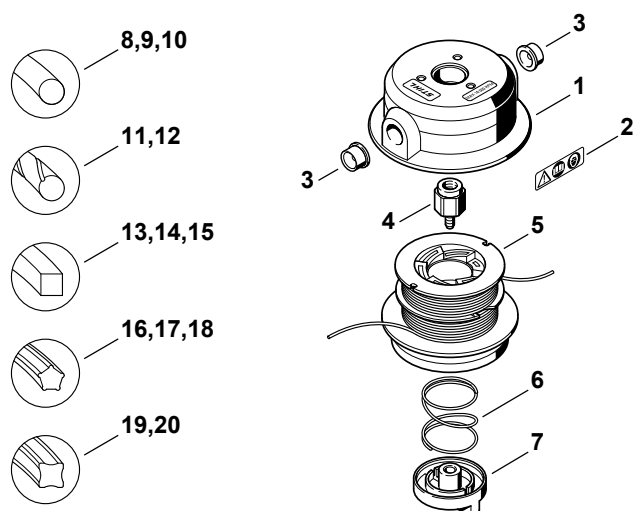

681KT67Z SC

Nr.	Delnummer	Mængde	Betegnelse
	4002 710 2122	1	Trimmerhoved TrimCut 30-2 (C)
			□ 1 - 7, 11
1	4002 710 3600	1	Spolehus ? 2, 3
2	0000 967 3706	1	Advarselhenviisning, piktogrammer
3	4002 713 8302	2	Hylse
4	4002 713 6502	1	Kraveskrue
5	4002 713 3016	1	Spoleindsats
6	0000 997 3800	1	Trykfjeder
7	4002 740 6700	1	Stjernemøtrik venstre side
8		2	Rund trimmertråd Ø 2,4 mm x 3,5 m (B)
	0000 930 2338	1	Rund trimmertråd Ø 2,4 mm x 14,6 m (A,B)
9		2	Rund trimmertråd Ø 2,7 mm x 3,5 m (B)
	0000 930 2341	1	Rund trimmertråd Ø 2,7 mm x 9,8 m (A,B)
10		2	Rund trimmertråd Ø 3 mm x 2,5 m (B)
	0000 930 2344	1	Rund trimmertråd Ø 3 mm x 53 m (A,B)
11		2	Rund trimmertråd, støjsvag Ø 2,4 mm x 5 m
	0000 930 2419	1	Rund trimmertråd, støjsvag Ø 2,4 mm x 14 m (A,B)
12		2	Rund trimmertråd, støjsvag Ø 2,7 mm x 3,5 m (B)
	0000 930 2422	1	Rund trimmertråd, støjsvag Ø 2,7 mm x 9 m (A,B)
13		2	Kvadratisk trimmertråd Ø 2,4 mm x 5 m (A,B)
	0000 930 2640	1	Kvadratisk trimmertråd Ø 2,4 mm x 41 m (A,B)
14		2	Kvadratisk trimmertråd Ø 2,7 mm x 3,5 m (B)
	0000 930 2642	1	Kvadratisk trimmertråd Ø 2,7 mm x 32 m (A,B)
15		2	Kvadratisk trimmertråd Ø 3 mm x 2,5 m (B)
	0000 930 2644	1	Kvadratisk trimmertråd Ø 3 mm x 53 m (A,B)
16		2	5-kantet trimmertråd Ø 2,4 mm x 8 m (B)
	0000 930 3340	1	5-kantet trimmertråd Ø 2,4 mm x 48 m (A,B)

TrimCut 30-2

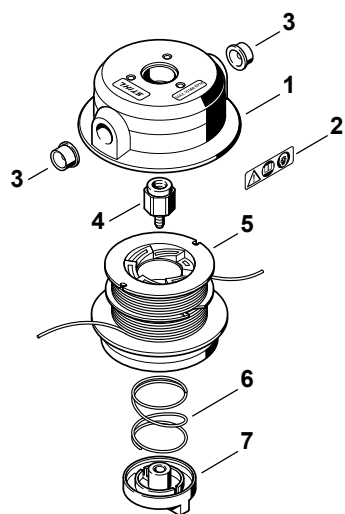
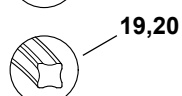
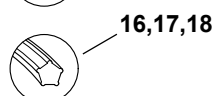
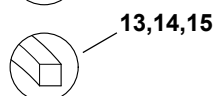
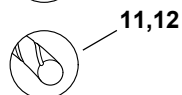
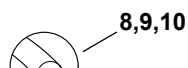

661KT672 SC

Nr.	Delnummer	Mængde	Betegnelse
	4002 710 2122	1	Trimmerhoved TrimCut 30-2 (C)
			□ 1 - 7, 11
17		2	5-kantet trimmertråd Ø 2,7 mm x 3,5 m (A,B)
	0000 930 3343	1	5-kantet trimmertråd Ø 2,7 mm x 77 m (A,B)
18		2	5-kantet trimmertråd Ø 3 mm x 2,5 m (A,B)
	0000 930 3344	1	5-kantet trimmertråd Ø 3 mm x 58 m (A,B)
19		2	X-formet trimmertråd Ø 2,4 mm x 5 m (B)
	0000 930 3410	1	X-formet trimmertråd Ø 2,4 mm x 83 m (A,B) USA
20		2	X-formet trimmertråd Ø 2,7 mm x 3,5 m (A,B)
	0000 930 3411	1	X-formet trimmertråd Ø 2,7 mm x 65 m (A,B) USA

TrimCut 31-2

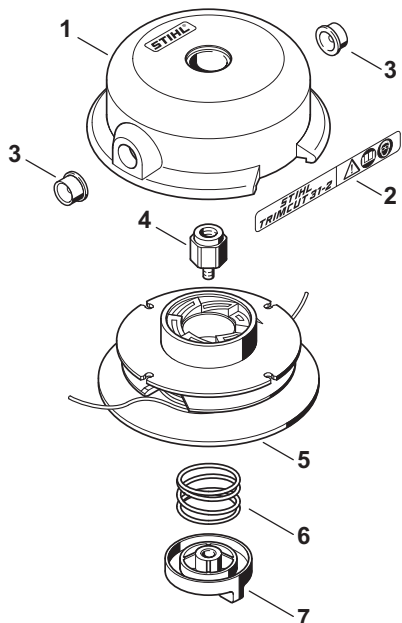
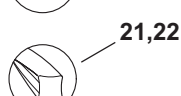
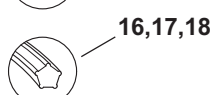
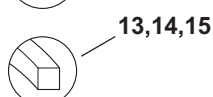
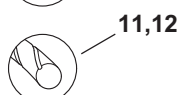
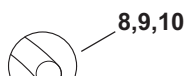

661K1110 SC

Nr.	Delnummer	Mængde	Betegnelse
	4002 710 2152	1	Trimmerhoved TrimCut 31-2
			□ 1 - 7
1	4002 713 3602	1	Spolehus
2	4002 967 4617	1	Henvisningsskilt
3	4002 713 8302	2	Hylse
4	4002 713 6502	1	Kraveskrue
	4002 710 4314	1	Spole ? 5
5	4002 713 3004	1	Spoleindsats
6	0000 997 3800	1	Trykfjeder
7	4002 740 6701	1	Stjernemøtrik venstre side
8	0000 930 2338	1	Rund trimmertråd Ø 2,4 mm x 14,6 m (B)
9	0000 930 2341	1	Rund trimmertråd Ø 2,7 mm x 9,8 m (B)
10	0000 930 2344	1	Rund trimmertråd Ø 3 mm x 53 m (B)
11	0000 930 2419	1	Rund trimmertråd, støjsvag Ø 2,4 mm x 14 m (B)

TrimCut 31-2

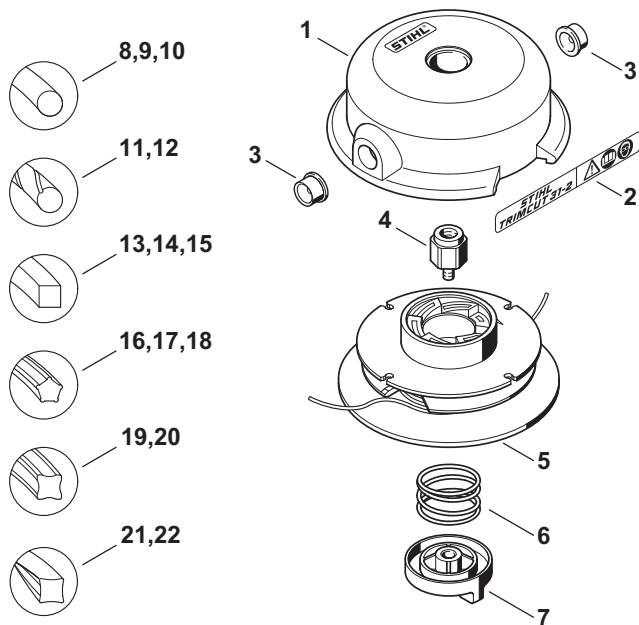

681K1110 SC

Nr.	Delnummer	Mængde	Betegnelse
	4002 710 2152	1	Trimmerhoved TrimCut 31-2 □ 1 - 7
12	0000 930 2422	1	Rund trimmertråd, støjsvag Ø 2,7 mm x 9 m (B)
13	0000 930 2640	1	Kvadratisk trimmertråd Ø 2,4 mm x 41 m (B)
14	0000 930 2642	1	Kvadratisk trimmertråd Ø 2,7 mm x 32 m (B)
15	0000 930 2644	1	Kvadratisk trimmertråd Ø 3 mm x 53 m (B)
16	0000 930 3340	1	5-kantet trimmertråd Ø 2,4 mm x 48 m (B)
17	0000 930 3343	1	5-kantet trimmertråd Ø 2,7 mm x 77 m (B)
18	0000 930 3344	1	5-kantet trimmertråd Ø 3 mm x 58 m (B)
19	0000 930 3410	1	X-formet trimmertråd Ø 2,4 mm x 83 m (B) USA
20	0000 930 3411	1	X-formet trimmertråd Ø 2,7 mm x 65 m (B) USA
21	0000 930 4301	1	Trimmertråd CF3 Pro Ø 2,7 mm x 26 m 3K (B)
22	0000 930 4302	1	Trimmertråd CF3 Pro Ø 3,0 mm x 21 m 3K (B)

TrimCut 40-2

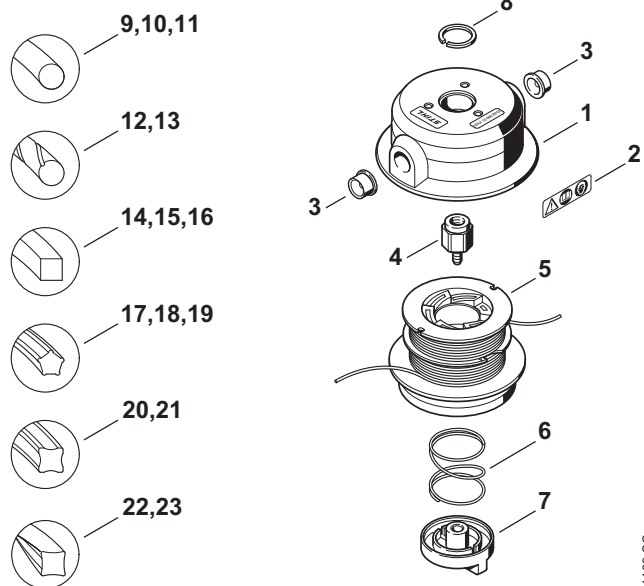

681KT1109 SC

Nr.	Delnummer	Mængde	Betegnelse
	4003 710 2101	1	Trimmerhoved TrimCut 40-2
			□ 1 - 8
1	4002 710 3600	1	Spolehus ? 2, 3
2	0000 967 3706	1	Advarselhenvi sning piktogrammer
3	4002 713 8302	2	Hylse
4	4003 713 6501	1	Kraveskrue M12x1,5 venstre side
5	4002 713 3016	1	Spoleindsats
6	0000 997 3800	1	Trykfjeder
7	4002 740 6700	1	Stjernemøtrik venstre side
8	4111 716 9300	1	Ring
9	0000 930 2338	1	Rund trimmertråd Ø 2,4 mm x 14,6 m (B)
10	0000 930 2341	1	Rund trimmertråd Ø 2,7 mm x 9,8 m (B)
11	0000 930 2344	1	Rund trimmertråd Ø 3 mm x 53 m (B)
12	0000 930 2419	1	Rund trimmertråd, støjsvag Ø 2,4 mm x 14 m (B)
13	0000 930 2422	1	Rund trimmertråd, støjsvag Ø 2,7 mm x 9 m (B)
14	0000 930 2640	1	Kvadratisk trimmertråd Ø 2,4 mm x 41 m (B)
15	0000 930 2642	1	Kvadratisk trimmertråd Ø 2,7 mm x 32 m (B)
16	0000 930 2644	1	Kvadratisk trimmertråd Ø 3 mm x 53 m (B)
17	0000 930 3340	1	5-kantet trimmertråd Ø 2,4 mm x 48 m (B)
18	0000 930 3343	1	5-kantet trimmertråd Ø 2,7 mm x 77 m (B)
19	0000 930 3344	1	5-kantet trimmertråd Ø 3 mm x 58 m (B)
20	0000 930 3410	1	X-formet trimmertråd Ø 2,4 mm x 83 m (B) USA
21	0000 930 3411	1	X-formet trimmertråd Ø 2,7 mm x 65 m (B) USA
22	0000 930 4301	1	Trimmertråd CF3 Pro Ø 2,7 mm x 26 m 3K (B)
23	0000 930 4302	1	Trimmertråd CF3 Pro Ø 3,0 mm x 21 m 3K (B)

TrimCut 41-2

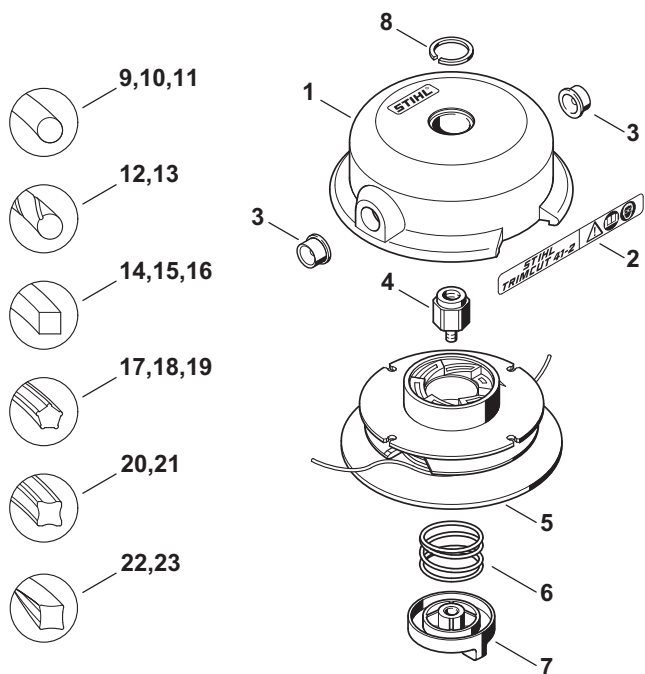

Nr.	Delnummer	Mængde	Betegnelse
	4003 710 2104	1	Trimmerhoved TrimCut 41-2
			□ 1 - 8
1	4002 713 3602	1	Spolehus
2	4003 967 4607	1	Henvisningsskilt
3	4002 713 8302	2	Hylse
4	4003 713 6501	1	Kraveskrue M12x1,5 venstre side
	4003 710 4306	1	Spole ? 5
5	4002 713 3004	1	Spoleindsats
6	0000 997 3800	1	Trykfjeder
7	4002 740 6701	1	Stjernemøtrik venstre side
8	4111 716 9300	1	Ring
9	0000 930 2338	1	Rund trimmertråd Ø 2,4 mm x 14,6 m (B)
10	0000 930 2341	1	Rund trimmertråd Ø 2,7 mm x 9,8 m (B)
11	0000 930 2344	1	Rund trimmertråd Ø 3 mm x 53 m (B)
12	0000 930 2419	1	Rund trimmertråd, støjsvag Ø 2,4 mm x 14 m (B)
13	0000 930 2422	1	Rund trimmertråd, støjsvag Ø 2,7 mm x 9 m (B)
14	0000 930 2640	1	Kvadratisk trimmertråd Ø 2,4 mm x 41 m (B)
15	0000 930 2642	1	Kvadratisk trimmertråd Ø 2,7 mm x 32 m (B)
16	0000 930 2644	1	Kvadratisk trimmertråd Ø 3 mm x 53 m (B)
17	0000 930 3340	1	5-kantet trimmertråd Ø 2,4 mm x 48 m (B)
18	0000 930 3343	1	5-kantet trimmertråd Ø 2,7 mm x 77 m (B)
19	0000 930 3344	1	5-kantet trimmertråd Ø 3 mm x 58 m (B)
20	0000 930 3410	1	X-formet trimmertråd Ø 2,4 mm x 83 m (B)
21	0000 930 3411	1	X-formet trimmertråd Ø 2,7 mm x 65 m (B)
22	0000 930 4301	1	Trimmertråd CF3 Pro Ø 2,7 mm x 26 m 3K (B)
23	0000 930 4302	1	Trimmertråd CF3 Pro Ø 3,0 mm x 21 m 3K (B)

TrimCut 50-2

9,10,11

12,13

14,15,16

17,18,19,20

21,22

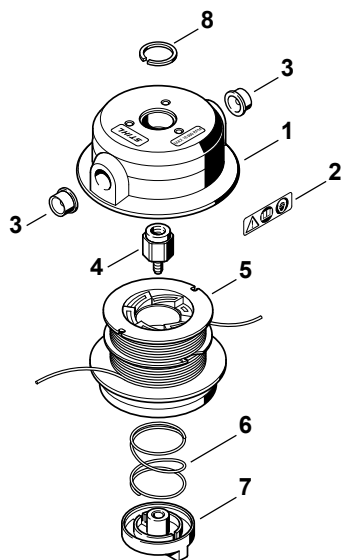

681KT676 SC

Nr.	Delnummer	Mængde	Betegnelse
	4005 710 2110	1	Trimmerhoved TrimCut 50-2 (C)
			□ 1 - 8, 13
1	4002 710 3600	1	Spolehus ? 2, 3
2	0000 967 3706	1	Advarselshenvisning, piktogrammer
3	4002 713 8302	2	Hylse
4	4005 713 6500	1	Kraveskrue M14x1,5 venstre side
5	4002 713 3016	1	Spoleindsats
6	0000 997 3800	1	Trykfjeder
7	4002 740 6700	1	Stjernemøtrik venstre side
8	4111 716 9300	1	Ring
9		2	Rund trimmertråd Ø 2,4 mm x 5 m (B)
	0000 930 2338	1	Rund trimmertråd Ø 2,4 mm x 14,6 m (A,B)
10		2	Rund trimmertråd Ø 2,7 mm x 3,5 m (B)
	0000 930 2341	1	Rund trimmertråd Ø 2,7 mm x 9,8 m (A,B)
11		2	Rund trimmertråd Ø 3 mm x 2,5 m (B)
	0000 930 2344	1	Rund trimmertråd Ø 3 mm x 53 m (A,B)
12		2	Rund trimmertråd, støjsvag Ø 2,4 mm x 5 m (B)
	0000 930 2419	1	Rund trimmertråd, støjsvag Ø 2,4 mm x 14 m (A,B)
13		2	Rund trimmertråd, støjsvag Ø 2,7 mm x 3,5 m (D)
	0000 930 2422	1	Rund trimmertråd, støjsvag Ø 2,7 mm x 9 m (A,B)
14		2	Kvadratisk trimmertråd Ø 2,4 mm x 5 m (B)
	0000 930 2640	1	Kvadratisk trimmertråd Ø 2,4 mm x 41 m (A,B)
15		2	Kvadratisk trimmertråd Ø 2,7 mm x 3,5 m (B)
	0000 930 2642	1	Kvadratisk trimmertråd Ø 2,7 mm x 32 m (A,B)
16		2	Kvadratisk trimmertråd Ø 3 mm x 2,5 m (B)
	0000 930 2644	1	Kvadratisk trimmertråd Ø 3 mm x 53 m (A,B)
17		2	5-kantet trimmertråd Ø 2,4 mm x 8 m (B)
	0000 930 3340	1	5-kantet trimmertråd Ø 2,4 mm x 48 m (A,B)
18		2	5-kantet trimmertråd Ø 2,7 mm x 3,5 m (A,B)

TrimCut 50-2

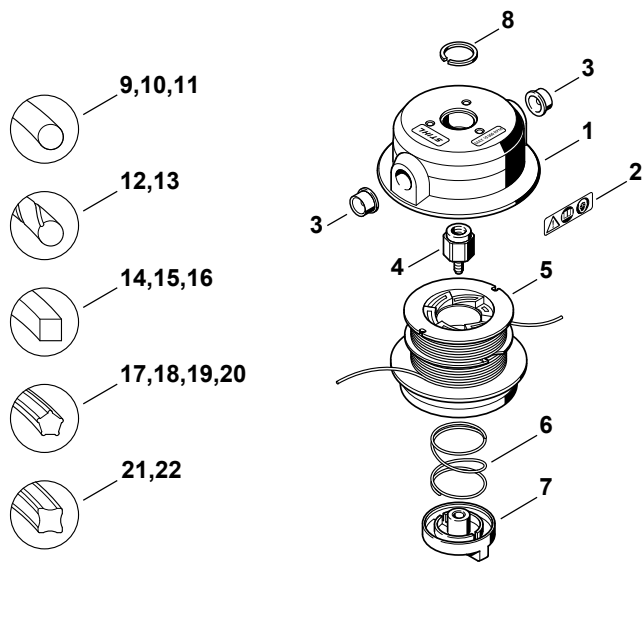

Nr.	Delnummer	Mængde	Betegnelse
	4005 710 2110	1	Trimmerhoved TrimCut 50-2 (C) □ 1 - 8, 13
	0000 930 3343	1	5-kantet trimmertråd Ø 2,7 mm x 77 m (A,B)
19		2	5-kantet trimmertråd Ø 3 mm x 2,5 m (B)
	0000 930 3344	1	5-kantet trimmertråd Ø 3 mm x 58 m (A,B)
20		1	5-kantet trimmertråd Ø 3,3 mm x 2 m (B)
	0000 930 3346	1	5-kantet trimmertråd Ø 3,3 mm x 46 m (A,B)
21		2	X-formet trimmertråd Ø 2,4 mm x 5 m (B)
	0000 930 3410	1	X-formet trimmertråd Ø 2,4 mm x 83 m (A,B) USA
22		2	X-formet trimmertråd Ø 2,7 mm x 3,5 m (B)
	0000 930 3411	1	X-formet trimmertråd Ø 2,7 mm x 65 m (A,B) USA

TrimCut 51-2

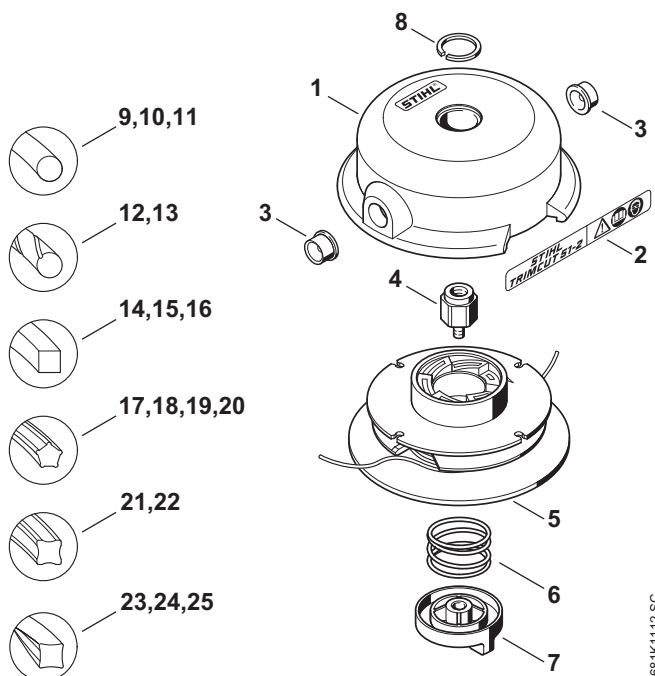

Nr.	Delnummer	Mængde	Betegnelse
	4005 710 2103	1	Trimmerhoved TrimCut 51-2 □ 1 - 8
1	4002 713 3602	1	Spolehus
2	4005 967 4603	1	Henvisningsskilt
3	4002 713 8302	2	Hylse
4	4005 713 6500	1	Kraveskrue M14x1,5 venstre side
	4003 710 4306	1	Spole ? 5
5	4002 713 3004	1	Spoleindsats
6	0000 997 3800	1	Trykfjeder
7	4002 740 6701	1	Stjernemøtrik venstre side
8	4111 716 9300	1	Ring
9	0000 930 2338	1	Rund trimmertråd Ø 2,4 mm x 14,6 m (B)
10	0000 930 2341	1	Rund trimmertråd Ø 2,7 mm x 9,8 m (B)
11	0000 930 2344	1	Rund trimmertråd Ø 3 mm x 53 m (B)
12	0000 930 2419	1	Rund trimmertråd, støjsvag Ø 2,4 mm x 14 m (B)

TrimCut 51-2

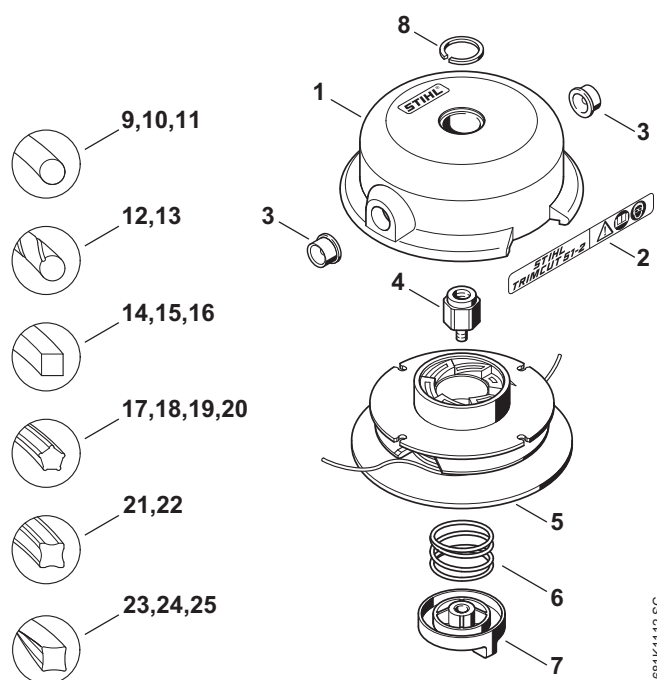

Nr.	Delnummer	Mængde	Betegnelse
	4005 710 2103	1	Trimmerhoved TrimCut 51-2
			□ 1 - 8
13	0000 930 2422	1	Rund trimmertråd, støjsvag Ø 2,7 mm x 9 m (B)
14	0000 930 2640	1	Kvadratisk trimmertråd Ø 2,4 mm x 41 m (B)
15	0000 930 2642	1	Kvadratisk trimmertråd Ø 2,7 mm x 32 m (B)
16	0000 930 2644	1	Kvadratisk trimmertråd Ø 3 mm x 53 m (B)
17	0000 930 3340	1	5-kantet trimmertråd Ø 2,4 mm x 48 m (B)
18	0000 930 3343	1	5-kantet trimmertråd Ø 2,7 mm x 77 m (B)
19	0000 930 3344	1	5-kantet trimmertråd Ø 3 mm x 58 m (B)
20	0000 930 3346	1	5-kantet trimmertråd Ø 3,3 mm x 46 m (B)
21	0000 930 3410	1	X-formet trimmertråd Ø 2,4 mm x 83 m (B) USA
22	0000 930 3411	1	X-formet trimmertråd Ø 2,7 mm x 65 m (B) USA
23	0000 930 4301	1	Trimmertråd CF3 Pro Ø 2,7 mm x 26 m 3K (B)
24	0000 930 4302	1	Trimmertråd CF3 Pro Ø 3,0 mm x 21 m 3K (B)
25	0000 930 4311	1	Trimmertråd CF3 Pro Ø 3,3 mm x 34 m 3K (B)

AutoCut 2-2

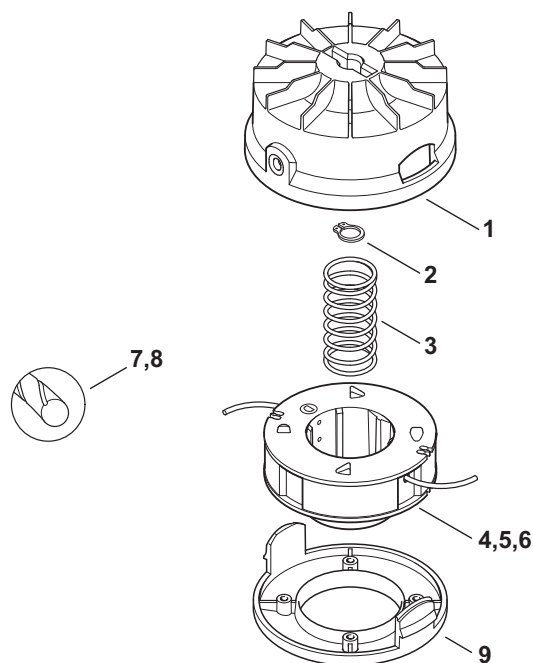

Nr.	Delnummer	Mængde	Betegnelse
	4008 710 2100	1	Trimmerhoved AutoCut 2-2
			□ 1 - 9
1	4008 710 3600	1	Spolehus
2	9455 621 0570	1	Låsering DIN471-8x0,8
3	6235 997 2200	1	Fjeder
4	4008 710 4300	1	Spoleindsats med tråd Ø 1,6 mm
5	4008 710 4301	1	Spoleindsats med tråd Ø 2,0 mm
6	4008 710 4302	1	Spoleindsats med tråd (3 stk.)
7	0000 930 2415	2	Rund trimmertråd, støjsvag 1,6 mm x 19 m (D)
8	0000 930 2416	1	Rund trimmertråd, støjsvag Ø 2 mm x 14 m (A,B)
9	4008 713 7000	1	Dæksel

4008-GKT-0000-A0

AutoCut C 4-2

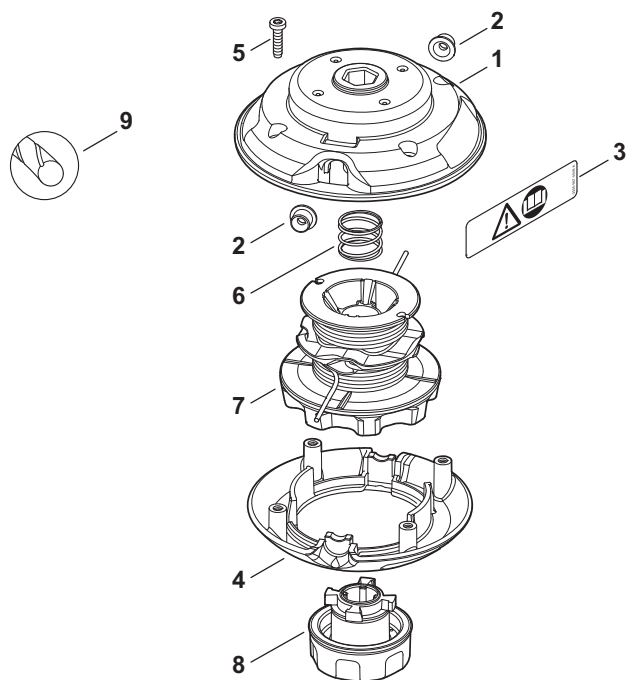

Nr.	Delnummer	Mængde	Betegnelse
	4006 710 2121	1	Trimmerhoved AutoCut C 4-2
			□ 1 - 6
1	4006 713 3201	1	Hus, overside
2	4004 713 8300	2	Hylse
3	0000 967 4048	1	Advarselshenvisning, piktogrammer
4	4006 713 3701	1	Hus, underside
5	9074 478 3025	4	Skrue IS-P4x16
6	0000 997 2015	1	Trykfjeder
7	4006 713 3000	1	Spoleindsats
8	4006 710 4001	1	Kappe
9		2	Rund trimmertråd, støjsvag Ø 2 mm x 2,5 m (D)
	0000 930 2416	1	Rund trimmertråd, støjsvag Ø 2 mm x 14 m (A,B)

681KTT28 SC

AutoCut 5-2

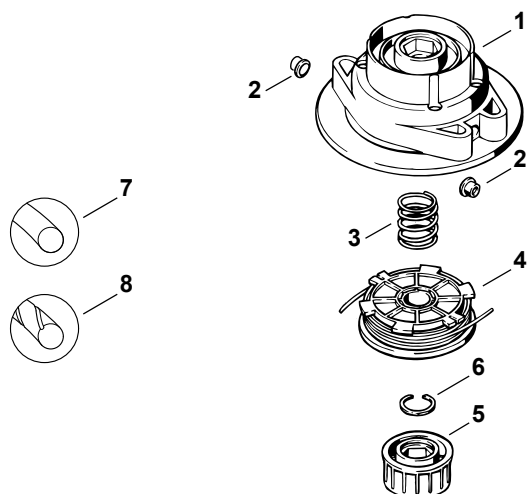

681KT549 SC

Nr.	Delnummer	Mængde	Betegnelse
	4006 710 2100	1	Trimmerhoved AutoCut 5-2 □ 1 - 7
1	4006 710 3600	1	Spolehus □ 2
2	4004 713 8300	2	Hylse
3	0000 997 3100	1	Trykfjeder
	4004 710 4300	1	Spoleindsats med snor □ 4, 7
4	4004 713 3000	1	Spoleindsats
5	4006 710 4000	1	Kappe □ 6
6	9465 620 2771	1	Sprængring 22
7		2	Rund trimmertråd Ø 2 mm x 3 m (A,B)
	0000 930 2335	1	Rund trimmertråd Ø 2 mm x 14 m (A,B)
8		2	Rund trimmertråd, støjsvag Ø 2 mm x 3 m
	0000 930 2416	1	Rund trimmertråd, støjsvag Ø 2 mm x 14 m (A,B)

AutoCut C 5-2

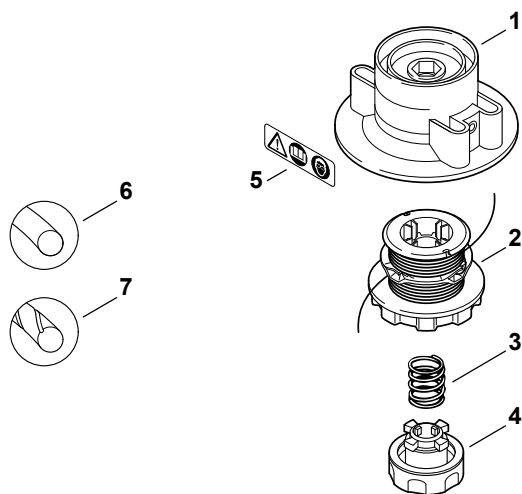

681KT547 SC

Nr.	Delnummer	Mængde	Betegnelse
	4006 710 2105	1	Trimmerhoved AutoCut C 5-2 □ 1 - 5, 7
1		1	Spolehus (D)
2	4006 713 3000	1	Spoleindsats
3	0000 997 2015	1	Trykfjeder
4	4006 710 4001	1	Kappe
5	0000 967 3706	1	Advarselshenvisning, piktogrammer
6		2	Rund trimmertråd Ø 2 mm x 2,5 m (B)
	0000 930 2335	1	Rund trimmertråd Ø 2 mm x 14 m (A,B)
7		2	Rund trimmertråd, støjsvag Ø 2 mm x 2,5 m
	0000 930 2416	1	Rund trimmertråd, støjsvag Ø 2 mm x 14 m (A,B)

AutoCut C 6-2

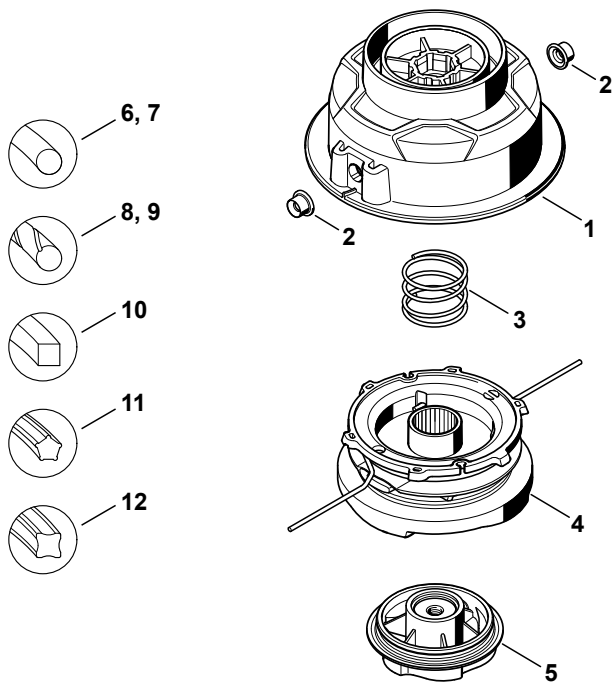

0000-GXX-2534-A0

Nr.	Delnummer	Mængde	Betegnelse
	4006 710 2126	1	Trimmerhoved AutoCut C 6-2
			□ 1, 3 - 5
1	4006 710 3602	1	Spolehus
2	4006 713 8302	2	Hylse
3	4006 997 3100	1	Trykfjeder
4	4006 820 1500	1	Spoleindsats
5	4006 710 4003	1	Kappe
6	0000 930 2335	1	Rund trimmertråd Ø 2 mm x 14 m (A,B)
7		1	Rund trimmertråd Ø 2,4 mm x 4 m
	0000 930 2338	1	Rund trimmertråd Ø 2,4 mm x 14,6 m (A,B)
8		1	Rund trimmertråd, støjsvag Ø 2 mm x 4 m
	0000 930 2416	1	Rund trimmertråd, støjsvag Ø 2 mm x 14 m (A,B)
9		1	Rund trimmertråd, støjsvag Ø 2,4 mm x 4 m
	0000 930 2419	1	Rund trimmertråd, støjsvag Ø 2,4 mm x 14 m (A,B)
10		1	Kvadratisk trimmertråd Ø 2,4 mm x 4 m
	0000 930 2640	1	Kvadratisk trimmertråd Ø 2,4 mm x 41 m (B)
11		1	5-kantet trimmertråd Ø 2,4 mm x 4 m
	0000 930 3340	1	5-kantet trimmertråd Ø 2,4 mm x 48 m (B)
12		1	X-formet trimmertråd Ø 2,4 mm x 4 m
	0000 930 3410	1	X-formet trimmertråd Ø 2,4 mm x 83 m (B)

AutoCut 11-2

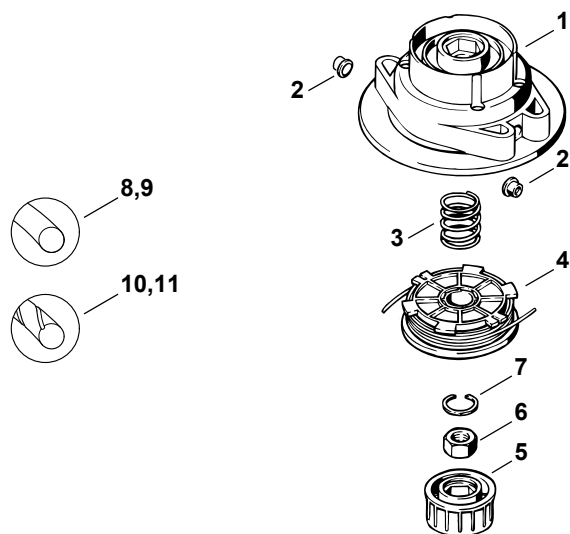

681KT588 SC

Nr.	Delnummer	Mængde	Betegnelse
	4004 710 2105	1	Trimmerhoved AutoCut 11-2
			□ 1 - 7, 10
1	4004 710 3600	1	Spolehus □ 2
2	4004 713 8300	2	Hylse
3	0000 997 2100	1	Trykfeder
	4004 710 4304	1	Spoleindsats med snor □ 4, 10
4	4004 713 3000	1	Spoleindsats
5	4004 710 4000	1	Kappe □ 6, 7
6	9210 260 1400	1	Møtrik DIN934-M12-8
7	9465 620 2771	1	Sprængring 22
8		2	Rund trimmertråd Ø 2 mm x 3 m (B)
	0000 930 2335	1	Rund trimmertråd Ø 2 mm x 14 m (A,B)
9		2	Rund trimmertråd Ø 2,4 mm x 2,5 m (B)
	0000 930 2338	1	Rund trimmertråd Ø 2,4 mm x 14,6 m (A,B)
10		2	Rund trimmertråd, støjsvag Ø 2 mm x 3 m
	0000 930 2416	1	Rund trimmertråd, støjsvag Ø 2 mm x 14 m (A,B)
11		2	Rund trimmertråd, støjsvag Ø 2,4 mm x 2,5 m (B)
	0000 930 2419	1	Rund trimmertråd, støjsvag Ø 2,4 mm x 14 m (A,B)

AutoCut 21-2

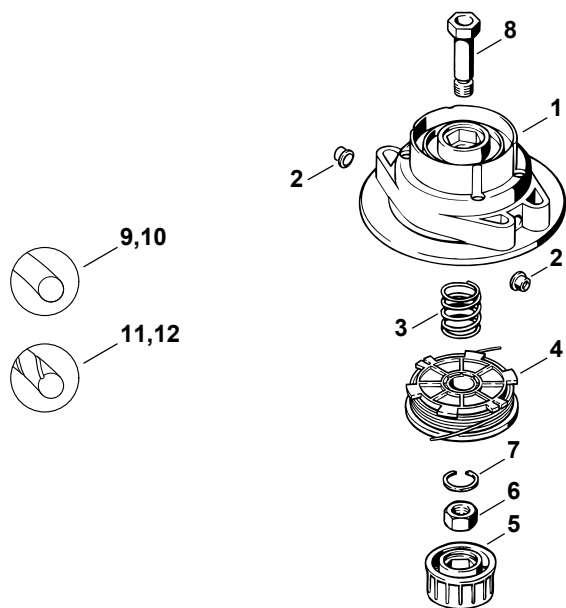

681KT590 SC

Nr.	Delnummer	Mængde	Betegnelse
	4002 710 2113	1	Trimmerhoved AutoCut 21-2 (C)
			□ 1 - 8, 10
1	4004 710 3600	1	Spolehus ? 2
2	4004 713 8300	2	Hylse
3	0000 997 2100	1	Trykfjeder
	4002 710 4307	1	Spoleindsats med snor ? 4, 10
4	4002 713 3007	1	Spoleindsats
5	4002 710 4000	1	Kappe ? 6, 7
6	9210 260 1410	1	Møtrik DIN934-M12LH-8
7	9465 620 2771	1	Sprængring 22
8	4002 713 6501	1	Kraveskrue
9		2	Rund trimmertråd Ø 2 mm x 3 m (B)
	0000 930 2335	1	Rund trimmertråd Ø 2 mm x 14 m (A,B)
10		2	Rund trimmertråd Ø 2,4 mm x 2,5 m (D)
	0000 930 2338	1	Rund trimmertråd Ø 2,4 mm x 14,6 m (A,B)
11		2	Rund trimmertråd, støjsvag Ø 2 mm x 3 m (B)
	0000 930 2416	1	Rund trimmertråd, støjsvag Ø 2 mm x 14 m (A,B)
12		2	Rund trimmertråd, støjsvag Ø 2,4 mm x 2,5 m (B)
	0000 930 2419	1	Rund trimmertråd, støjsvag Ø 2,4 mm x 14 m (A,B)

AutoCut 25-2

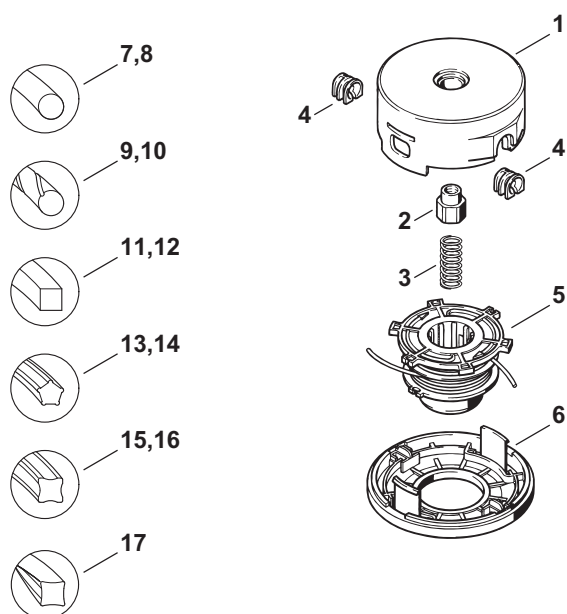

681KT1105.SC

Nr.	Delnummer	Mængde	Betegnelse
	4002 710 2108	1	Trimmerhoved AutoCut 25-2
			□ 1 - 6
1	4002 713 9608	1	Overdel
2	4002 713 6801	1	Kravemøtrik M10x1 venstre side
3	0000 997 1501	1	Skruefjeder
4	4003 713 8301	2	Hylse
	4002 710 4313	1	Spoleindsats med snor □ 5
5	4002 713 3017	1	Spoleindsats
6	4002 713 9708	1	Underdel
7	0000 930 2338	1	Rund trimmertråd Ø 2,4 mm x 14,6 m (B)
8	0000 930 2341	1	Rund trimmertråd Ø 2,7 mm x 9,8 m (B)
9	0000 930 2419	1	Rund trimmertråd, støjsvag Ø 2,4 mm x 14 m (B)
10	0000 930 2422	1	Rund trimmertråd, støjsvag Ø 2,7 mm x 9 m (B)
11	0000 930 2640	1	Kvadratisk trimmertråd Ø 2,4 mm x 41 m (B)
12	0000 930 2642	1	Kvadratisk trimmertråd Ø 2,7 mm x 32 m (B)
13	0000 930 3340	1	5-kantet trimmertråd Ø 2,4 mm x 48 m (B)
14	0000 930 3343	1	5-kantet trimmertråd Ø 2,7 mm x 77 m (B)
15	0000 930 3410	1	X-formet trimmertråd Ø 2,4 mm x 83 m (B)
16	0000 930 3411	1	X-formet trimmertråd Ø 2,7 mm x 65 m (B)
17	0000 930 4301	1	Trimmertråd CF3 Pro Ø 2,7 mm x 26 m 3K (B)

AutoCut C 25-2

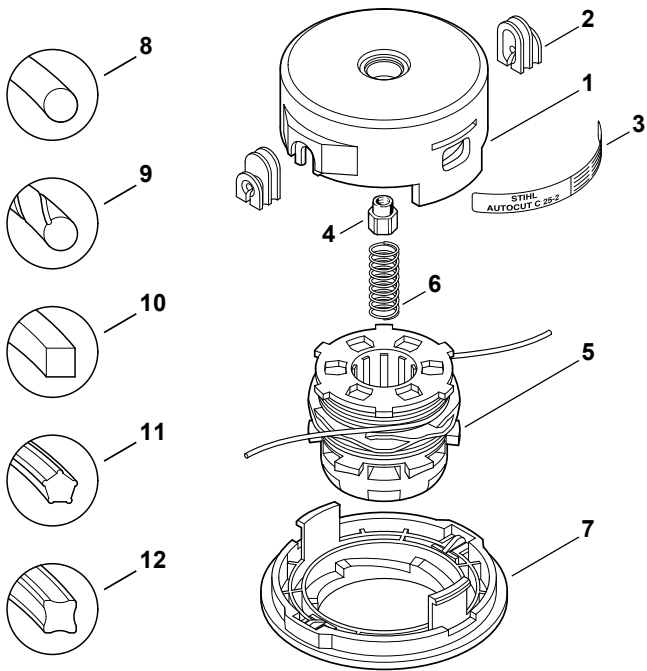

681KT548 SC

Nr.	Delnummer	Mængde	Betegnelse
	4002 710 2137	1	Trimmerhoved AutoCut C 25-2 □ 1 - 7, 9
1	4002 713 9601	1	Overdel
2	4002 713 8301	2	Hylse
3	4002 967 4608	1	Henvisningsskilt
4	4002 713 6801	1	Kravemøtrik M10x1 venstre side
	4002 710 4301	1	Spoleindsats med snor □ 5, 9
5	4002 713 3003	1	Spoleindsats
6	0000 997 1501	1	Skruefjeder
7	4002 713 9701	1	Underdel
8		2	Rund trimmertråd Ø 2,4 mm x 4 m (B)
	0000 930 2338	1	Rund trimmertråd Ø 2,4 mm x 14,6 m (A,B)
9		2	Rund trimmertråd, støjsvag Ø 2,4 mm x 4 m
	0000 930 2419	1	Rund trimmertråd, støjsvag Ø 2,4 mm x 14 m (A,B)
10		2	Kvadratisk trimmertråd Ø 2,4 mm x 4 m (B)
	0000 930 2640	1	Kvadratisk trimmertråd Ø 2,4 mm x 41 m (A,B)
11		2	5-kantet trimmertråd Ø 2,4 mm x 4 m (B)
	0000 930 3340	1	5-kantet trimmertråd Ø 2,4 mm x 48 m (A,B)
12		2	X-formet trimmertråd Ø 2,4 mm x 4 m (B)
	0000 930 3410	1	X-formet trimmertråd Ø 2,4 mm x 83 m (A,B) USA

AutoCut C 26-2

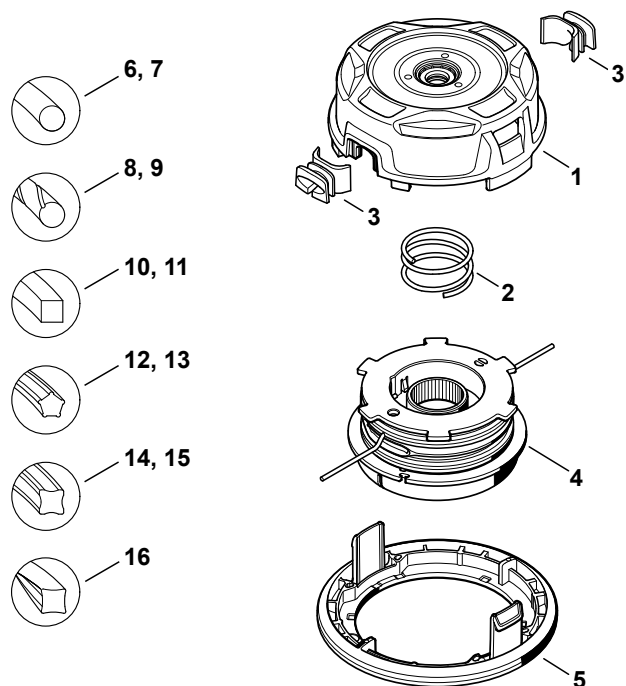

0000-GXX-2535-A0

Nr.	Delnummer	Mængde	Betegnelse
	4002 710 2169	1	Trimmerhoved AutoCut C 26-2
			□ 1 - 5
1	4002 710 9603	1	Overdel
2	0000 997 0606	1	Skruefjeder
3	4002 713 8306	2	Hylse
4	4002 740 6900	1	Spoleindsats med kappe
5	4002 713 9704	1	Underdel
6		1	Rund trimmertråd Ø 2,4 mm x 4 m
	0000 930 2338	1	Rund trimmertråd Ø 2,4 mm x 14 m (B)
7		1	Rund trimmertråd Ø 2,7 mm x 7 m
	0000 930 2341	1	Rund trimmertråd Ø 2,7 mm x 9 m (B)
8		1	Rund trimmertråd, støjsvag Ø 2,4 mm x 8 m
	0000 930 2419	1	Rund trimmertråd, støjsvag Ø 2,4 mm x 14 m (B)
9		1	Rund trimmertråd, støjsvag Ø 2,7 mm x 7 m
	0000 930 2422	1	Rund trimmertråd, støjsvag Ø 2,7 mm x 9 m (B)
10		1	Kvadratisk trimmertråd Ø 2,4 mm x 8 m
	0000 930 2640	1	Kvadratisk trimmertråd Ø 2,4 mm x 41 m (B)
11		1	Kvadratisk trimmertråd Ø 2,7 mm x 7 m
	0000 930 2642	1	Kvadratisk trimmertråd Ø 2,7 mm x 32 m (B)
12		1	5-kantet trimmertråd Ø 2,4 mm x 8 m
	0000 930 3340	1	5-kantet trimmertråd Ø 2,4 mm x 48 m (B)
13		1	5-kantet trimmertråd Ø 2,7 mm x 7 m
	0000 930 3343	1	5-kantet trimmertråd Ø 2,7 mm x 77 m (B)
14		1	X-formet trimmertråd Ø 2,4 mm x 8 m
	0000 930 3410	1	X-formet trimmertråd Ø 2,4 mm x 83 m (B)
15		1	X-formet trimmertråd Ø 2,7 mm x 7 m
	0000 930 3411	1	X-formet trimmertråd Ø 2,7 mm x 65 m (B)
16		1	Trimmertråd CF3 Pro Ø 2,7 mm x 7 m 3K
	0000 930 4301	1	Trimmertråd CF3 Pro Ø 2,7 mm x 26 m 3K (B)

AutoCut 30-2

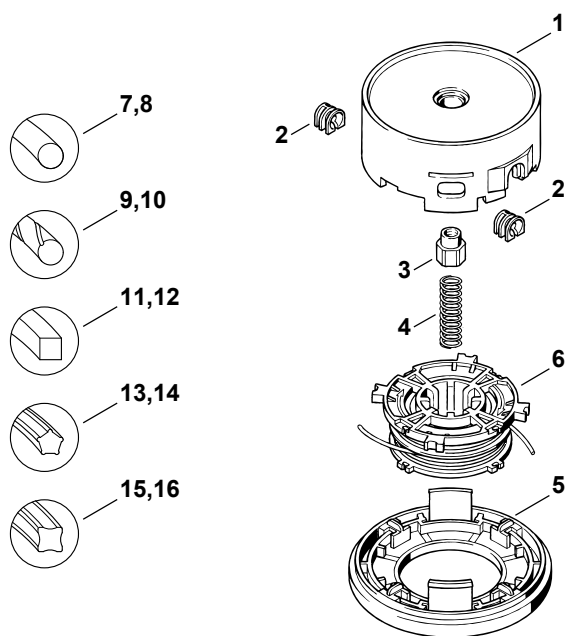

681KT592 SC

Nr.	Delnummer	Mængde	Betegnelse
	4002 710 2107	1	Trimmerhoved AutoCut 30-2
			□ 1 - 6
1	4003 713 9605	1	Overdel
2	4003 713 8301	2	Hylse
3	4002 713 6801	1	Kravemøtrik M10x1 venstre side
4	0000 997 1601	1	Trykfjeder
5	4003 713 9705	1	Underdel
	4003 710 4303	1	Spoleindsats med snor □ 6
6	4003 713 3011	1	Spoleindsats
7	0000 930 2338	1	Rund trimmertråd Ø 2,4 mm x 14 m (B)
8	0000 930 2341	1	Rund trimmertråd Ø 2,7 mm x 9 m (B)
9	0000 930 2419	1	Rund trimmertråd, støjsvag Ø 2,4 mm x 14 m (B)
10	0000 930 2422	1	Rund trimmertråd, støjsvag Ø 2,7 mm x 9 m (B)
11	0000 930 2640	1	Kvadratisk trimmertråd Ø 2,4 mm x 41 m (B)
12	0000 930 2642	1	Kvadratisk trimmertråd Ø 2,7 mm x 32 m (B)
13	0000 930 3340	1	5-kantet trimmertråd Ø 2,4 mm x 48 m (B)
14	0000 930 3343	1	5-kantet trimmertråd Ø 2,7 mm x 77 m (B)
15	0000 930 3410	1	X-formet trimmertråd Ø 2,4 mm x 83 m (B)
16	0000 930 3411	1	X-formet trimmertråd Ø 2,7 mm x 65 m (B)
17	0000 930 4301	1	Trimmertråd CF3 Pro Ø 2,7 mm x 26 m 3K (B)

AutoCut 36-2

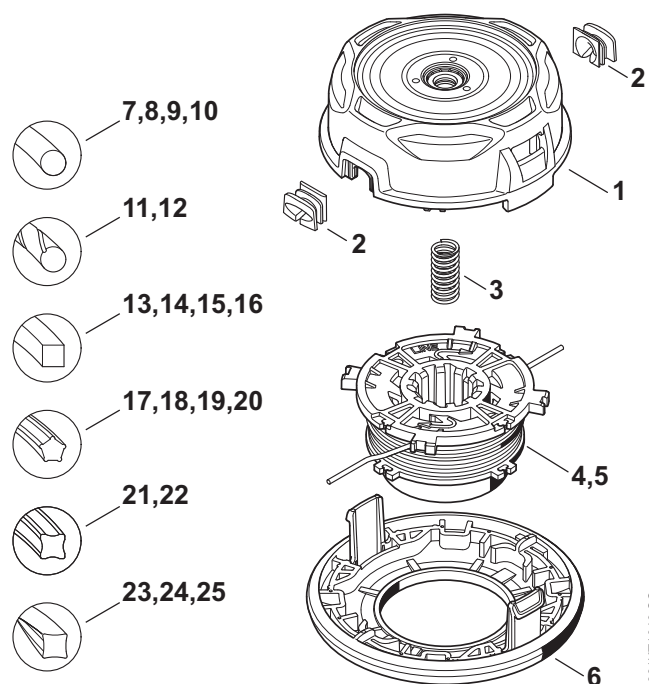

Nr.	Delnummer	Mængde	Betegnelse
	4002 710 2170	1	Trimmerhoved AutoCut 36-2
			□ 1 - 4, 6
1	4002 710 9604	1	Overdel
2	4002 713 8307	2	Hylse
3	0000 997 3102	1	Trykfjeder
4	4003 710 4307	1	Spoleindsats med snor □ 5
5	4003 713 3001	1	Spoleindsats
6	4002 713 9706	1	Underdel
7		2	Rund trimmertråd Ø 2,4 mm x 7,5 m
	0000 930 2338	1	Rund trimmertråd Ø 2,4 mm x 14,6 m (B)
8		2	Rund trimmertråd Ø 2,7 mm x 6 m
	0000 930 2341	1	Rund trimmertråd Ø 2,7 mm x 9 m (B)
9		2	Rund trimmertråd Ø 3 mm x 5 m
	0000 930 2344	1	Rund trimmertråd Ø 3 mm x 53 m (B)
10		2	Rund trimmertråd Ø 3,3 mm x 4 m
	0000 930 2345	1	Rund trimmertråd Ø 3,3 mm x 6 m (B)
11		2	Rund trimmertråd, støjsvag Ø 2,4 mm x 7,5 m
	0000 930 2419	1	Rund trimmertråd, støjsvag Ø 2,4 mm x 14 m (B)
12		2	Rund trimmertråd, støjsvag Ø 2,7 mm x 6 m
	0000 930 2422	1	Rund trimmertråd, støjsvag Ø 2,7 mm x 9 m (B)
13		2	Kvadratisk trimmertråd Ø 2,4 mm x 7,5 m
	0000 930 2640	1	Kvadratisk trimmertråd Ø 2,4 mm x 41 m (B)
14		2	Kvadratisk trimmertråd Ø 2,7 mm x 6 m (B)
	0000 930 2642	1	Kvadratisk trimmertråd Ø 2,7 mm x 32 m (B)
15		2	Kvadratisk trimmertråd Ø 3 mm x 5 m
	0000 930 2644	1	Kvadratisk trimmertråd Ø 3 mm x 53 m (B)
16		2	Kvadratisk trimmertråd Ø 3,3 mm x 4 m
	0000 930 2645	1	Kvadratisk trimmertråd Ø 3,3 mm x 4 m

AutoCut 36-2

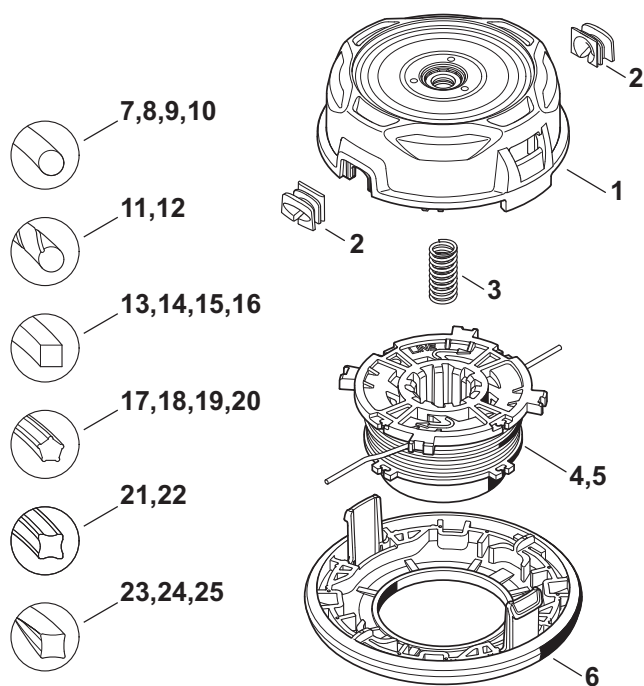

681KTT049 SC

Nr.	Delnummer	Mængde	Betegnelse
	4002 710 2170	1	Trimmerhoved AutoCut 36-2
			□ 1 - 4, 6
17		2	5-kantet trimmertråd Ø 2,4 mm x 7,5 m
	0000 930 3340	1	5-kantet trimmertråd Ø 2,4 mm x 48 m (B)
18		2	5-kantet trimmertråd Ø 2,7 mm x 6 m
	0000 930 3343	1	5-kantet trimmertråd Ø 2,7 mm x 77 m (B)
19		2	5-kantet trimmertråd Ø 3 mm x 5 m
	0000 930 3344	1	5-kantet trimmertråd Ø 3 mm x 58 m (B)
20		2	5-kantet trimmertråd Ø 3,3 mm x 4 m
	0000 930 3345	1	5-kantet trimmertråd Ø 3,3 mm x 23 m (B)
21		2	X-formet trimmertråd Ø 2,4 mm x 7,5 m
	0000 930 3410	1	X-formet trimmertråd Ø 2,4 mm x 83 m (B)
22		2	X-formet trimmertråd Ø 2,7 mm x 6 m
	0000 930 3411	1	X-formet trimmertråd Ø 2,7 mm x 65 m (B)
23		2	Trimmertråd CF3 Pro Ø 2,7 mm x 6 m
	0000 930 4301	1	Trimmertråd CF3 Pro Ø 2,7 mm x 26 m 3K (B)
24		2	Trimmertråd CF3 Pro Ø 3,0 mm x 5 m
	0000 930 4302	1	Trimmertråd CF3 Pro Ø 3,0 mm x 21 m 3K (B)
25		2	Trimmertråd CF3 Pro Ø 3,3 mm x 4 m
	0000 930 4311	1	Trimmertråd CF3 Pro Ø 3,3 mm x 34 m 3K (B)

AutoCut 40-2

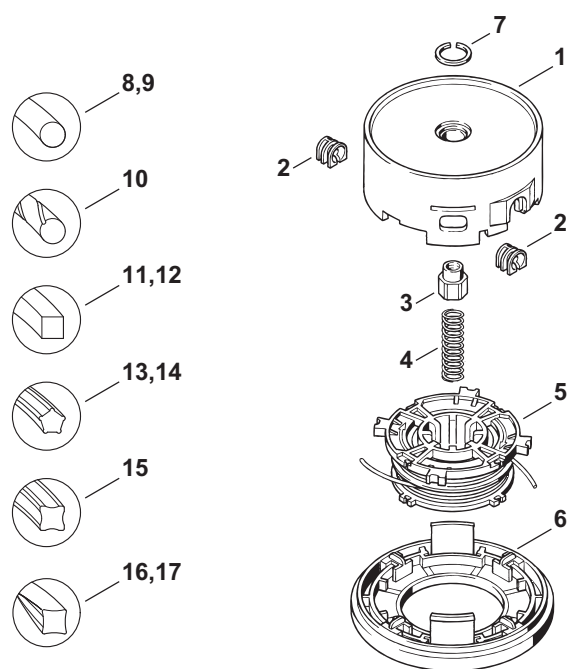

681KT1107 SC

Nr.	Delnummer	Mængde	Betegnelse
	4003 710 2125	1	Trimmerhoved AutoCut 40-2
			□ 1 - 7
1	4003 713 9605	1	Overdel
2	4003 713 8301	2	Hylse
3	4003 713 6800	1	Kravemøtrik M12x1,5 venstre side
4	0000 997 1601	1	Trykfjeder
	4003 710 4303	1	Spoleindsats med snor □ 5
5	4003 713 3011	1	Spoleindsats
6	4003 713 9705	1	Underdel
7	4111 716 9300	1	Ring
8	0000 930 2341	1	Rund trimmertråd Ø 2,7 mm x 9 m (B)
9	0000 930 2344	1	Rund trimmertråd Ø 3 mm x 53 m (B)
10	0000 930 2422	1	Rund trimmertråd, støjsvag Ø 2,7 mm x 9 m (B)
11	0000 930 2642	1	Kvadratisk trimmertråd Ø 2,7 mm x 32 m (B)
12	0000 930 2644	1	Kvadratisk trimmertråd Ø 3 mm x 53 m (B)
13	0000 930 3343	1	5-kantet trimmertråd Ø 2,7 mm x 77 m (B)
14	0000 930 3344	1	5-kantet trimmertråd Ø 3 mm x 58 m (B)
15	0000 930 3411	1	X-formet trimmertråd Ø 2,7 mm x 65 m (B)
16	0000 930 4301	1	Trimmertråd CF3 Pro Ø 2,7 mm x 26 m 3K (B)
17	0000 930 4302	1	Trimmertråd CF3 Pro Ø 3,0 mm x 21 m 3K (B)

AutoCut 46-2

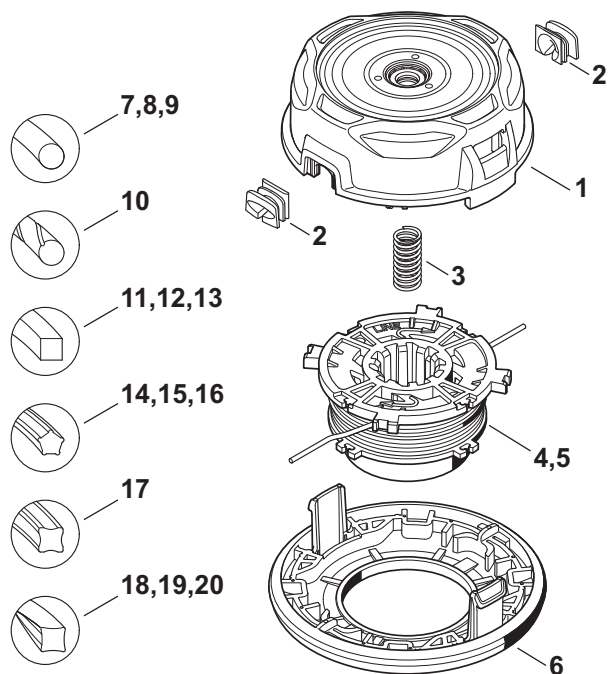

881KT1050 SC

Nr.	Delnummer	Mængde	Betegnelse
	4003 710 2115	1	Trimmerhoved AutoCut 46-2
			□ 1 - 4, 6
1	4003 710 9601	1	Overdel
2	4002 713 8307	2	Hylse
3	0000 997 3102	1	Trykfjeder
4	4003 710 4307	1	Spoleindsats med snor □ 5
5	4003 713 3001	1	Spoleindsats
6	4003 713 9701	1	Underdel
7		2	Rund trimmertråd Ø 2,7 mm x 6 m
	0000 930 2341	1	Rund trimmertråd Ø 2,7 mm x 9 m (B)
8		2	Rund trimmertråd Ø 3 mm x 5 m
	0000 930 2344	1	Rund trimmertråd Ø 3 mm x 53 m (B)
9		2	Rund trimmertråd Ø 3,3 mm x 4 m (B)
	0000 930 2345	1	Rund trimmertråd Ø 3,3 mm x 6 m (B)
10		2	Rund trimmertråd, støjsvag Ø 2,7 mm x 6 m
	0000 930 2422	1	Rund trimmertråd, støjsvag Ø 2,7 mm x 9 m (B)
11		2	Kvadratisk trimmertråd Ø 2,7 mm x 6 m
	0000 930 2642	1	Kvadratisk trimmertråd Ø 2,7 mm x 32 m (B)
12		2	Kvadratisk trimmertråd Ø 3 mm x 5 m
	0000 930 2644	1	Kvadratisk trimmertråd Ø 3 mm x 53 m (B)
13		2	Kvadratisk trimmertråd Ø 3,3 mm x 4 m
	0000 930 2645	1	Kvadratisk trimmertråd Ø 3,3 mm x 38 m (B)
14		2	5-kantet trimmertråd Ø 2,7 mm x 6 m
	0000 930 3343	1	5-kantet trimmertråd Ø 2,7 mm x 77 m (B)
15		2	5-kantet trimmertråd Ø 3 mm x 5 m
	0000 930 3344	1	5-kantet trimmertråd Ø 3 mm x 58 m (B)
16		2	5-kantet trimmertråd Ø 3,3 mm x 4 m
	0000 930 3345	1	5-kantet trimmertråd Ø 3,3 mm x 23 m (B)

AutoCut 46-2

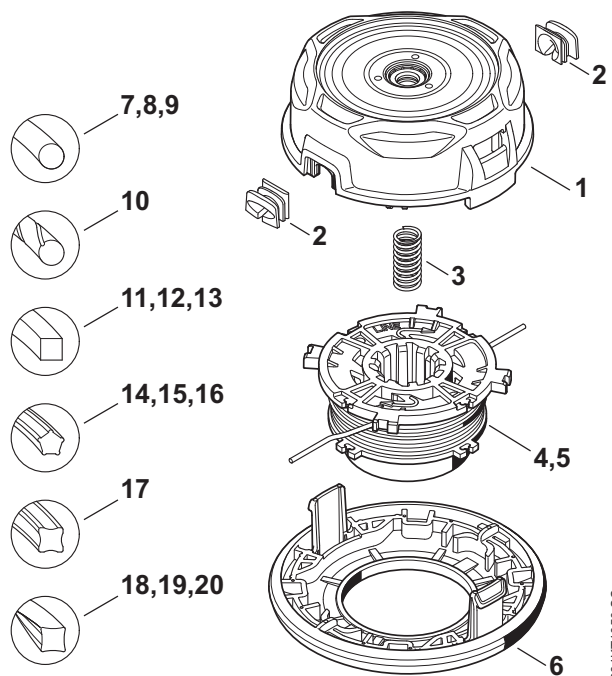

Nr.	Delnummer	Mængde	Betegnelse
	4003 710 2115	1	Trimmerhoved AutoCut 46-2
			□ 1 - 4, 6
17		2	X-formet trimmertråd Ø 2,7 mm x 6 m
	0000 930 3411	1	X-formet trimmertråd Ø 2,7 mm x 65 m (B) USA
18		2	Trimmertråd CF3 Pro Ø 2,7 mm x 6 m
	0000 930 4301	1	Trimmertråd CF3 Pro Ø 2,7 mm x 26 m 3K (B)
19		2	Trimmertråd CF3 Pro Ø 3,0 mm x 5 m
	0000 930 4302	1	Trimmertråd CF3 Pro Ø 3,0 mm x 21 m 3K (B)
20		2	Trimmertråd CF3 Pro Ø 3,3 mm x 4 m
	0000 930 4311	1	Trimmertråd CF3 Pro Ø 3,3 mm x 34 m 3K (B)

681KT1050 SC

AutoCut 40-4

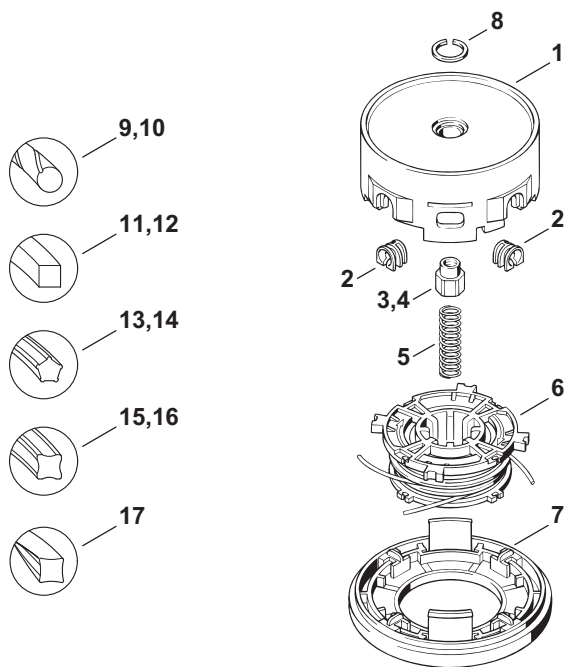

681KT114 SC

Nr.	Delnummer	Mængde	Betegnelse
	4005 710 2100	1	Trimmerhoved AutoCut 40-4
			□ 1 - 3, 5 - 8
1	4005 710 9600	1	Overdel
2	4003 713 8301	4	Hylse
3	4005 713 6800	1	Kravemøtrik M14x1,5 venstre side
4	4003 713 6801	1	Kravemøtrik M12x1,5 venstre side
5	0000 997 1601	1	Trykfjeder
	4003 710 4305	1	Spoleindsats med snor □ 6
6	4003 713 3012	1	Spoleindsats
7	4003 713 9705	1	Underdel
8	4111 716 9300	1	Ring
9	0000 930 2419	1	Rund trimmertråd, støjsvag Ø 2,4 mm x 14 m (B)
10	0000 930 2422	1	Rund trimmertråd, støjsvag Ø 2,7 mm x 9 m (B)
11	0000 930 2640	1	Kvadratisk trimmertråd Ø 2,4 mm x 41 m (B)
12	0000 930 2642	1	Kvadratisk trimmertråd Ø 2,7 mm x 32 m (B)
13	0000 930 3340	1	5-kantet trimmertråd Ø 2,4 mm x 48 m (B)
14	0000 930 3343	1	5-kantet trimmertråd Ø 2,7 mm x 77 m (B)
15	0000 930 3410	1	X-formet trimmertråd Ø 2,4 mm x 83 m (B) USA
16	0000 930 3411	1	X-formet trimmertråd Ø 2,7 mm x 65 m (B) USA
17	0000 930 4301	1	Trimmertråd CF3 Pro Ø 2,7 mm x 26 m 3K (B)

AutoCut 56-2

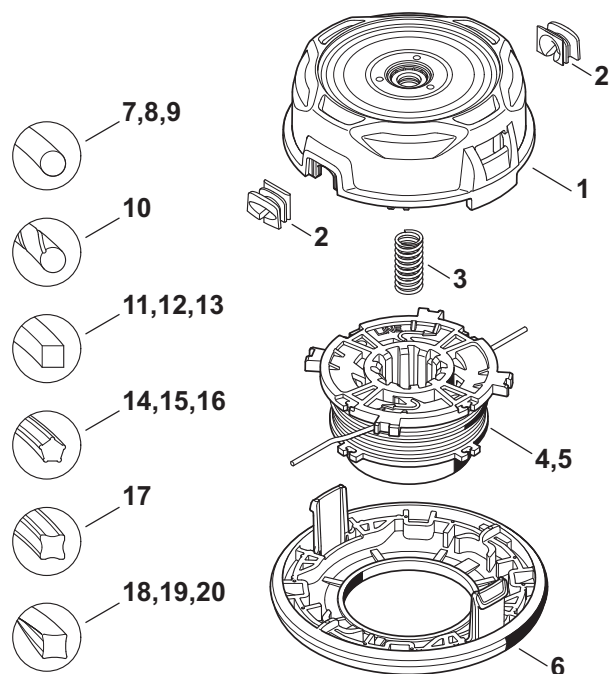

681KT1051 SC

Nr.	Delnummer	Mængde	Betegnelse
	4005 710 2107	1	Trimmerhoved AutoCut 56-2
			□ 1 - 4, 6
1	4005 710 9601	1	Overdel
2	4002 713 8307	2	Hylse
3	0000 997 3102	1	Trykfjeder
4	4003 710 4307	1	Spoleindsats med snor □ 5
5	4003 713 3001	1	Spoleindsats
6	4005 713 9701	1	Underdel
7		2	Rund trimmertråd Ø 2,7 mm x 6 m
	0000 930 2341	1	Rund trimmertråd Ø 2,7 mm x 9 m (B)
8		2	Rund trimmertråd Ø 3 mm x 5 m
	0000 930 2344	1	Rund trimmertråd Ø 3 mm x 53 m (B)
9		2	Rund trimmertråd Ø 3,3 mm x 4 m
	0000 930 2345	1	Rund trimmertråd Ø 3,3 mm x 6 m (B)
10		2	Rund trimmertråd, støjsvag Ø 2,7 mm x 6 m
	0000 930 2422	1	Rund trimmertråd, støjsvag Ø 2,7 mm x 9 m (B)
11		2	Kvadratisk trimmertråd Ø 2,7 mm x 6 m
	0000 930 2642	1	Kvadratisk trimmertråd Ø 2,7 mm x 32 m (B)
12		2	Kvadratisk trimmertråd Ø 3 mm x 5 m
	0000 930 2644	1	Kvadratisk trimmertråd Ø 3 mm x 53 m (B)
13		2	Kvadratisk trimmertråd Ø 3,3 mm x 4 m
	0000 930 2645	1	Kvadratisk trimmertråd Ø 3,3 mm x 38 m (B)
14		2	5-kantet trimmertråd Ø 2,7 mm x 6 m
	0000 930 3343	1	5-kantet trimmertråd Ø 2,7 mm x 77 m (B)
15		2	5-kantet trimmertråd Ø 3 mm x 5 m
	0000 930 3344	1	5-kantet trimmertråd Ø 3 mm x 58 m (B)
16		2	5-kantet trimmertråd Ø 3,3 mm x 4 m
	0000 930 3345	1	5-kantet trimmertråd Ø 3,3 mm x 4 m
17		2	X-formet trimmertråd Ø 2,7 mm x 6 m
	0000 930 3411	1	X-formet trimmertråd Ø 2,7 mm x 65 m (B) USA

AutoCut 56-2

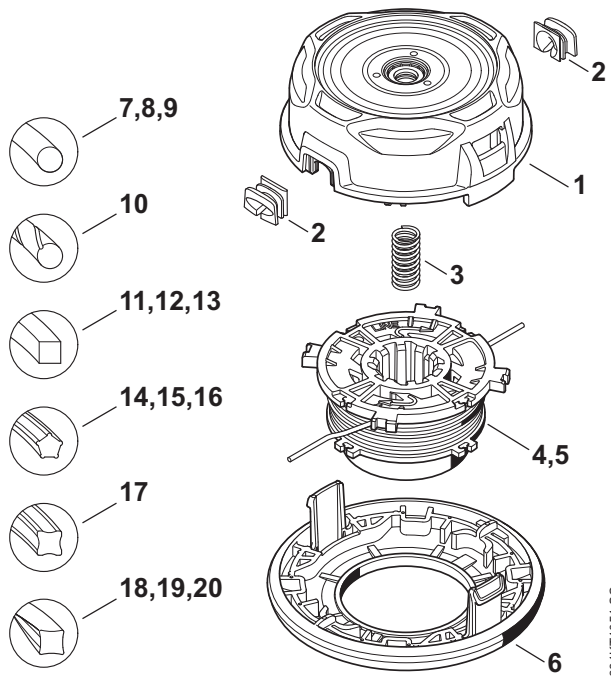

681KT1051 SC

Nr.	Delnummer	Mængde	Betegnelse
	4005 710 2107	1	Trimmerhoved AutoCut 56-2
			□ 1 - 4, 6
18		2	Trimmertråd CF3 Pro Ø 2,7 mm x 6 m
	0000 930 4301	1	Trimmertråd CF3 Pro Ø 2,7 mm x 26 m 3K (B)
19		2	Trimmertråd CF3 Pro Ø 3,0 mm x 5 m
	0000 930 4302	1	Trimmertråd CF3 Pro Ø 3,0 mm x 21 m 3K (B)
20		2	Trimmertråd CF3 Pro Ø 3,3 mm x 4 m
	0000 930 4311	1	Trimmertråd CF3 Pro Ø 3,3 mm x 34 m 3K (B)

SuperCut 20-2

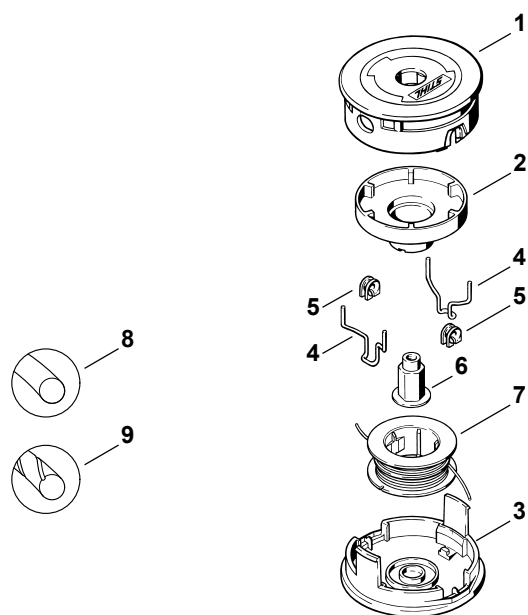

681KT597 SC

Nr.	Delnummer	Mængde	Betegnelse
	4002 710 2162	1	Trimmerhoved SuperCut 20-2
			□ 1 - 8
1	4002 710 9615	1	Overdel
2	4002 713 7315	1	Skifteskive
3	4002 713 9715	1	Underdel
4	4002 713 3400	2	Bøjle
5	4002 713 8310	2	Hylse
6	4002 713 6805	1	Kravemøtrik M10x1 venstre side
	4002 710 4309	1	Spoleindsats med snor □ 7, 8
7	4002 713 3015	1	Spoleindsats
8		2	Rund trimmertråd Ø 2,4 mm x 3 m
	0000 930 2338	1	Rund trimmertråd Ø 2,4 mm x 14 m (A,B)
9		2	Rund trimmertråd, støjsvag Ø 2,4 mm x 3 m (B)
	0000 930 2419	1	Rund trimmertråd, støjsvag Ø 2,4 mm x 14 m (A,B)

SuperCut 40-2

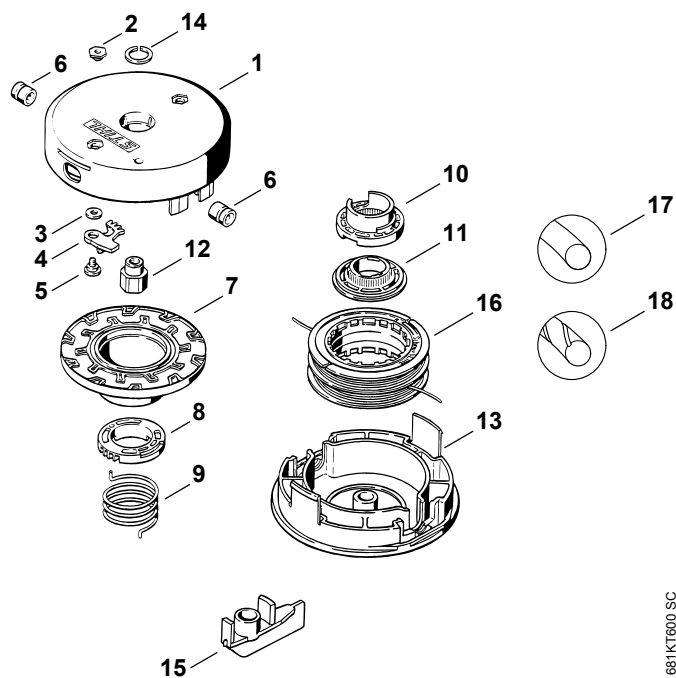

681KT600 SC

Nr.	Delnummer	Mængde	Betegnelse
	4003 710 2140	1	Trimmerhoved SuperCut 40-2
			□ 1 - 17
1	4002 713 9605	1	Overdel
2	4002 713 6802	2	Kravemøtrik
3	0000 958 0516	2	Skive
4	4002 713 7205	2	Klinke
5	4002 713 6500	2	Kraveskrue
6	4002 713 8305	2	Hylse
7	4002 713 7300	1	Skifteskive
8	4002 713 6905	1	Synkronring
9	4002 998 4000	1	Torsionsfjeder
10	4002 713 6900	1	Stillering
11	4002 713 6910	1	Tandring
12	4003 713 6800	1	Kravemøtrik M12x1,5 venstre side
13	4003 713 9700	1	Underdel
14	4111 716 9300	1	Ring
15	4002 893 1300	1	Spændenøgle
	4002 710 4300	1	Spoleindsats med snor □ 16, 17
16	4002 713 3005	1	Spoleindsats
17		2	Rund trimmertråd Ø 2,4 mm x 3,75 m
	0000 930 2338	1	Rund trimmertråd Ø 2,4 mm x 14 m (A,B)
	0000 930 2528	1	Rund trimmertråd Ø 2,4 mm x 15 m (A,B)
18		2	Rund trimmertråd, støjsvag Ø 2,4 mm x 3,75 m (B)
	0000 930 2419	1	Rund trimmertråd, støjsvag Ø 2,4 mm x 14 m (A,B)

PolyCut 2-2

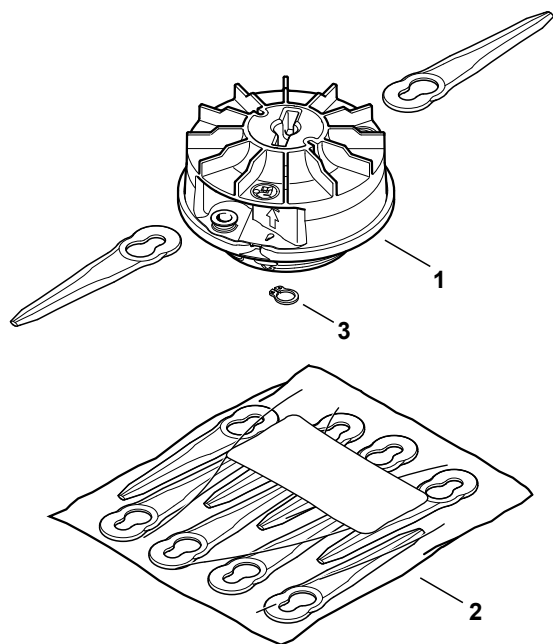

0000-GXX-2524-A0

Nr.	Delnummer	Mængde	Betegnelse
1	4008 710 2102	1	Trimmerhoved PolyCut 2-2 □ 2 - 3
2	4008 007 1000	1	Sæt med knive (8 stk.)
3	9455 621 0570	1	Låsering DIN471-8x0,8

PolyCut 5-3

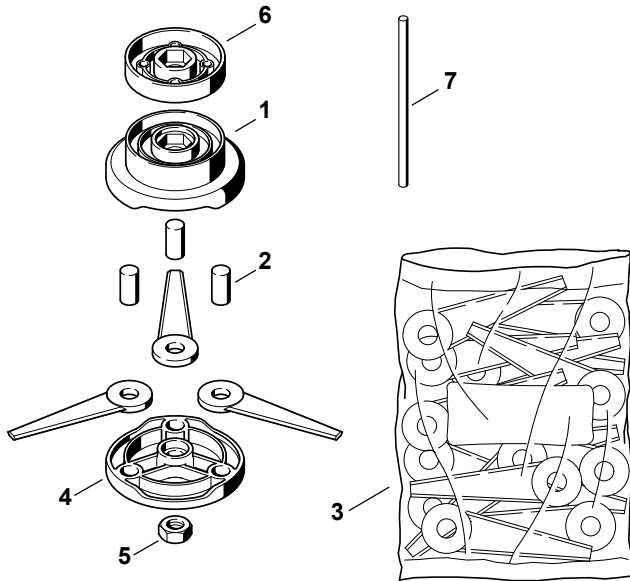

681KT601 SC

Nr.	Delnummer	Mængde	Betegnelse
	4004 710 2131	1	Trimmerhoved PolyCut 5-3
			□ 1 - 7
1	4004 713 9601	1	Overdel
2	4004 713 6600	3	Bolte
3	4111 007 1001	3	Sæt med knive (12 stk.)
4	4004 713 9701	1	Underdel
5	9211 260 1400	1	Møtrik DIN936-M12-04
6	4130 713 1501	1	Trykskive
7	4130 893 7800	1	Stikdorn

PolyCut 6-3

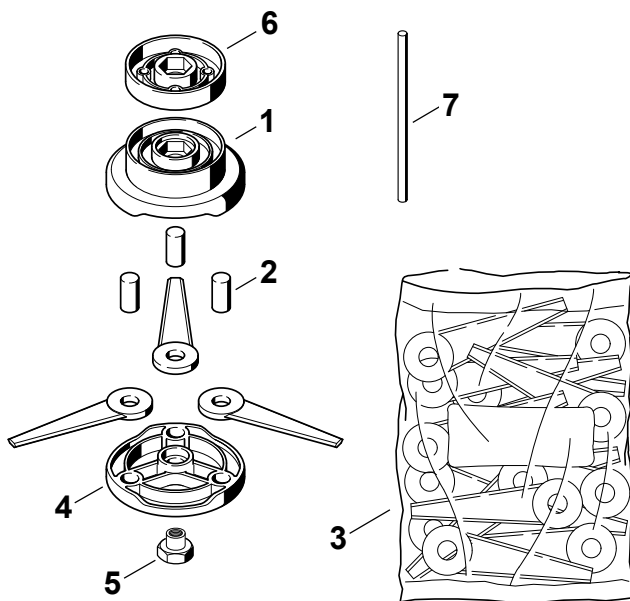

681KT602 KN

Nr.	Delnummer	Mængde	Betegnelse
	4006 710 2110	1	Trimmerhoved PolyCut 6-3
			□ 1 - 7
1	4004 713 9601	1	Overdel
2	4004 713 6600	3	Bolte
3	4111 007 1001	3	Sæt med knive (12 stk.)
4	4004 713 9701	1	Underdel
5	4006 713 6800	1	Kravemøtrik
6	4140 713 1501	1	Trykskive
7	4130 893 7800	1	Stikdorn

PolyCut 7-3

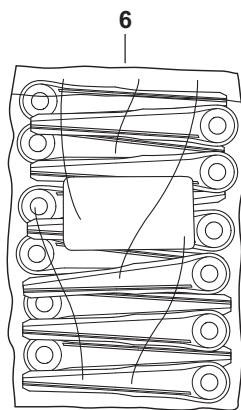
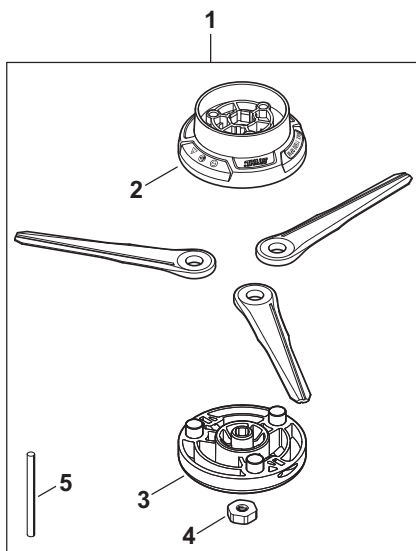

0000-GXX-6607-A0

Nr.	Delnummer	Mængde	Betegnelse
1	4006 710 2127	1	Trimmerhoved PolyCut 7-3 □ 2- 5
2	4006 710 9602	1	Overdel
3	4006 710 9700	1	Underdel
4	0000 955 0801	1	Sekskantmøtrik M8
5	4130 893 7800	1	Stikdorn
6	4002 007 1000	1	Sæt med knive (12 stk.)

PolyCut 20-3

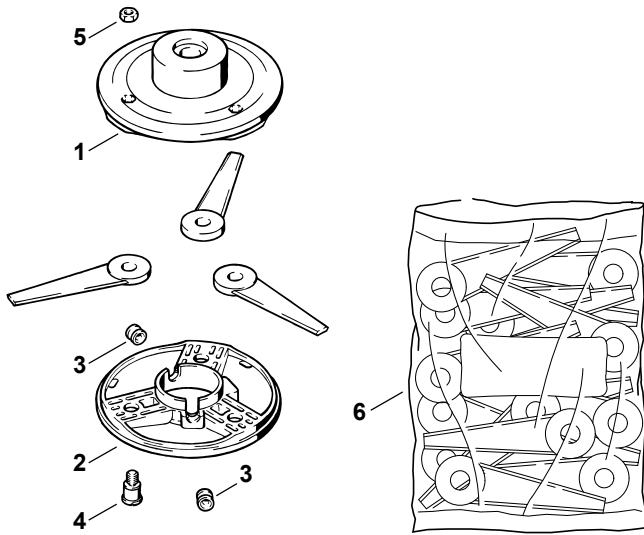

681KT657 SC

Nr.	Delnummer	Mængde	Betegnelse
	4002 710 2130	1	Trimmerhoved PolyCut 20-3
			□ 1 - 6
1	4002 710 9601	1	Overdel
2	4002 713 9700	1	Underdel
3	4002 713 8300	2	Hylse
4	4111 710 8700	3	Kraveskrue
5	9210 319 0900	3	Møtrik DIN934-M6-10
6	4111 007 1001	1	Sæt med knive (12 stk.)

PolyCut 27-3

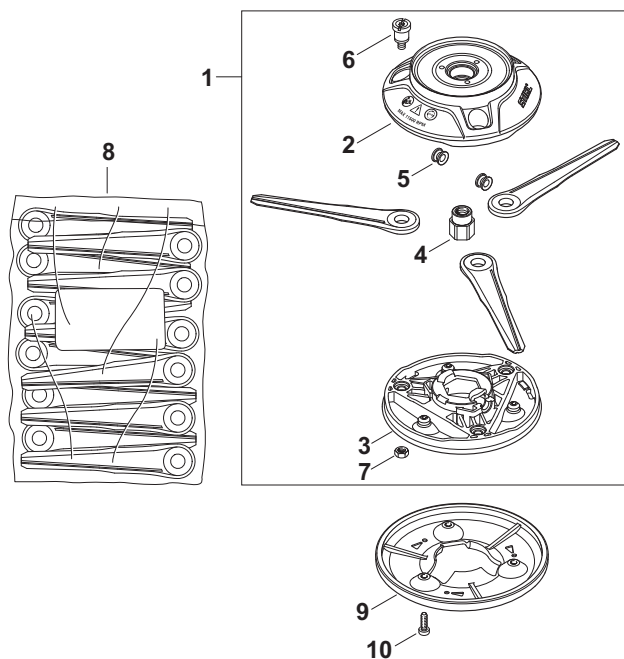

Nr.	Delnummer	Mængde	Betegnelse
1	4002 710 2176	1	Trimmerhoved PolyCut 27-3 □ 2 - 7
2	4002 713 9611	1	Overdel
3	4002 710 9700	1	Underdel
4	4002 713 6801	1	Kravemøtrik M10x1 venstre side
5	4002 713 8300	2	Hylse
6	4111 710 8700	3	Kraveskrue
7	9210 319 0900	3	Møtrik DIN934-M6-10
8	4002 007 1000	1	Sæt med knive (12 stk.)
9	4003 007 1000	1	Sæt, beskyttelsesskærm ? 10
10	9074 477 4130	3	Skrue IS-P5x16

PolyCut 40-3

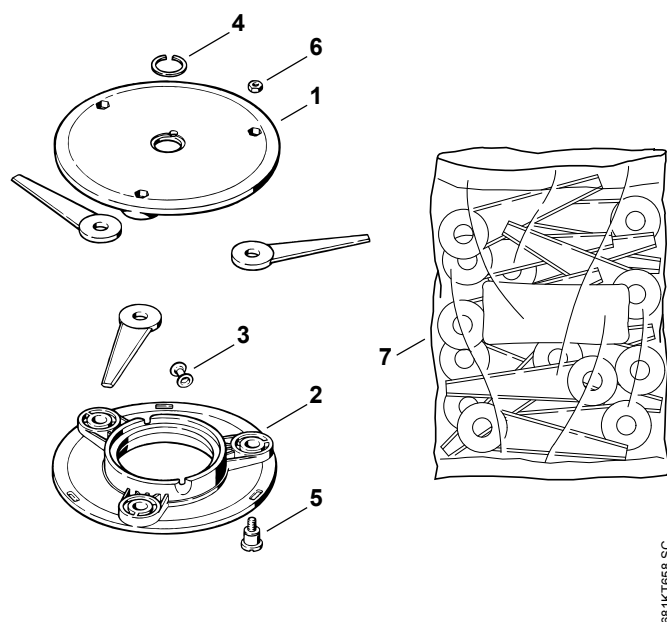

Nr.	Delnummer	Mængde	Betegnelse
	4111 710 2100	1	Trimmerhoved PolyCut 40-3 (C) □ 1 - 7
1	4111 713 9601	1	Overdel
2	4111 713 9701	1	Underdel
3	4002 713 8300	2	Hylse
4	4111 716 9300	1	Ring
5	4111 710 8700	3	Kraveskrue
6	9210 319 0900	3	Møtrik DIN934-M6-10
7	4111 007 1001	1	Sæt med knive (12 stk.)

PolyCut 41-3

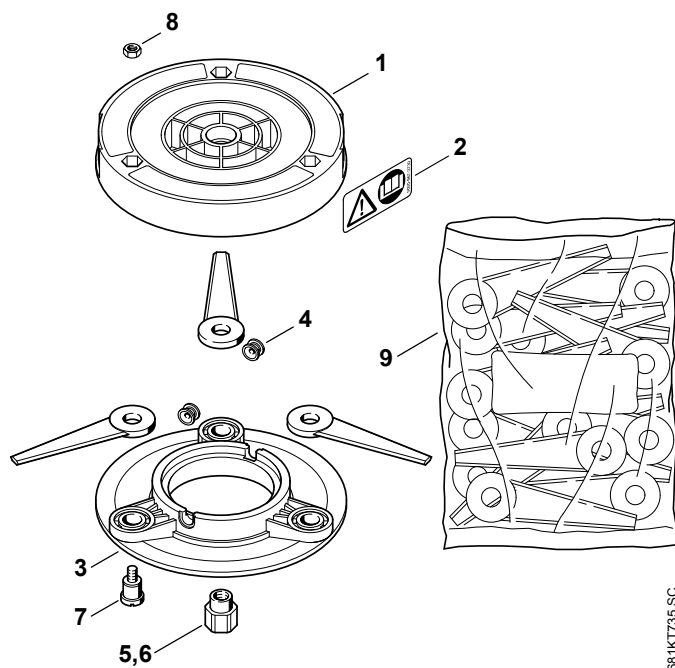

Nr.	Delnummer	Mængde	Betegnelse
	4003 710 2113	1	Trimmerhoved PolyCut 41-3 □ 1 - 9
1	4003 713 9602	1	Overdel
2	0000 967 3730	1	Advarselshenvisning, piktogrammer
3	4111 713 9701	1	Underdel
4	4002 713 8300	2	Hylse
5	4003 713 6801	1	Kravemøtrik M12x1,5 venstre side
6	4005 713 6800	1	Kravemøtrik M14x1,5 venstre side
7	4111 710 8700	3	Kraveskrue
8	9210 319 0900	3	Møtrik DIN934-M6-10
9	4111 007 1001	1	Sæt med knive (12 stk.)

PolyCut 47-3

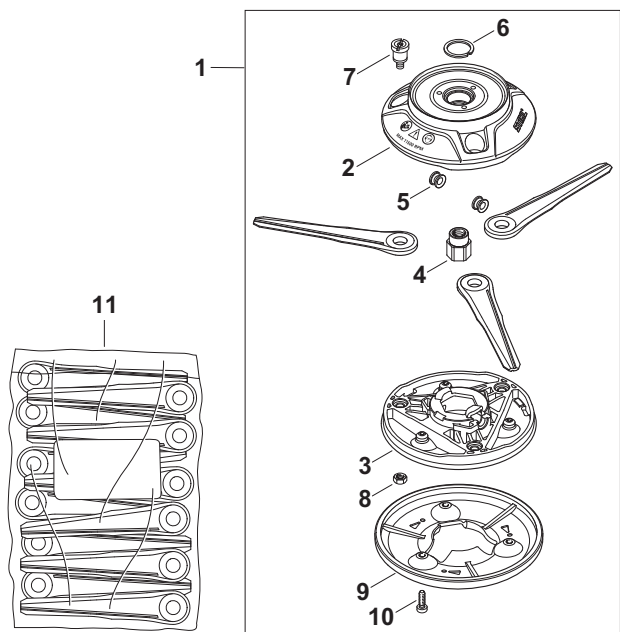

0000-GXX-6609-A0

Nr.	Delnummer	Mængde	Betegnelse
1	4003 710 2117	1	Trimmerhoved PolyCut 47-3 ? 2 -10
2	4003 713 9606	1	Overdel
3	4002 710 9700	1	Underdel
4	4003 713 6801	1	Kravemøtrik M12x1,5 venstre side
5	4002 713 8300	2	Hylse
6	4111 716 9300	1	Ring
7	4111 710 8700	3	Kraveskrue
8	9210 319 0900	3	Møtrik DIN934-M6-10
9	4003 007 1000	1	Sæt, beskyttelsesskærm ? 10
10	9074 477 4130	3	Skrue IS-P5x16
11	4002 007 1000	1	Sæt med knive (12 stk.)

DuroCut 5-2

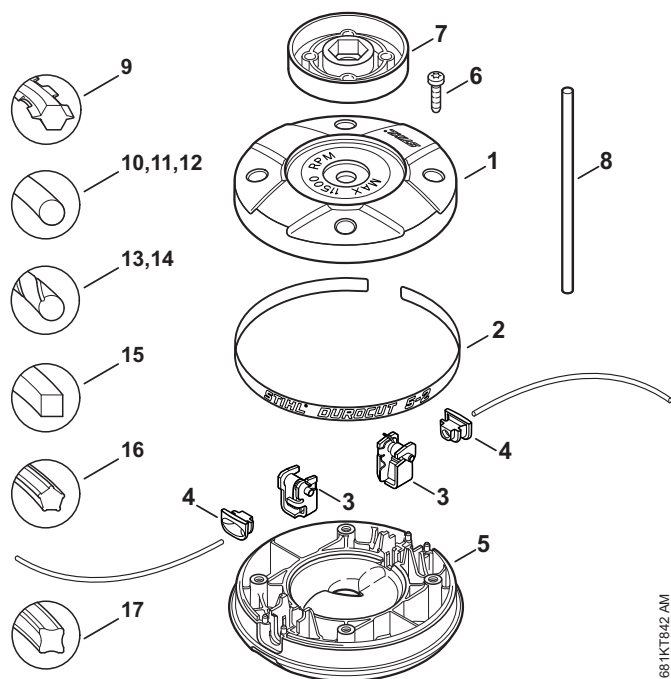

Nr.	Delnummer	Mængde	Betegnelse
	4006 710 2131	1	Trimmerhoved DuroCut 5-2
			□ 1 - 9
	4006 710 2125	1	Trimmerhoved DuroCut 5-2 (C)
1	4006 710 9600	1	Overdel
2	4006 967 4604	1	Hensvisningsskilt
3	4002 710 4500	2	Holder
4	4006 713 8301	2	Hylse
5	4006 713 9702	1	Underdel
6	9074 477 4135	4	Skrue IS-P5x20
7	4140 713 1501	1	Trykskive
8	4130 893 7800	1	Stikdorn
9	0000 930 3503	2	Fortandet trimmertråd Ø 2 x 195 mm 48 stk.
10		2	Rund trimmertråd Ø 1,6 x 195 m (B)
	0000 930 2334	1	Rund trimmertråd Ø 1,6 mm x 19 m (A,B)
11		2	Rund trimmertråd Ø 2 x 195 mm (B)
	0000 930 2335	1	Rund trimmertråd Ø 2mm x 14 m (A,B)
12		2	Rund trimmertråd Ø 2,4 x 195 m (B)
	0000 930 2338	1	Rund trimmertråd Ø 2,4 mm x 14 m (A,B)
13		2	Rund trimmertråd, støjsvag Ø 2 x 185 mm (B)
	0000 930 2416	1	Rund trimmertråd, støjsvag Ø 2 mm x 14 m (A,B)
14		2	Rund trimmertråd, støjsvag Ø 2,4 x 195 mm (B)
	0000 930 2419	1	Rund trimmertråd, støjsvag Ø 2,4 mm x 14 m (A,B)
15		2	Kvadratisk trimmertråde Ø 2,4 x 195 mm (B)
	0000 930 2640	1	Kvadratisk trimmertråd Ø 2,4 mm x 41 m (A,B)
16		2	5-kantet trimmertråd Ø 2,4 x 195 mm (B)
	0000 930 3340	1	5-kantet trimmertråd Ø 2,4 mm x 48 m (A,B)
17		2	X-formet trimmertråd Ø 2,4 x 195 mm (B)
	0000 930 3410	1	X-formet trimmertråd Ø 2,4 mm x 83 m (A,B) USA

DuroCut 20-2

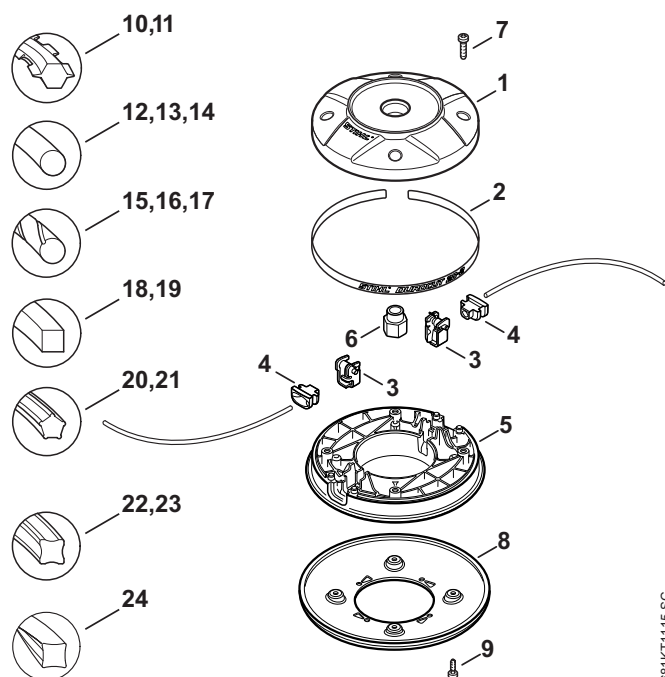

681KT115 SC

Nr.	Delnummer	Mængde	Betegnelse
	4002 710 2182	1	Trimmerhoved DuroCut 20-2
			□ 1 - 7, 11
	4002 710 2167	1	Trimmerhoved DuroCut 20-2 (C)
1	4002 713 9607	1	Overdel
2	4002 967 4618	1	Hensvisningsskilt
3	4002 710 4500	2	Holder
4	4002 713 8304	2	Hylse
5	4002 713 9703	2	Underdel
6	4002 713 6801	1	Kravemøtrik M10x1 venstre side
7	9074 477 4135	4	Skrue IS-P5x20
	4005 007 1001	1	Sæt med beskyttelse (B)
			□ 8, 9
8	4005 713 4500	1	Beskyttelse (B)
9	9074 478 3005	4	Skrue IS-P4x14 (B)
10	0000 930 3503	2	Fortandet trimmertråd Ø 2 x 195 mm (B) 48 stk.
11	0000 930 3504	2	Fortandet trimmertråd Ø 3 x 185 mm 48 stk.
12	0000 930 2335	1	Rund trimmertråd Ø 2 mm x 14 m (B)
13	0000 930 2338	1	Rund trimmertråd Ø 2,4 mm x 14 m (B)
14	0000 930 2341	1	Rund trimmertråd Ø 2,7 mm x 9 m (B)
15	0000 930 2416	1	Rund trimmertråd, støjsvag Ø 2 mm x 14 m (B)
16	0000 930 2419	1	Rund trimmertråd, støjsvag Ø 2,4 mm x 14 m (B)
17	0000 930 2422	1	Rund trimmertråd, støjsvag Ø 2,7 mm x 9 m (B)
18	0000 930 2640	1	Kvadratisk trimmertråd Ø 2,4 mm x 41 m (B)
19	0000 930 2642	1	Kvadratisk trimmertråd Ø 2,7 mm x 32 m (B)
20	0000 930 3340	1	5-kantet trimmertråd Ø 2,4 mm x 48 m (B)
21	0000 930 3343	1	5-kantet trimmertråd Ø 2,7 mm x 77 m (B)
22	0000 930 3410	1	X-formet trimmertråd Ø 2,4 mm x 83 m (B) USA
23	0000 930 3411	1	X-formet trimmertråd Ø 2,7 mm x 65 m (B) USA
24	0000 930 4301	1	Trimmertråd CF3 Pro Ø 2,7 mm x 26 m 3K (B)

DuroCut 40-4

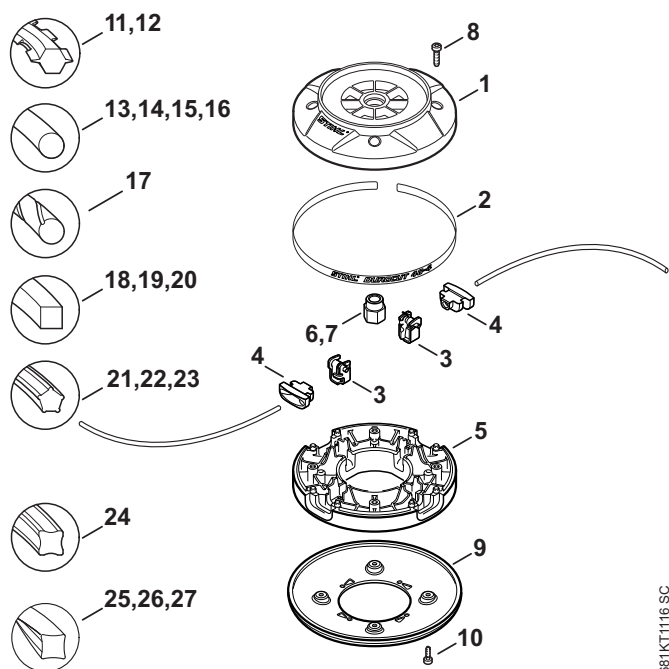

681KT116 SC

Nr.	Delnummer	Mængde	Betegnelse
	4005 710 2114	1	Trimmerhoved DuroCut 40-4
			□ 1 - 10, 12
	4005 710 2106	1	Trimmerhoved DuroCut 40-4 (C)
1	4003 713 9603	1	Overdel
2	4005 967 4604	1	Henvisningsskilt
3	4005 710 4500	4	Holder
4	4005 713 8301	4	Hylse
5	4005 713 9700	1	Underdel
6	4003 713 6801	1	Kravemøtrik M12x1,5 venstre side
7	4005 713 6800	1	Kravemøtrik M14x1,5 venstre side
8	9074 477 4135	4	Skrue IS-P5x20
9	4005 713 4500	1	Beskyttelsesskærm
10	9074 478 2970	4	Skrue IS-P4x10
11	0000 930 3504	4	Fortandet trimmertråd Ø 3 x 185 mm (B) 48 stk.
12	0000 930 3505	4	Fortandet trimmertråd Ø 4 x 215 mm 48 stk.
13	0000 930 2341	1	Rund trimmertråd Ø 2,7 mm x 9 m (B)
14	0000 930 2344	1	Rund trimmertråd Ø 3 mm x 53 m (B)
15	0000 930 2345	1	Rund trimmertråd Ø 3,3 mm x 6 m (B)
16	0000 930 3605	4	Rund trimmertråd Ø 4 x 215 mm (B) 48 stk.
17	0000 930 3708		Rund trimmertråd, støjsvag Ø 4 mm x 27 m (B)
18	0000 930 2642	1	Kvadratisk trimmertråd Ø 2,7 mm x 32 m (B)
19	0000 930 2644	1	Kvadratisk trimmertråd Ø 3 mm x 53 m (B)
20	0000 930 2645	1	Kvadratisk trimmertråd Ø 3,3 mm x 38 m (B)
21	0000 930 3343	1	5-kantet trimmertråd Ø 2,7 mm x 77 m (B)
22	0000 930 3344	1	5-kantet trimmertråd Ø 3 mm x 58 m (B)
23	0000 930 3345	1	5-kantet trimmertråd Ø 3,3 mm x 23 m (B)
24	0000 930 3411	1	X-formet trimmertråd Ø 2,7 mm x 65 m (B) USA
25	0000 930 4301	1	Trimmertråd CF3 Pro Ø 2,7 mm x 26 m 3K (B)
26	0000 930 4302	1	Trimmertråd CF3 Pro Ø 3,0 mm x 21 m 3K (B)
27	0000 930 4311	1	Trimmertråd CF3 Pro Ø 3,3 mm x 34 m 3K (B)

FixCut 5-2

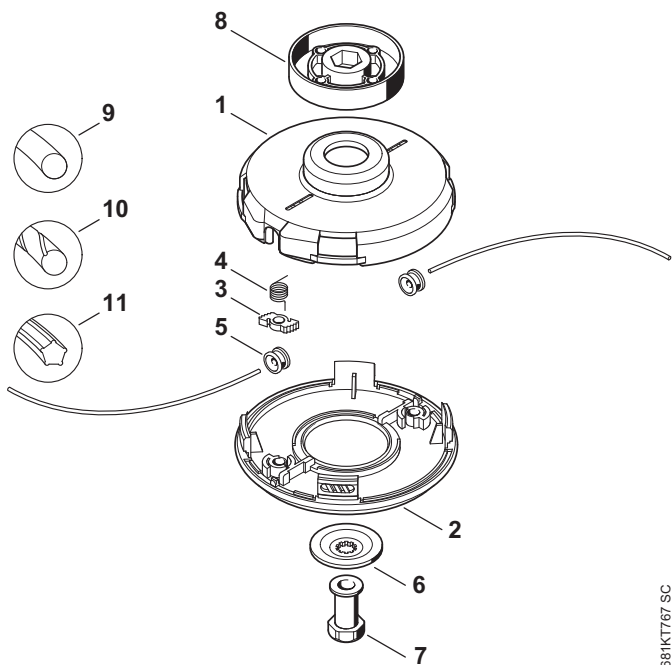

681KT767 SC

Nr.	Delnummer	Mængde	Betegnelse
	4006 710 2117	1	Trimmerhoved FixCut 5-2
			□ 2 - 8, 10
1		1	Overdel (D)
2	4002 713 9702	1	Underdel
3	4001 713 7200	2	Klinke
4	4001 998 0400	2	Torsionsfjeder
5	4001 713 8300	2	Hylse
6	4130 713 1600	1	Trykskive
7	4006 713 6801	1	Kravemøtrik M8
8	4140 713 1501	1	Trykskive
9		2	Rund trimmertråd Ø 2,4 x 203 mm (D)
	0000 930 2310	1	Rund trimmertråd Ø 2,4 x 203 mm (A,B) 50 stk.
10			Rund trimmertråd, støjsvag Ø 2,4 x 203 mm (D)
	0000 930 2419	1	Rund trimmertråd, støjsvag Ø 2,4 mm x 14 m (A,B)
11	0000 930 3340	1	5-kantet trimmertråd Ø 2,4 mm x 48 m (B)

FixCut 25-2

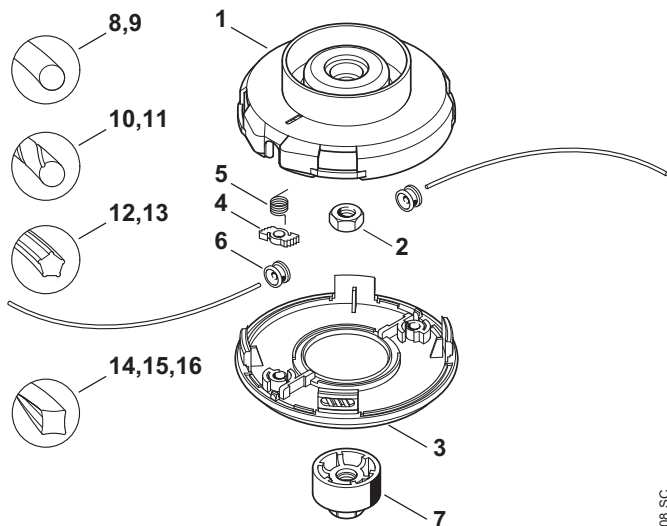

Nr.	Delnummer	Mængde	Betegnelse
	4006 710 2157	1	Trimmerhoved FixCut 5-2
			□ 1 - 6, 10
1		1	Overdel (D)
2	9211 260 1350	1	Møtrik DIN936-M10x1LH-05
3	4002 713 9702	1	Underdel
4	4001 713 7200	2	Klinke
5	4001 998 0400	2	Torsionsfjeder
6	4001 713 8300	2	Hylse
7	4001 710 9400	1	Trykstykke USA, CDN
8		2	Rund trimmertråd Ø 2,4 x 203 mm (D)
	0000 930 2310	1	Rund trimmertråd Ø 2,4 x 203 mm (A,B) 50 stk.
9	0000 930 2312	1	Rund trimmertråd Ø 3,3 x 203 mm (B) 50 stk. USA, CDN
10		1	Rund trimmertråd, støjsvag Ø 2,4 x 203 mm (D)
	0000 930 2419	1	Rund trimmertråd, støjsvag Ø 2,4 mm x 14 m (A,B)
11	0000 930 2422	1	Rund trimmertråd, støjsvag Ø 2,7 mm x 9 m (A,B)
12	0000 930 3340	1	5-kantet trimmertråd Ø 2,4 mm x 48 m (B)
13	0000 930 3344	1	5-kantet trimmertråd Ø 3 mm x 58 m (B)
14	0000 930 4301	1	Trimmertråd CF3 Pro Ø 2,7 mm x 26 m 3K (B)
15	0000 930 4302	1	Trimmertråd CF3 Pro Ø 3,0 mm x 21 m 3K (B)
16	0000 930 4311	1	Trimmertråd CF3 Pro Ø 3,3 mm x 34 m 3K (B)

FixCut 31-2

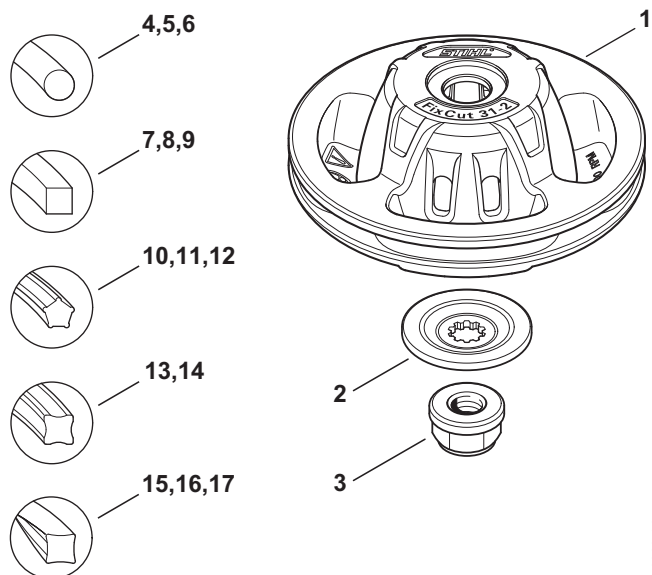

Nr.	Delnummer	Mængde	Betegnelse
	4006 710 2157	1	Trimmerhoved FixCut 5-2 □ 1 - 3
1	4001 710 2105	1	Trimmerhoved FixCut 31-2
2	4130 713 1600	1	Trykskive
3	4126 642 7600	1	Krave-sikringsmøtrik M10x1 venstre side
4	0000 930 2338	1	Rund trimmertråd Ø 2,4 mm x 14 m (B)
5	0000 930 2341	1	Rund trimmertråd Ø 2,7 mm x 9 m (B)
6	0000 930 2345	1	Rund trimmertråd Ø 3,3 mm x 6 m (B)
7	0000 930 2601	1	Kvadratisk trimmertråd Ø 2,4 mm x 253 m mørkegrøn (B)
8	0000 930 2626	1	Kvadratisk trimmertråd Ø 2,7 mm x 208 m mørkegrøn (B)
9	0000 930 2645	1	Kvadratisk trimmertråd Ø 3,3 mm x 38 m (B)
10	0000 930 3340	1	5-kantet trimmertråd Ø 2,4 mm x 48 m
11	0000 930 3342	1	5-kantet trimmertråd Ø 2,7 mm x 38 m (B)
12	0000 930 3345	1	5-kantet trimmertråd Ø 3,3 mm x 24 m (B)
13	0000 930 3410	1	X-formet trimmertråd Ø 2,4 mm x 86 m (B)
14	0000 930 3404	1	X-formet trimmertråd Ø 2,7 mm x 222 m (B)
15	0000 930 4300	1	Trimmertråd CF3 Pro Ø 2,4 mm x 35 m 3K (B)
16	0000 930 4301	1	Trimmertråd CF3 Pro Ø 2,7 mm x 26 m 3K (B)
17	0000 930 4311	1	Trimmertråd CF3 Pro Ø 3,3 mm x 36,0 m 3K (B)

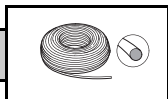

Runde trimmertråde

Mål	Farve	Delnummer	Betegnelse
Ø 1,4 mm	Transparent		
16 m		0000 930 2284	Rund trimmertråd Ø 1,4 mm x 16 m
Ø 1,6 mm	Blå		
19 m		0000 930 2334	Rund trimmertråd Ø 1,6 mm x 19 m
Ø 2,0 mm	Grøn		
14 m		0000 930 2335	Rund trimmertråd Ø 2 mm x 14 m
60 m		0000 930 2336	Rund trimmertråd Ø 2 mm x 60 m
119 m		0000 930 2337	Rund trimmertråd Ø 2 mm x 119 m
360 m		0000 930 2263	Rund trimmertråd Ø 2 mm x 360 m
601 m		0000 930 2264	Rund trimmertråd Ø 2 mm x 601 m
1503 m		0000 930 2575	Rund trimmertråd Ø 2 mm x 1503 m
Ø 2,4 mm	Orange		
14 m		0000 930 2338	Rund trimmertråd Ø 2,4 mm x 14 m
41 m		0000 930 2339	Rund trimmertråd Ø 2,4 mm x 41 m
83 m		0000 930 2340	Rund trimmertråd Ø 2,4 mm x 83 m
253 m		0000 930 2246	Rund trimmertråd Ø 2,4 mm x 253 m
420 m		0000 930 2247	Rund trimmertråd Ø 2,4 mm x 420 m
1053 m		0000 930 2573	Rund trimmertråd Ø 2,4 mm x 1053 m
Ø 2,7 mm	Rød		
9 m		0000 930 2341	Rund trimmertråd Ø 2,7 mm x 9 m
32 m		0000 930 2342	Rund trimmertråd Ø 2,7 mm x 32 m
65 m		0000 930 2343	Rund trimmertråd Ø 2,7 mm x 65 m
208 m		0000 930 2227	Rund trimmertråd Ø 2,7 mm x 208 m
347 m		0000 930 2289	Rund trimmertråd Ø 2,7 mm x 347 m
869 m		0000 930 2571	Rund trimmertråd Ø 2,7 mm x 869 m

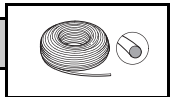

Runde trimmertråde

Mål	Farve	Delnummer	Betegnelse
Ø 3,0 mm	Gul		
53 m		0000 930 2344	Rund trimmertråd Ø 3 mm x 53 m
162 m		0000 930 2542	Rund trimmertråd Ø 3 mm x 162 m
271 m		0000 930 2543	Rund trimmertråd Ø 3 mm x 271 m
Ø 3,3 mm	Sort		
6 m		0000 930 2345	Rund trimmertråd Ø 3,3 mm x 6 m
19 m		0000 930 2346	Rund trimmertråd Ø 3,3 mm x 19 m
38 m		0000 930 2347	Rund trimmertråd Ø 3,3 mm x 38 m
137 m		0000 930 2287	Rund trimmertråd Ø 3,3 mm x 137 m
228 m		0000 930 2290	Rund trimmertråd Ø 3,3 mm x 228 m
573 m		0000 930 2569	Rund trimmertråd Ø 3,3 mm x 573 m
Ø 4,0 mm	Mørkegrøn		
27 m		0000 930 3607	Rund trimmertråd Ø 4 mm x 27 m

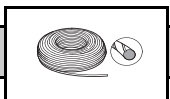

Runde trimmertråde, støjsvage

Mål	Farve	Delnummer	Betegnelse
Ø 1,6 mm	Blå		
19 m		0000 930 2415	Rund trimmertråd, støjsvag Ø 1,6 mm x 19 m
Ø 2,0 mm	Grøn		
14 m		0000 930 2416	Rund trimmertråd, støjsvag Ø 2 mm x 14 m
60 m		0000 930 2418	Rund trimmertråd, støjsvag Ø 2 mm x 60 m
119 m		0000 930 2424	Rund trimmertråd, støjsvag Ø 2 mm x 119 m
Ø 2,4 mm	Orange		
14 m		0000 930 2419	Rund trimmertråd, støjsvag, Ø 2,4 mm x 14 m
41 m		0000 930 2420	Rund trimmertråd, støjsvag Ø 2,4 mm x 41 m
83 m		0000 930 2421	Rund trimmertråd, støjsvag Ø 2,4 mm x 83 m
253 m		0000 930 2535	Rund trimmertråd, støjsvag Ø 2,4 mm x 253 m
Ø 2,7 mm	Rød		
9 m		0000 930 2422	Rund trimmertråd, støjsvag, Ø 2,7 mm x 9 m
65 m		0000 930 2423	Rund trimmertråd, støjsvag Ø 2,7 mm x 65 m

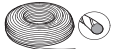

Runde trimmertråde, støjsvage

Mål	Farve	Delnummer	Betegnelse
Ø 4 mm	Mørkegrøn		
27 m		0000 930 3708	Rund trimmertråd, støjsvag Ø 4 mm x 27 m

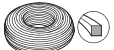

Kvadratiske trimmertråde

Mål	Farve	Delnummer	Betegnelse
Ø 2,4 mm	Orange		
41 m		0000 930 2640	Kvadratisk trimmertråd Ø 2,4 mm x 41 m
83 m		0000 930 2641	Kvadratisk trimmertråd Ø 2,4 mm x 83 m
253 m		0000 930 2612	Kvadratisk trimmertråd Ø 2,4 mm x 253 m
420 m		0000 930 2613	Kvadratisk trimmertråd Ø 2,4 mm x 420 m
Ø 2,7 mm	Rød		
32 m		0000 930 2642	Kvadratisk trimmertråd Ø 2,7 mm x 32 m
65 m		0000 930 2643	Kvadratisk trimmertråd Ø 2,7 mm x 65 m
208 m		0000 930 2616	Kvadratisk trimmertråd Ø 2,7 mm x 208 m
347 m		0000 930 2617	Kvadratisk trimmertråd Ø 2,7 mm x 347 m
Ø 3,0 mm	Gul		
53 m		0000 930 2644	Kvadratisk trimmertråd Ø 3 mm x 53 m
162 m		0000 930 2619	Kvadratisk trimmertråd Ø 3 mm x 162 m
271 m		0000 930 2620	Kvadratisk trimmertråd Ø 3 mm x 271 m

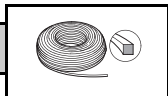

Kvadratiske trimmertråde

Mål	Farve	Delnummer	Betegnelse
Ø 3,3 mm	Sort		
38 m		0000 930 2645	Kvadratisk trimmertråd Ø 3,3 mm x 38 m
137 m		0000 930 2622	Kvadratisk trimmertråd Ø 3,3 mm x 137 m
228 m		0000 930 2623	Kvadratisk trimmertråd Ø 3,3 mm x 228 m
Ø 4,0 mm	Sort		
28 m		0000 930 3611	Kvadratisk trimmertråd Ø 4 mm x 28 m

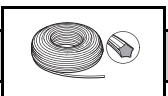

Femkantede trimmertråde

Mål	Farve	Delnummer	Betegnelse
Ø 2,4 mm	Orange		
48 m		0000 930 3340	5-kantet trimmertråd Ø 2,4 mm x 48 m
97 m		0000 930 3341	5-kantet trimmertråd Ø 2,4 mm x 97 m
291 m		0000 930 3339	5-kantet trimmertråd Ø 2,4 mm x 291 m
Ø 2,7 mm	Rød		
38 m		0000 930 3342	5-kantet trimmertråd Ø 2,7 mm x 38 m
77 m		0000 930 3343	5-kantet trimmertråd Ø 2,7 mm x 77 m
215 m		0000 930 3303	5-kantet trimmertråd Ø 2,7 mm x 215 m
Ø 3,0 mm	Gul		
58 m		0000 930 3344	5-kantet trimmertråd Ø 3 mm x 58 m
203 m		0000 930 3305	5-kantet trimmertråd Ø 3 mm x 203 m
339 m		0000 930 3306	5-kantet trimmertråd Ø 3 mm x 339 m
Ø 3,3 mm	Sort		
23 m		0000 930 3345	5-kantet trimmertråd Ø 3,3 mm x 23 m
46 m		0000 930 3346	5-kantet trimmertråd Ø 3,3 mm x 46 m

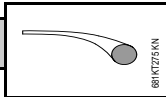

Runde trimmertråde, tilpasset længde

Mål	Farve	Delnummer	Betegnelse
Ø 2,4 mm	Orange		
50 m		0000 930 2315	Rund trimmertråd Ø 2,4 x 203 mm
100 m		0000 930 2317	Rund trimmertråd Ø 2,4 x 203 mm
Ø 3,3 mm	Sort		
50 m		0000 930 2312	Rund trimmertråd Ø 3,3 x 203 mm
100 m		0000 930 2313	Rund trimmertråd Ø 3,3 x 203 mm
Ø 4,0 mm	Mørkegrøn		
48 m		0000 930 3605	Rund trimmertråd Ø 4 x 215 mm

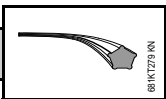

Femkantede trimmertråde, afkortet

Mål	Farve	Delnummer	Betegnelse
Ø 2,4 mm	Orange		
50 m		0000 930 3316	5-kantet trimmertråd Ø 2,4 x 203 mm
100 m		0000 930 3317	5-kantet trimmertråd Ø 2,4 x 203 mm
Ø 3,3 mm	Gul		
50 m		0000 930 3318	5-kantet trimmertråd Ø 3 x 203 mm
100 m		0000 930 3319	5-kantet trimmertråd Ø 3 x 203 mm

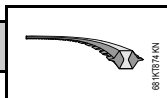

Fortandet trimmertråd, tilpasset længde

Mål	Farve	Delnummer	Betegnelse
Ø 2,0 mm	Bronze		
48 m		0000 930 3503	Fortandet trimmertråd Ø 2 x 195 mm
Ø 3,0 mm	Sølv		
48 m		0000 930 3504	Fortandet trimmertråd Ø 3 x 185 mm
Ø 4,0 mm	Guld		
48 m		0000 930 3505	Fortandet trimmertråd Ø 4 x 215 mm

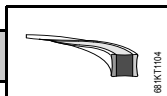

Trimmertråde CF3 Pro

Mål	Farve	Delnummer	Betegnelse
Ø 2,4 mm	Flerfarvet		
35 m		0000 930 4300	Trimmertråd CF3 Pro Ø 2,4 mm x 35 m 3K
70 m		0000 930 4303	Trimmertråd CF3 Pro Ø 2,4 mm x 70 m 3K
212 m		0000 930 4313	Trimmertråd CF3 Pro Ø 2,4 mm x 212,0 m 3K
Ø 2,7 mm	Flerfarvet		
27 m		0000 930 4301	Trimmertråd CF3 Pro Ø 2,7 mm x 26 m 3K
55 m		0000 930 4304	Trimmertråd CF3 Pro Ø 2,7 mm x 53 m 3K
172 m		0000 930 4314	Trimmertråd CF3 Pro Ø 2,7 mm x 172,0 m 3K
Ø 3,0 mm	Flerfarvet		
22 m		0000 930 4302	Trimmertråd CF3 Pro Ø 3,0 mm x 21 m 3K
45 m		0000 930 4305	Trimmertråd CF3 Pro Ø 3,0 mm x 43 m 3K
134 m		0000 930 4315	Trimmertråd CF3 Pro Ø 3,0 mm x 134,0 m 3K
Ø 3,3 mm	Flerfarvet		
36 m		0000 930 4311	Trimmertråd CF3 Pro Ø 3,3 mm x 34 m 3K
113 m		0000 930 4316	Trimmertråd CF3 Pro Ø 3,3 mm x 113,0 m 3K

Afbalanceringsapparat, slibevejledninger og slibeværktøjer

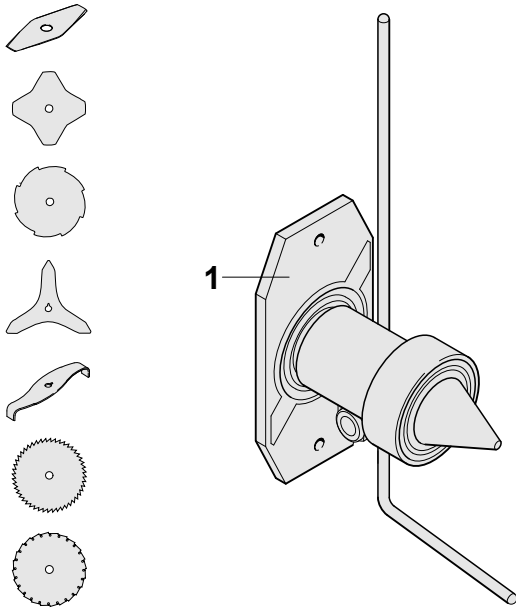

681KT938 KN

Nr.	Delnummer	Mængde	Betegnelse
1	5910 850 2600	1	Afbalanceringsapparat (B)

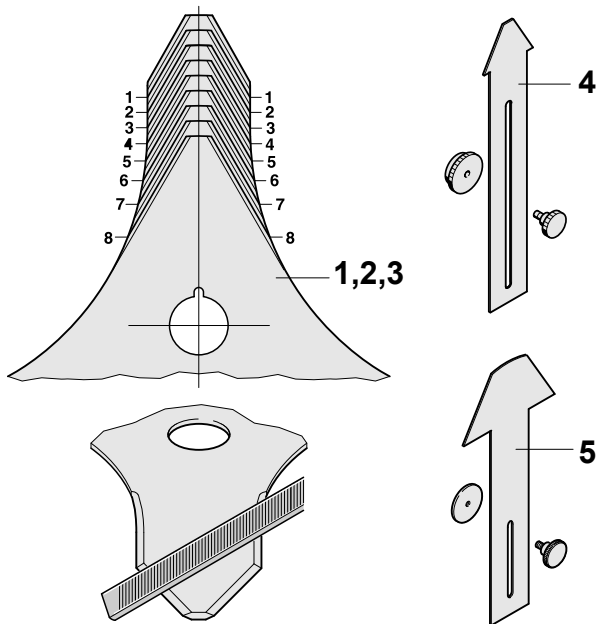

681KT937 KN

Nr.	Delnummer	Mængde	Betegnelse
1	0457 342 2629	1	Slibevejledning til kratkniv 250-3 (B)
2	0457 342 2631	1	Slibevejledning til kratkniv 300-3 (B)
3	0457 342 2636	1	Slibevejledning til kratkniv 350-3 (B)
4	4020 890 5500	1	Slibeskabelon 250-3, 300-3, 350-3 (B)
5	4020 890 5501	1	Slibeskabelon 305-2 (B)

Afbalanceringsapparat, slibevejledninger og slibeværktøjer

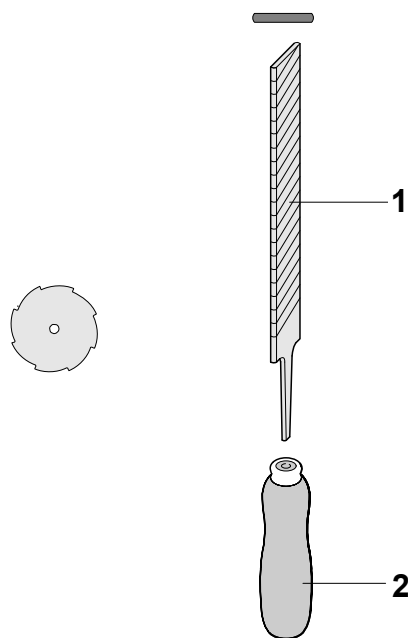

681KT942 KN

Nr.	Delnummer	Mængde	Betegnelse
1	0814 212 3310	1	Fladfil DIN7272-F 200-3
1	0814 212 3000	1	Fladfil DIN7272-F 200-3 med etui
2	0711 490 7860	1	Filgreb A100

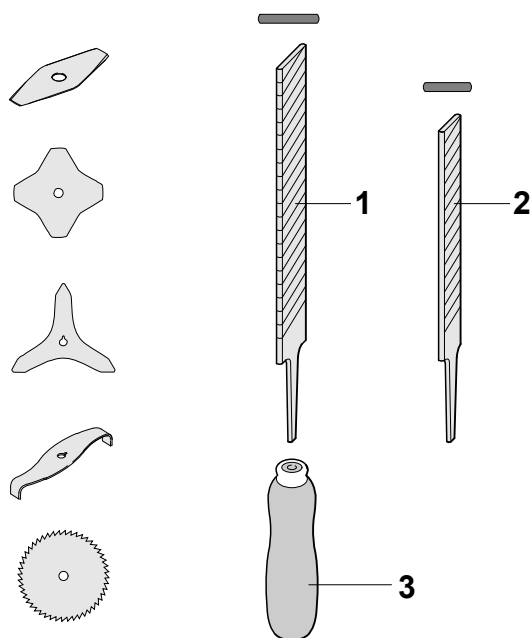

681KT939 KN

Nr.	Delnummer	Mængde	Betegnelse
1	0814 252 3356	1	Fladfil 150x16x2,7
2	0814 212 3310	1	Fladfil DIN7272-F200-3
2	0814 212 3000	1	Fladfil DIN7272-F 200-3 med etui
3	0811 490 7860	1	Filgreb A100

Afbalanceringsapparat, slibevejledninger og slibeværktøjer

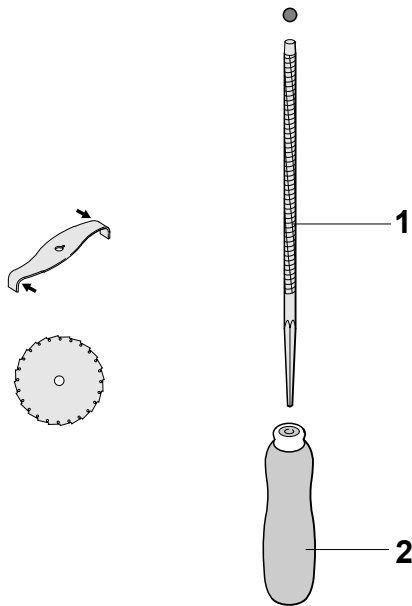

681KT940 KN

Nr.	Delnummer	Mængde	Betegnelse
1	5605 772 5506	1	Rundfil Ø 5,5 x 200 mm
2	0811 490 7860		Filgreb A100

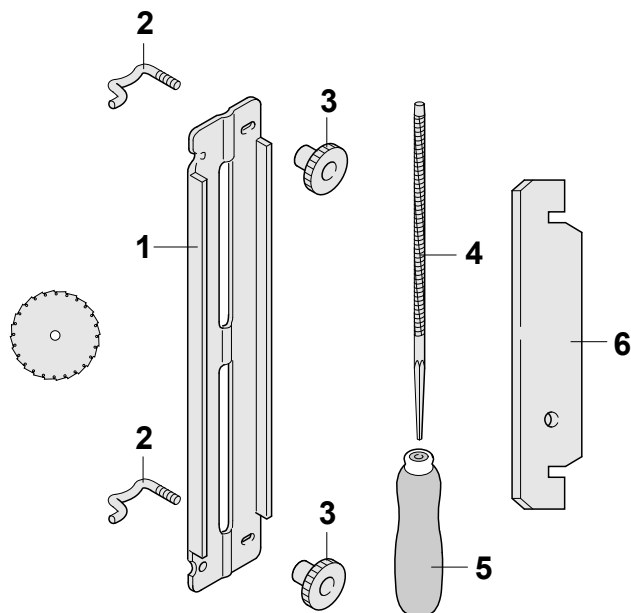

681KT941 KN

Nr.	Delnummer	Mængde	Betegnelse
1	5605 750 4343	1	Fileholder Rundsavsklinge Mejseltandet □ 2 - 5
2	5605 752 8300	1	Bøjle
3	5605 752 7700	1	Møtrik
4	5605 772 5506	1	Rundfil Ø 5,5 x 200 mm
5	0811 490 7860	1	Filgreb A100
6	4020 893 5000		Skrængejern

Afbalanceringsapparat, slibevejledninger og slibeværktøjer

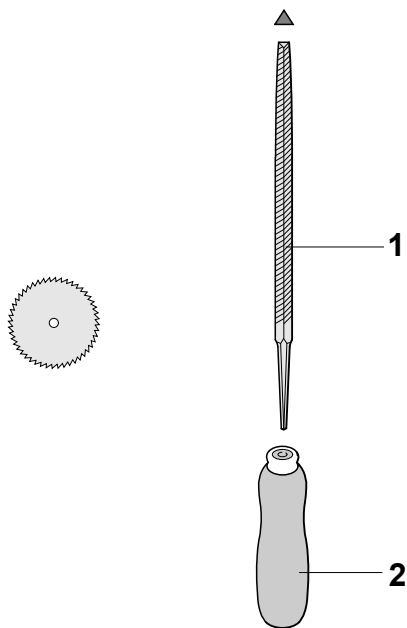

681KT943 KN

Nr.	Delnummer	Mængde	Betegnelse
1	0811 421 8971	1	Trekantfil
2	0811 490 7860	1	Filgreb A100

Transportbeskyttelse til skæreværktøj af metal

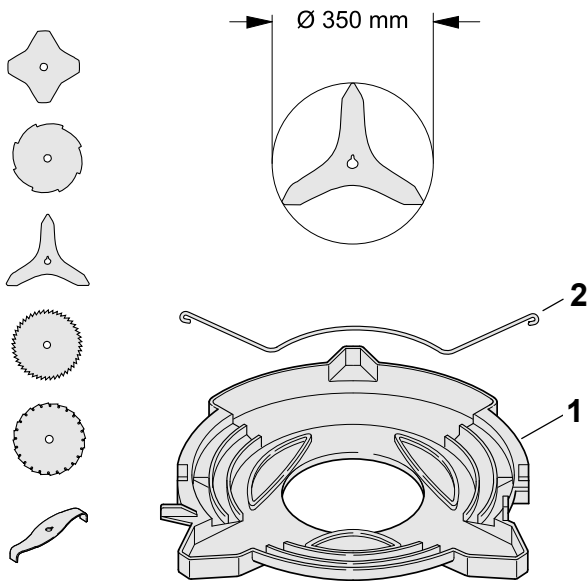

681KT1100 KN

Nr.	Delnummer	Mængde	Betegnelse
1	4116 790 3901	1	Transportbeskyttelse Ø 350 □ 2
2	4116 792 4300	1	Spændebøjle

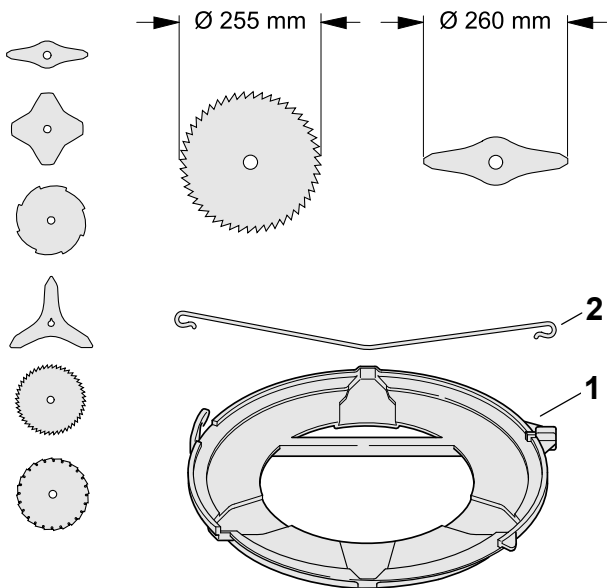

681KT709 KN

Nr.	Delnummer	Mængde	Betegnelse
1	4119 790 3906	1	Transportbeskyttelse Ø 260 □ 2
2	4119 792 4305	1	Spændebøjle

Transportbeskyttelse til skæreværktøj af metal

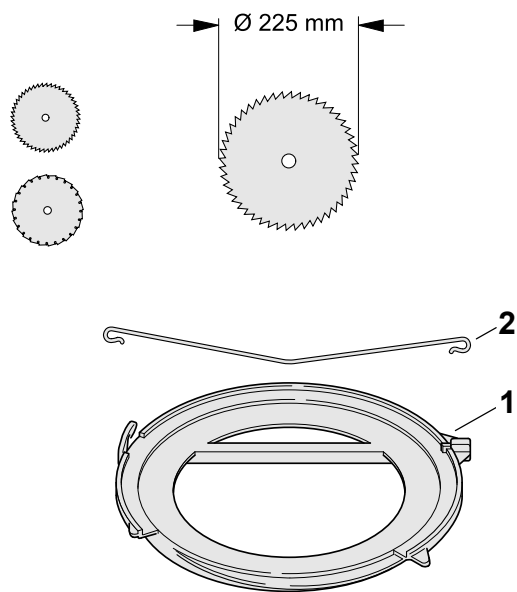

681KT702 KN

Nr.	Delnummer	Mængde	Betegnelse
1	4119 790 3901	1	Transportbeskyttelse Ø 225 □ 2
2	4119 792 4300	1	Spændebøjle

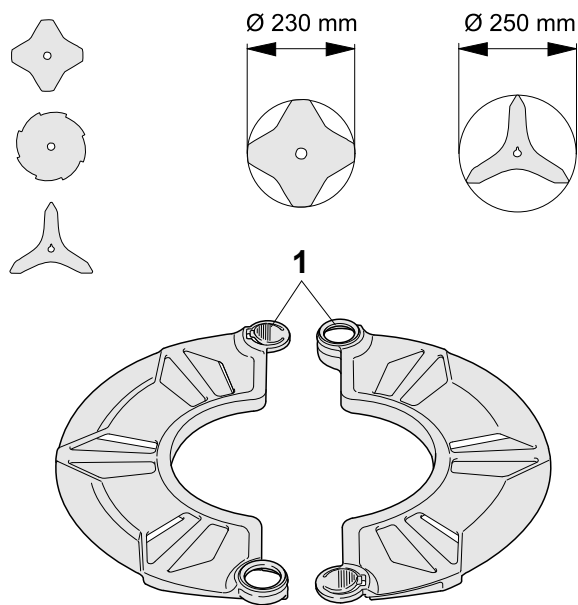



681KT982 KN

Nr.	Delnummer	Mængde	Betegnelse
1	0000 790 3901	1	Transportbeskyttelse

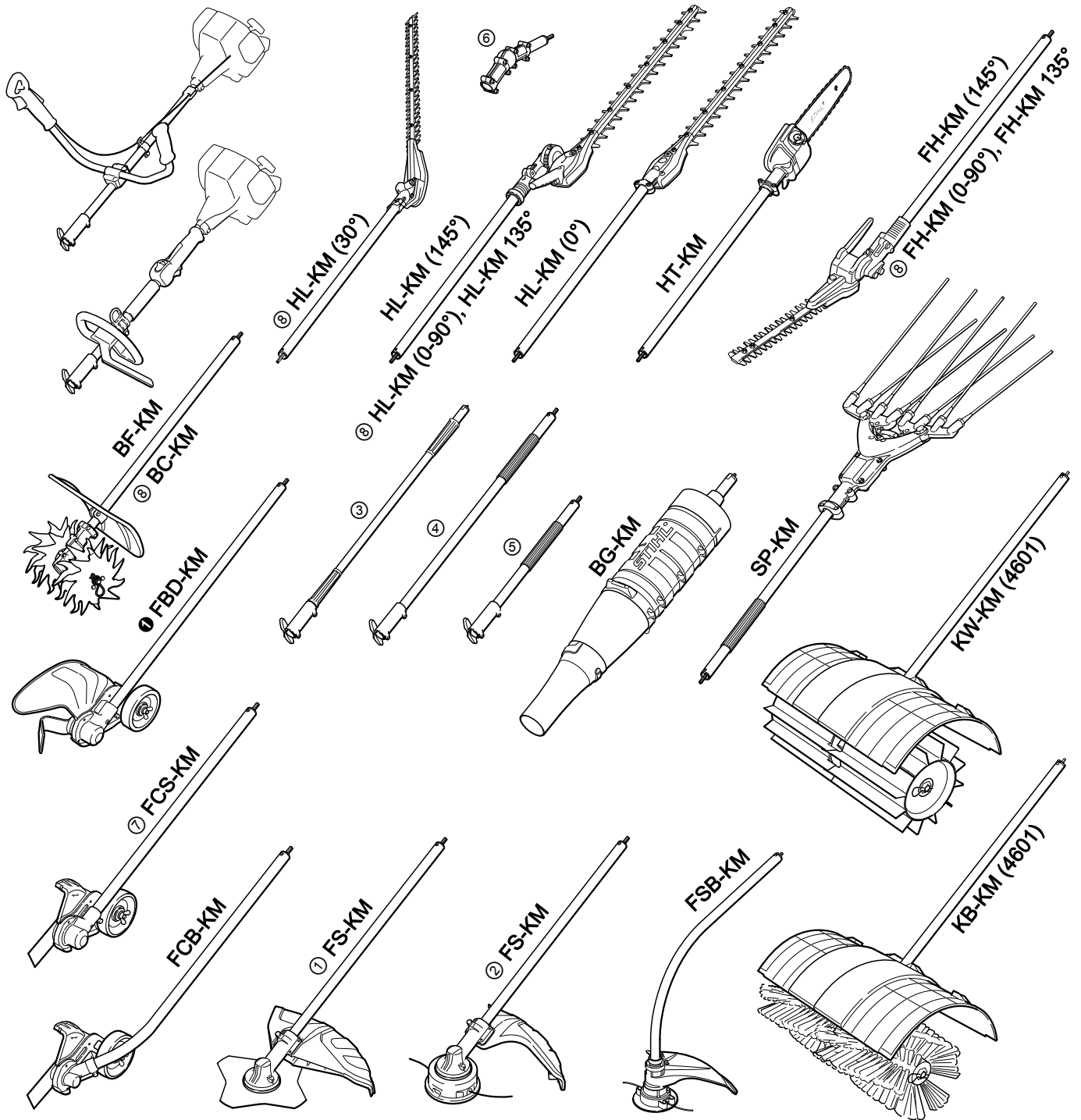
STIHL KombiVærktøjer

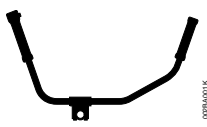

STIHL KombiVærktøjer

Tidligere betegnelse STIHL KombiVærktøj (C)					BC- KM				FH- KM 0..90° 135°		HL- KM 30° 0-90° 135°			KW- KM (4602)			
STIHL KombiVærktøj		FS- KM ①	FS- KM ②	FSB- KM	BF- KM	BG- KM	FCB- KM	FCS- KM	FH- KM 145°	HL- KM 0°	HL- KM 145°	HT- KM	KB- KM	KW- KM (4601)	SP- KM	FBD- KM	
● = tilladt ○ = kun betinget ergonomisk egnet — = ikke tilladt																	
KM 55		●	●	○	●	○	○	○	—	●	○	—	—	—	—	—	
KM 56		●	●	○	●	○	○	○	—	●	○	—	—	—	—	—	
KM 85		●	●	○	●	○	○	○	—	●	○	—	—	—	—	—	
KM 90		●	●	○	●	○	○	○	—	●	○	—	—	—	—	—	
KM 100		●	●	○	●	○	○	○	—	●	○	—	—	—	—	—	
KM 110		●	●	○	●	○	○	○	—	●	○	—	—	—	—	—	
KM 130		●	●	—	●	○	○	○	—	●	○	—	—	—	—	—	
KM 131		●	●	—	●	○	○	○	—	●	○	—	—	—	—	—	
KM 55 R		●	●	●	●	●	●	●	●	●	●	●	●	●	●	—	
KM 56 R		●	●	●	●	●	●	●	●	●	●	●	●	●	●	●	—
KM 85 R		●	●	●	●	●	●	●	●	●	●	●	●	●	●	●	—
KM 90 R		●	●	●	●	●	●	●	●	●	●	●	●	●	●	●	●
KM 91 R		●	●	●	●	●	●	●	●	●	●	●	●	●	●	●	●
KM 94 R		●	●	●	●	●	●	●	●	●	●	●	●	●	●	●	●
KM 100 R		●	●	●	●	●	●	●	●	●	●	●	●	●	●	●	●
KM 110 R		●	●	●	●	●	●	●	●	●	●	●	●	●	●	●	●
KM 111 R		●	●	●	●	●	●	●	●	●	●	●	●	●	●	●	●
KM 130 R		●	●	—	●	●	●	●	●	●	●	●	●	●	●	—	⑩
KM 131 R		●	●	—	●	●	●	●	●	●	●	●	●	●	●	—	●
KMA 130 R		●	●	—	●	●	●	●	●	●	●	●	●	●	●	●	●

① med græskniv eller kratkniv

② med trimmerhoved

③ skaffforlængelse (karbonfiber, 1 m): tilladt til HT-KM og HL-KM

④ skaffforlængelse (stål, 1 m): tilladt til HT-KM

⑤ skaffforlængelse (stål, 0,5 m): tilladt til HT-KM, HL-KM og SP-KM

⑥ vinkeldrev: tilladt til HT-KM og HL-KM 0°

⑦ kun FCS-KM med fleksibel drivaksel er tilladt til KM 130 R med papirlufffilter med et nedreguleringsomdrejningstal på 9500 o/min

⑧ leveres ikke længere

⑨ tidligere salgsbetegnelse

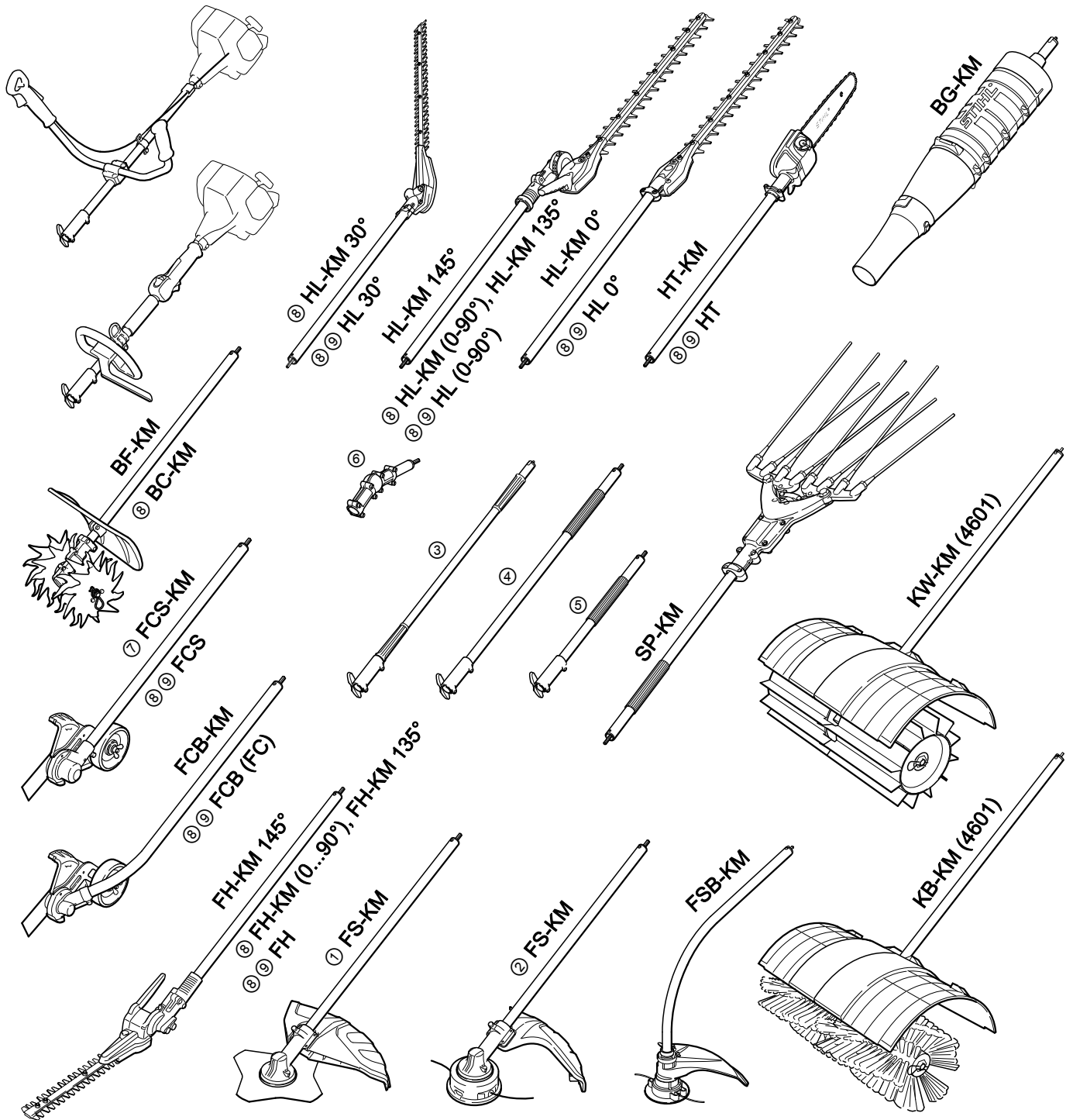

⑩ FBD-KM er kun tilladt til KM 130 R med papirlufffilter og et nedreguleringsomdrejningstal på 9500 o/min

KombiVærktøjer til redskaber med deleligt skaft



0000-GXX-3865-A0

KombiVærktøjer til redskaber med deleligt skaft

Tidligere betegnelse: STIHL påbygning (C)							FCS	(FC) FCB	FH	HL 0°	HL 30° 0..90°	HT		KW- (4602)	
Tidligere betegnelse: STIHL KombiVærktøj (C)				BC- KM					FH- KM 0..90° 135°		HL- KM 30° 0..90° 135°			KW- KM (4602)	
STIHL KombiVærktøj		FS- KM ①	FS- KM ②	FSB- KM	BF- KM	BG- KM	FCS- KM	FCB- KM	FH- KM 145°	HL- KM 0°	HL- KM 145°	HT- KM	KB- KM	KW- KM (4601)	SP- KM
● = tilladt ○ = kun betinget ergonomisk egnet — = ikke tilladt															
FS 55 T		●	●	○	●	○	○	○	●	—	○	—	—	—	—
FS 85 T		●	●	○	●	○	○	○	●	—	○	—	—	—	—
FS 55 RT		—	●	●	—	●	●	●	—	●	—	●	●	●	●
FS 85 RT		—	●	●	—	●	●	●	—	●	—	●	●	●	●
FR 85 RT		—	●	●	—	●	●	●	—	○	—	●	—	—	—
FR 130 T		—	●	●	●	●	●	●	●	○	●	●	—	—	—
FS 55 RT		●	●	●	●	●	●	●	●	●	●	●	●	●	●
FS 85 RT		●	●	●	●	●	●	●	●	●	●	●	●	●	●
FR 85 RT		●	●	●	●	●	●	●	●	●	○	●	●	—	—
FR 130 T		●	●	●	●	●	●	●	●	●	○	●	●	—	—
FR 131 T		●	●	●	●	●	●	●	●	○	●	●	—	—	—

① med græskniv eller kratkniv

② med trimmerhoved

③ skaftforlængelse (karbonfiber, 1 m): tilladt til HT-KM og HL-KM

③ skaftforlængelse (stål, 1 m): tilladt til HT-KM

③ skaftforlængelse (stål, 0,5 m): tilladt til HT-KM, HL-KM og SP-KM

⑥ vinkeldrev: tilladt til HT-KM og HL-KM 0°

⑦ kun FCS-KM med fleksibel drivaksel er tilladt til KM 130 R med papirlufffilter med et nedreguleringsomdrejningstal på 9500 o/min

⑧ leveres ikke længere

⑨ tidligere salgsbetegnelse

Påbygningsværktøj til STIHL-redskaber

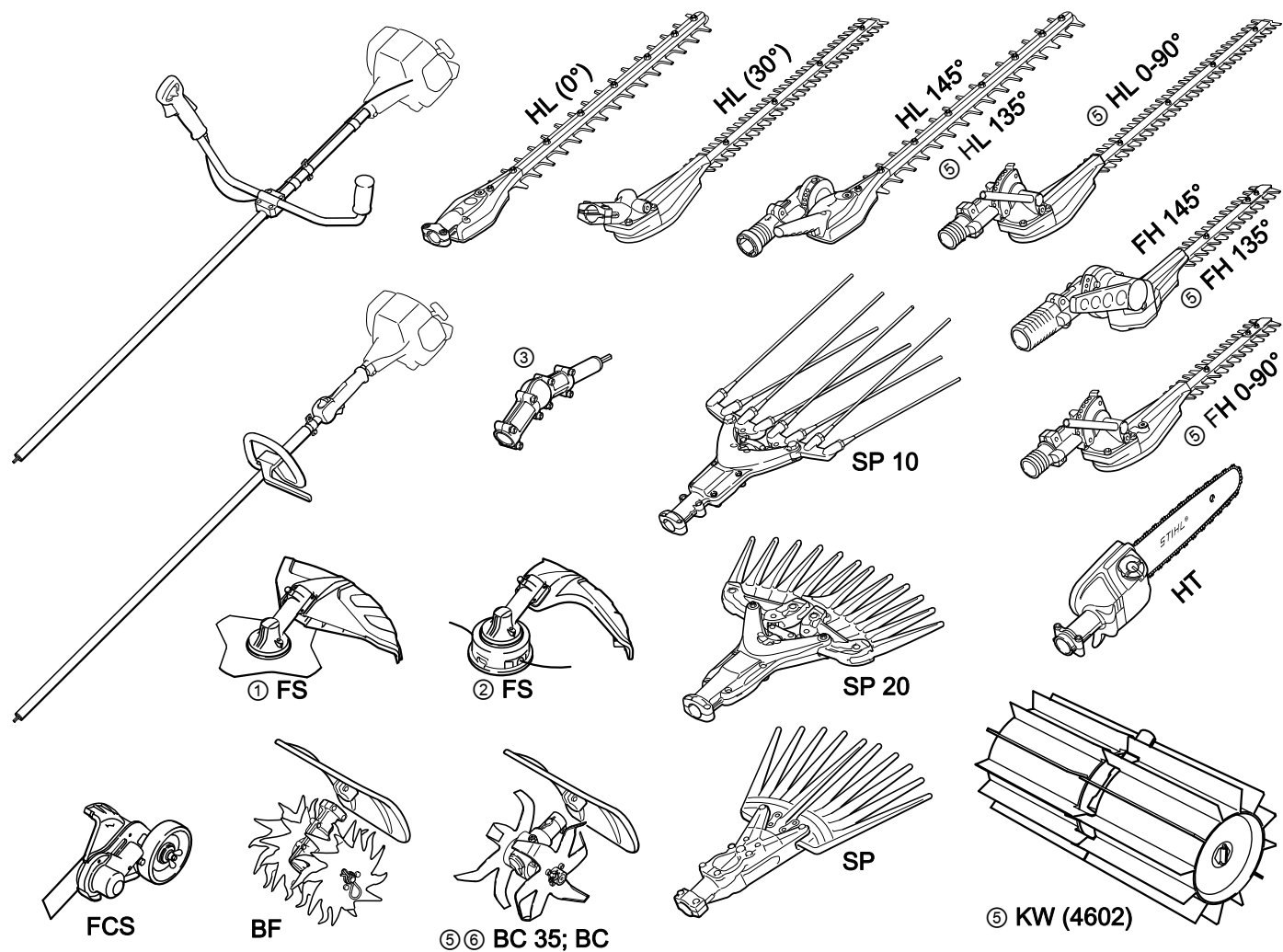

0000-GXX-3867-A0

Tidligere betegnelse: Påbygning (C)	BC 35 (BC)		FH 0-90° 135°	HL 0°	HL 30°	HL 0-90° 135°				KW (4602)			
STIHL påbygningsværktøj ● = tilladt ○ = kun betinget ergonomisk egnet — = ikke tilladt	BF	FCS	FH 145°	HL 0°		HL 145°	FS ①	FS ②	HT		SP	SP 10	SP 20
FS 85 ④	●	○	●	—	○	○	●	●	—	—	—	—	—
FS 90	●	○	●	—	○	○	●	●	—	—	—	—	—
FS 91	●	○	●	—	○	○	●	●	—	—	—	—	—
FS 100, 110	●	○	●	—	○	○	●	●	—	—	—	—	—
FS 111	●	○	●	—	○	○	●	●	—	—	—	—	—
FS 120, 200	●	—	—	—	—	—	●	●	—	—	—	—	—
FS 130	●	—	—	—	—	—	●	●	—	—	—	—	—
FS 131	●	—	—	—	—	—	●	●	—	—	—	—	—
FS 240, 250	●	—	—	—	—	—	●	●	—	—	—	—	—
KA 120	●	—	—	—	—	—	—	●	—	—	—	—	—



Påbygningsværktøj til STIHL-redskaber

Tidligere betegnelse: Påbygning (C)		BC 35 (BC)		FH 0-90° 135°	HL 0°	HL 30°	HL 0-90° 135°				KW (4602)				
STIHL påbygningsværktøj ● = tilladt ○ = kun betinget ergonomisk egnet — = ikke tilladt		BF	FCS	FH 145°	HL 0°		HL 145°	FS ①	FS ②	HT		SP	SP 10	SP 20	
FC 95, 110		●	●	●	●	●	●	●	●	●	●	●	●	—	
FC 111		●	●	●	●	●	●	●	●	●	●	●	●	—	
FH 75		●	—	●	●	●	●	—	—	—	●	①	●	—	
FR 85		●	●	●	●	●	●	●	●	●	●	—	①	●	—
FR 350, 410, 450		●	—	—	—	—	—	—	●	●	—	—	—	—	—
FR 460, 480		●	—	—	—	—	—	—	●	●	—	—	—	—	—
FS 85 R		●	●	●	●	●	●	●	●	●	●	●	①	●	—
FS 90 R		●	●	●	●	●	●	●	●	●	●	●	●	●	●
FS 91 R		●	●	●	●	●	●	●	●	●	●	●	●	●	●
FS 100 R, 110 R		②	②	②	②	②	②	②	②	②	②	②	②	②	②
FS 111 R		③	③	③	③	③	③	③	③	③	③	③	③	③	③
FS 120 R, 200 R		●	—	—	—	—	—	—	●	●	—	—	—	—	—
FS 130 R		●	—	—	—	—	—	●	●	●	●	—	●	—	—
FS 131 R		●	—	—	—	—	—	●	●	●	●	—	●	—	—
FS 240 R, 250 R		●	—	—	—	—	—	—	●	●	—	—	—	—	—
FT 100		—	—	—	—	—	—	—	—	—	●	—	—	—	—
HL 75		●	●	●	●	●	●	●	—	—	●	●	①	●	—
HL 75 K		—	—	—	—	●	●	●	—	—	—	—	①	●	—
HL 95, 100		●	●	●	●	●	●	●	—	—	●	●	●	●	—
HL 95 K, 100 K		—	—	—	—	●	●	●	—	—	—	—	●	●	—
KA 85 R		●	●	●	●	●	●	●	●	●	●	●	①	●	●
KA 120 R		●	●	●	●	●	●	●	●	●	●	●	①	●	●
KR 85		●	●	●	●	●	●	●	●	●	●	—	①	●	—
KW 85		●	—	●	●	●	●	●	—	—	—	●	—	—	—
SP 81		●	—	●	●	●	●	●	—	●	—	●	●	●	—

Påbygningsværktøj til STIHL-redskaber

Tidligere betegnelse: Påbygning (C)		BC 35 (BC)		FH 0-90° 135°	HL (0°)	HL 30°	HL 0-90° 135°				KW (4602)				
STIHL påbygningsværktøj ● = tilladt ○ = kun betinget ergonomisk egnet — = ikke tilladt		BF	FCS	FH 145°	HL 0°		HL 145°	FS ①	FS ②	HT		SP	SP 10	SP 20	
FC 95, 110	 002BA/02 K	●	●	●	●	●	●	—	●	●	●	●	●	—	
FC 111		●	●	●	●	●	●	—	●	●	●	●	●	—	
FH 75		●	—	●	●	●	●	—	—	—	—	●	①	●	—
FR 85		●	●	●	●	●	●	—	●	●	●	—	●	●	—
FR 350, 410, 450		●	—	—	—	—	—	—	●	—	—	—	—	—	—
FR 460, 480		●	—	—	—	—	—	—	●	—	—	—	—	—	—
FS 85 R		●	●	●	●	●	●	—	●	●	●	●	①	●	—
FS 90 R		●	●	●	●	●	●	—	●	●	●	●	①	●	●
FS 91 R		●	●	●	●	●	●	—	●	●	●	●	①	●	●
FS 100 R, 110 R		②	②	②	②	②	②	—	②	②	②	②	②	②	●
FS 111 R		②	②	②	②	②	②	—	②	②	②	②	②	②	●
FS 120 R, 200 R		●	—	—	—	—	—	—	●	—	—	—	—	—	—
FS 130 R		●	—	—	—	—	—	●	—	●	●	—	●	—	●
FS 131 R		●	—	—	—	—	—	●	—	●	●	—	●	—	●
FS 240 R, 250 R		●	—	—	—	—	—	—	●	—	—	—	—	—	—
FT 100		—	—	—	—	—	—	—	—	—	●	—	—	—	—
HL 75		●	●	●	●	●	●	—	—	●	●	●	①	●	—
HL 75 K		—	—	—	●	●	●	—	—	—	—	—	①	●	—
HL 91 K		●	—	—	●	—	●	—	—	●	—	—	—	●	—
HL 92		●	—	—	●	—	●	—	—	●	—	—	—	—	—
HL 94		●	—	—	●	—	●	—	—	●	—	—	—	—	—
HL 95, 100		●	●	●	●	●	●	—	—	●	●	●	●	●	—
HL 95 K, 100 K		—	—	—	●	●	●	—	—	—	—	—	●	●	—
KA 85 R		●	●	●	●	●	●	—	●	●	●	●	①	●	●
KR 85		●	●	●	●	●	●	—	●	●	—	—	①	●	—
KW 85		●	—	●	●	●	●	—	—	—	—	●	①	●	—
SP 81	●	—	●	●	●	●	—	●	—	—	●	●	●	—	

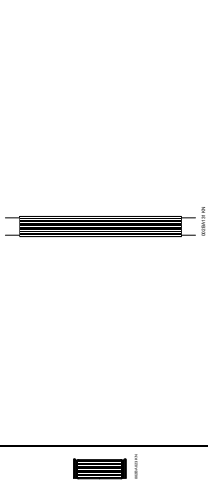
Påbygningsværktøj til STIHL-redskaber

Tidligere betegnelse: Påbygning (C)		BC 35 (BC)		FH 0-90° 135°	HL 0°	HL 30°	HL 0-90° 135°				KW (4602)				
STIHL påbygningsværktøj ● = tilladt ○ = kun betinget ergonomisk egnet — = ikke tilladt		BF	FCS	FH 145°	HL 0°		HL 145°	FS ①	FS ②	HT		SP	SP 10	SP 20	
HL 75		—	—	—	●	—	—	—	—	●	—	①	●	—	
HL 75 K		—	—	—	●	—	—	—	—	—	—	①	●	—	
HL 92 K		—	—	—	●	—	●	—	—	—	—	—	●	—	
HL 94 K		—	—	—	●	—	●	—	—	—	—	—	●	—	
HL 95, 100		—	—	—	●	—	—	—	—	—	●	—	●	—	
HL 95, 100 K		—	—	—	●	—	—	—	—	—	—	—	●	—	
HT 70		—	—	—	—	—	—	—	—	—	●	—	①	●	—
HT 75		—	—	—	—	●	—	—	—	—	●	—	—	—	—
HT 100		—	—	—	—	●	—	—	—	—	●	—	●	●	—
HT 130		—	—	—	—	②	—	—	—	—	●	—	●	—	—
HT 101, 131		—	—	—	—	—	—	—	—	—	●	—	—	—	—
SP 90		—	—	—	—	—	—	—	—	—	●	—	●	●	—
SP 92		—	—	—	—	—	—	—	—	—	—	—	●	●	●
SP 81			—	—	—	—	—	—	—	—	—	—	①	●	—

① med græskniv eller kratkniv

② med trimmerhoved

③ Vinkeldrev: kun tilladt til HT og HL 0°

④ ikke tilladt til FS 85 fra maskinnr. 1 49 709 301 til 1 53 148 868 og FS 85 RX

⑤ leveres ikke længere

⑥ tidligere salgsbetegnelse

⑦ kun tilladt fra maskinnr. 1 62 850 000, 2 63 970 000, 3 60 420 000

⑧ ikke tilladt til FS 100 RX, 110 RX

⑨ ikke tilladt til FS 111 RX

MultiVærktøj til STIHL MM 55, 56

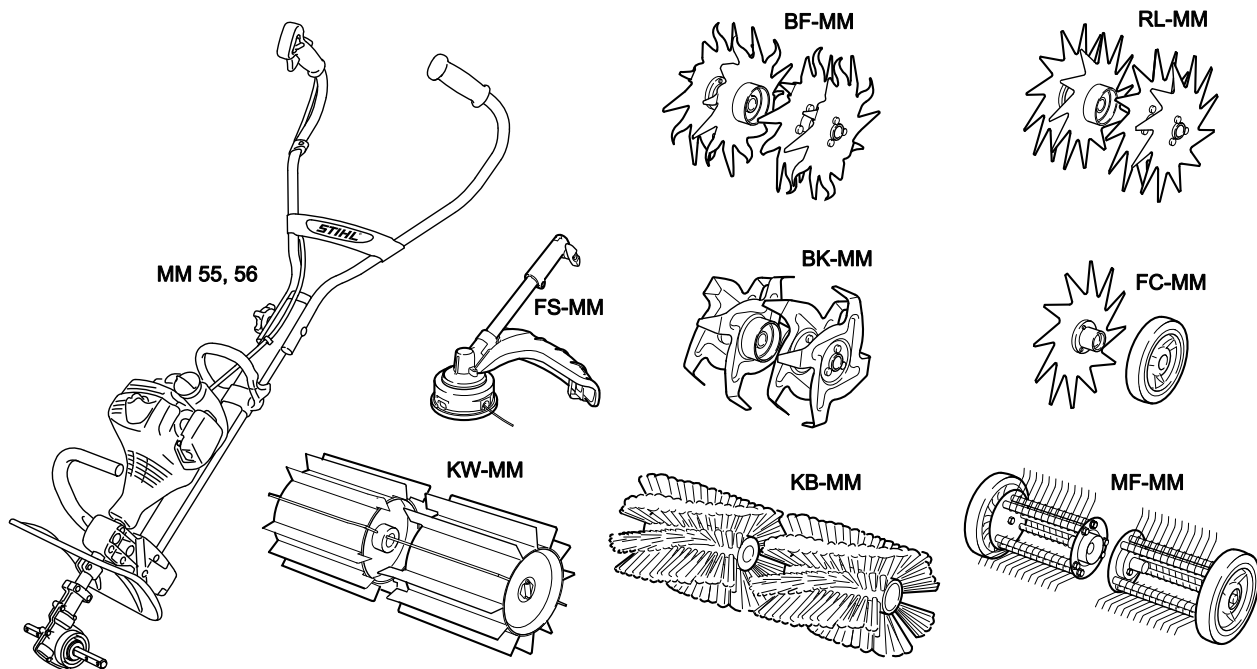

681KT882 KN

<ul style="list-style-type: none"> ● = tilladt ○ = kun betinget ergonomisk egnet — = ikke tilladt 		BF-MM	BK-MM	FC-MM	FS-MM	MF-MM	RL-MM	KB-MM	KW-MM
Drevplacering afhængig af MultiVærktøj		●	●	●	—	●	●	—	—
		—	—	—	—	—	—	●	●
		—	—	—	●	—	—	—	—

MultiVærktøj til STIHL MM 55, 56

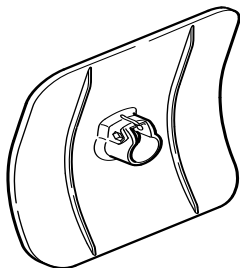
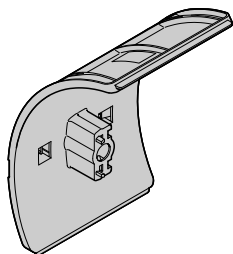
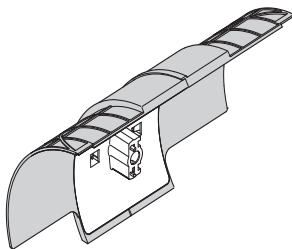
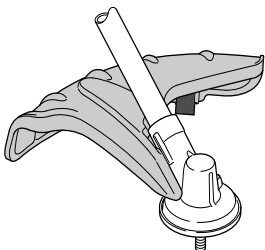
		BF-MM	BK-MM	FC-MM	FS-MM	MF-MM	RL-MM	KB-MM	KW-MM
<ul style="list-style-type: none"> ● = tilladt ○ = kun betinget ergonomisk egnet — = ikke tilladt 									
Anvendelse af beskyttelsen afhænger af MultiVærktøj	 4601 713 4500	●	●	●	—	—	●	—	●
	 4601 710 8100	●	●	●	—	—	●	—	●
	 4601 007 1009	—	—	—	—	●	—	●	●
	 4144 710 8117	—	—	—	●	—	—	—	—
	681KT438 KN								
	681KT883 KN								

Tegnforklaring:

- = deri indeholdt billednr.
- = tilladt
- (•) = kun tilladt til specialhåndtag med bøjle
- = ikke tilladt
- (A) = uden illustration
- (B) = kun specialtilbehør
- (C) = leveres ikke længere fra fabrikken
- (D) = enkeltvis ingen reservedel
- Ø = diameter

dänisch/dansk

0456 681 0801.VA4.A19

Trykt på klorfrit bleget papir